



Addendum No. 2
Page 1 of 1

DATE: April 21, 2016

Joliet Junior College
1215 Houbolt Road
Joliet, IL 60431

TO: Prospective Bidders
SUBJECT: Addendum No. 2
PROJECT NAME: City Center Campus Audio Visual Equipment
JJC PROJECT NO.: B16016

This Addendum forms a part of the Bidding and Contract Documents and modifies the original bidding document as posted on the JJC website. Acknowledge receipt of this addendum in the space provided on the Bid Form. FAILURE TO DO SO MAY SUBJECT BIDDER TO DISQUALIFICATION.

Clarifications/Modifications to bid documents:

1. Revised bid specifications have been included in this addendum. The originally posted bid specifications have been removed from the website to avoid confusion.
2. Revised bid drawings have been included in this addendum. The originally posted bid drawings have been removed from the website to avoid confusion.

End of addendum #2

PROJECT MANUAL

Date: April 21, 2016
Project No.: 13-016

CITY CENTER CAMPUS Integrated Audio-Video Systems

for

Joliet Junior College

1215 Houbolt Road
Joliet, Illinois 60431



DEMONICA KEMPER ARCHITECTS

125 N. Halsted Street, Suite 301
Chicago, Illinois 60661
Phone: 312.496.0000

DIVISION 1 - GENERAL REQUIREMENTS

01 10 00 Summary.....	3
01 26 00 Contract Modification Procedures.....	3
01 29 00 Payment Procedures	3
01 31 00 Project Management and Coordination	4
01 33 00 Submittal Procedures.....	5
01 42 00 References.....	2
01 60 00 Product Requirements	4
01 77 00 Closeout Procedures	3
01 78 23 Operation and Maintenance Data.....	3

DIVISION 27 - COMMUNICATIONS

27 41 16 Integrated Audio-Video Systems	54
----------	--	----

SECTION 01 10 00 - SUMMARY

PART 1 - GENERAL

1.1 RELATED DOCUMENTS

- A. Drawings and general provisions of the Contract, including General and Supplementary Conditions and other Division 01 Specification Sections, apply to this Section.

1.2 SUMMARY

- A. Section Includes:
 - 1. Work covered by Contract Documents.
 - 2. Work under separate contracts.
 - 3. Specification and drawing conventions.

1.3 WORK COVERED BY CONTRACT DOCUMENTS

- A. The Work of Project is defined by the Contract Documents and consists of the following:
 - 1. Bid scope includes the furnishing (including, but not limited to: purchase, storage, and delivery) and installation of Integrated Audio-Video Systems as noted on the Drawings and Specifications.

1.4 WORK UNDER SEPARATE CONTRACTS

- A. General: Cooperate fully with separate contractors so work on those contracts may be carried out smoothly, without interfering with or delaying work under this Contract or other contracts. Coordinate the Work of this Contract with work performed under separate contracts.
- B. Preceding Work: Owner has awarded separate contract(s) for the following construction operations at Project site. Those operations are scheduled to be substantially complete before work under this Contract begins.
 - 1. Interior Build-Out; a project completed through the Capital Development Board and awarded as multiple prime contracts for the following: General Construction, Electrical, Plumbing, Ventilation, Heating, Sprinkler.

1.5 ACCESS TO SITE

- A. General: Contractor shall have full use of Project site for construction operations during construction period. Contractor's use of Project site is limited only by Owner's right to perform work or to retain other contractors on portions of Project.

- B. Condition of Existing Building: Maintain portions of existing building affected by construction operations in a weathertight condition throughout construction period. Repair damage caused by construction operations.

1.6 COORDINATION WITH OCCUPANTS

- A. Owner Limited Occupancy of Completed Areas of Construction: Owner reserves the right to occupy and to place and install equipment in completed portions of the Work, prior to Substantial Completion of the Work, provided such occupancy does not interfere with completion of the Work. Such placement of equipment and limited occupancy shall not constitute acceptance of the total Work.
 - 1. Architect will prepare a Certificate of Substantial Completion for each specific portion of the Work to be occupied prior to Owner acceptance of the completed Work.
 - 2. Obtain a Certificate of Occupancy from authorities having jurisdiction before limited Owner occupancy.
 - 3. Before limited Owner occupancy, mechanical and electrical systems shall be fully operational, and required tests and inspections shall be successfully completed. On occupancy, Owner will operate and maintain mechanical and electrical systems serving occupied portions of Work.
 - 4. On occupancy, Owner will assume responsibility for maintenance and custodial service for occupied portions of Work.

1.7 WORK RESTRICTIONS

- A. Work Restrictions, General: Comply with restrictions on construction operations.
 - 1. Comply with limitations on use of public streets and with other requirements of authorities having jurisdiction.
- B. Nonsmoking Building: Smoking is not permitted within the building or within 25 feet of entrances, operable windows, or outdoor-air intakes.
- C. Controlled Substances: Use of tobacco products and other controlled substances on Project site is not permitted.

1.8 SPECIFICATION AND DRAWING CONVENTIONS

- A. Specification Content: The Specifications use certain conventions for the style of language and the intended meaning of certain terms, words, and phrases when used in particular situations. These conventions are as follows:
 - 1. Imperative mood and streamlined language are generally used in the Specifications. The words "shall," "shall be," or "shall comply with," depending on the context, are implied where a colon (:) is used within a sentence or phrase.
 - 2. Specification requirements are to be performed by Contractor unless specifically stated otherwise.
- B. Division 01 General Requirements: Requirements of Sections in Division 01 apply to the Work of all Sections in the Specifications.

- C. Drawing Coordination: Requirements for materials and products identified on Drawings are described in detail in the Specifications. One or more of the following are used on Drawings to identify materials and products:
1. Terminology: Materials and products are identified by the typical generic terms used in the individual Specifications Sections.
 2. Abbreviations: Materials and products are identified by abbreviations published as part of the U.S. National CAD Standard and scheduled on Drawings.
 3. Keynoting: Materials and products are identified by reference keynotes referencing Specification Section numbers found in this Project Manual.

PART 2 - PRODUCTS (Not Used)

PART 3 - EXECUTION (Not Used)

END OF SECTION 01 10 00

SECTION 01 26 00 - CONTRACT MODIFICATION PROCEDURES

PART 1 - GENERAL

1.1 RELATED DOCUMENTS

- A. Drawings and general provisions of the Contract, including General and Supplementary Conditions and other Division 01 Specification Sections, apply to this Section.

1.2 SUMMARY

- A. Section includes administrative and procedural requirements for handling and processing Contract modifications.
- B. Related Requirements:
 - 1. Section 01 25 00 "Substitution Procedures" for administrative procedures for handling requests for substitutions made after the Contract award.

1.3 MINOR CHANGES IN THE WORK

- A. Architect will issue supplemental instructions authorizing minor changes in the Work, not involving adjustment to the Contract Sum or the Contract Time, on AIA Document G710, "Architect's Supplemental Instructions."

1.4 PROPOSAL REQUESTS

- A. Owner-Initiated Proposal Requests: Architect will issue a detailed description of proposed changes in the Work that may require adjustment to the Contract Sum or the Contract Time. If necessary, the description will include supplemental or revised Drawings and Specifications.
 - 1. Work Change Proposal Requests issued by Architect are not instructions either to stop work in progress or to execute the proposed change.
 - 2. Within time specified in Proposal Request or 20 days, when not otherwise specified, after receipt of Proposal Request, submit a quotation estimating cost adjustments to the Contract Sum and the Contract Time necessary to execute the change.
 - a. Include a list of quantities of products required or eliminated and unit costs, with total amount of purchases and credits to be made. If requested, furnish survey data to substantiate quantities.
 - b. Indicate applicable taxes, delivery charges, equipment rental, and amounts of trade discounts.
 - c. Include costs of labor and supervision directly attributable to the change.
 - d. Include an updated Contractor's construction schedule that indicates the effect of the change, including, but not limited to, changes in activity duration, start and finish times, and activity relationship. Use available total float before requesting an extension of the Contract Time.

- e. Quotation Form: Use CSI Form 13.6D, "Proposal Worksheet Summary," and Form 13.6C, "Proposal Worksheet Detail."
- B. Contractor-Initiated Proposals: If latent or changed conditions require modifications to the Contract, Contractor may initiate a claim by submitting a request for a change to Architect.
- 1. Include a statement outlining reasons for the change and the effect of the change on the Work. Provide a complete description of the proposed change. Indicate the effect of the proposed change on the Contract Sum and the Contract Time.
 - 2. Include a list of quantities of products required or eliminated and unit costs, with total amount of purchases and credits to be made. If requested, furnish survey data to substantiate quantities.
 - 3. Indicate applicable taxes, delivery charges, equipment rental, and amounts of trade discounts.
 - 4. Include costs of labor and supervision directly attributable to the change.
 - 5. Include an updated Contractor's construction schedule that indicates the effect of the change, including, but not limited to, changes in activity duration, start and finish times, and activity relationship. Use available total float before requesting an extension of the Contract Time.
 - 6. Comply with requirements in Section 01 25 00 "Substitution Procedures" if the proposed change requires substitution of one product or system for product or system specified.
 - 7. Proposal Request Form: Use CSI Form 13.6A, "Change Order Request (Proposal)," with attachments CSI Form 13.6D, "Proposal Worksheet Summary," and Form 13.6C, "Proposal Worksheet Detail."

1.5 CHANGE ORDER PROCEDURES

- A. On Owner's approval of a Work Changes Proposal Request, Architect will issue a Change Order for signatures of Owner and Contractor on AIA Document G701 .

1.6 CONSTRUCTION CHANGE DIRECTIVE

- A. Construction Change Directive: Architect may issue a Construction Change Directive on AIA Document G714 . Construction Change Directive instructs Contractor to proceed with a change in the Work, for subsequent inclusion in a Change Order.
 - 1. Change Directive contains a complete description of change in the Work. It also designates method to be followed to determine change in the Contract Sum or the Contract Time.
- B. Documentation: Maintain detailed records on a time and material basis of work required by the Construction Change Directive.
 - 1. After completion of change, submit an itemized account and supporting data necessary to substantiate cost and time adjustments to the Contract.

PART 2 - PRODUCTS (Not Used)

PART 3 - EXECUTION (Not Used)

END OF SECTION 01 26 00

SECTION 01 29 00 - PAYMENT PROCEDURES

PART 1 - GENERAL

1.1 RELATED DOCUMENTS

- A. Drawings and general provisions of the Contract, including General and Supplementary Conditions and other Division 01 Specification Sections, apply to this Section.

1.2 SUMMARY

- A. Section includes administrative and procedural requirements necessary to prepare and process Applications for Payment.
- B. Related Requirements:
 - 1. Section 01 26 00 "Contract Modification Procedures" for administrative procedures for handling changes to the Contract.

1.3 DEFINITIONS

- A. Schedule of Values: A statement furnished by Contractor allocating portions of the Contract Sum to various portions of the Work and used as the basis for reviewing Contractor's Applications for Payment.

1.4 APPLICATIONS FOR PAYMENT

- A. Each Application for Payment following the initial Application for Payment shall be consistent with previous applications and payments as certified by Architect and paid for by Owner.
 - 1. Initial Application for Payment, Application for Payment at time of Substantial Completion, and final Application for Payment involve additional requirements.
- B. Payment Application Times: Submit Application for Payment to Architect by the 21st day of the month. The period covered by each Application for Payment is one month, ending on the last day of the month.
 - 1. Submit draft copy of Application for Payment seven days prior to due date for review by Architect.
- C. Application for Payment Forms: Use forms acceptable to Architect and Owner for Applications for Payment. Submit forms for approval with initial submittal of schedule of values.
- D. Application Preparation: Complete every entry on form. Notarize and execute by a person authorized to sign legal documents on behalf of Contractor. Architect will return incomplete applications without action.

1. Entries shall match data on the schedule of values and Contractor's construction schedule. Use updated schedules if revisions were made.
 2. Include amounts for work completed following previous Application for Payment, whether or not payment has been received. Include only amounts for work completed at time of Application for Payment.
 3. Include amounts of Change Orders and Construction Change Directives issued before last day of construction period covered by application.
 4. Indicate separate amounts for work being carried out under Owner-requested project acceleration.
- E. Stored Materials: Include in Application for Payment amounts applied for materials or equipment purchased or fabricated and stored, but not yet installed. Differentiate between items stored on-site and items stored off-site.
1. Provide certificate of insurance, evidence of transfer of title to Owner, and consent of surety to payment, for stored materials.
 2. Provide supporting documentation that verifies amount requested, such as paid invoices. Match amount requested with amounts indicated on documentation; do not include overhead and profit on stored materials.
 3. Provide summary documentation for stored materials indicating the following:
 - a. Value of materials previously stored and remaining stored as of date of previous Applications for Payment.
 - b. Value of previously stored materials put in place after date of previous Application for Payment and on or before date of current Application for Payment.
 - c. Value of materials stored since date of previous Application for Payment and remaining stored as of date of current Application for Payment.
- F. Waivers of Mechanic's Lien: With each Application for Payment, submit waivers of mechanic's liens from subcontractors, sub-subcontractors, and suppliers for construction period covered by the previous application.
1. Submit partial waivers on each item for amount requested in previous application, after deduction for retainage, on each item.
 2. When an application shows completion of an item, submit conditional final or full waivers.
 3. Owner reserves the right to designate which entities involved in the Work must submit waivers.
 4. Submit final Application for Payment with or preceded by conditional final waivers from every entity involved with performance of the Work covered by the application who is lawfully entitled to a lien.
 5. Waiver Forms: Submit executed waivers of lien on forms, acceptable to Owner.
- G. Initial Application for Payment: Administrative actions and submittals that must precede or coincide with submittal of first Application for Payment include the following:
1. List of subcontractors.
 2. Schedule of values.
 3. Contractor's construction schedule (preliminary if not final).
 4. Products list (preliminary if not final).
 5. Submittal schedule (preliminary if not final).
 6. Certificates of insurance and insurance policies.
 7. Performance and payment bonds.

8. Data needed to acquire Owner's insurance.
- H. Application for Payment at Substantial Completion: After Architect issues the Certificate of Substantial Completion, submit an Application for Payment showing 100 percent completion for portion of the Work claimed as substantially complete.
1. Include documentation supporting claim that the Work is substantially complete and a statement showing an accounting of changes to the Contract Sum.
 2. This application shall reflect Certificate(s) of Substantial Completion issued previously for Owner occupancy of designated portions of the Work.
- I. Final Payment Application: After completing Project closeout requirements, submit final Application for Payment with releases and supporting documentation not previously submitted and accepted, including, but not limited, to the following:
1. Evidence of completion of Project closeout requirements.
 2. Insurance certificates for products and completed operations where required and proof that taxes, fees, and similar obligations were paid.
 3. Updated final statement, accounting for final changes to the Contract Sum.
 4. AIA Document G706, "Contractor's Affidavit of Payment of Debts and Claims."
 5. AIA Document G706A, "Contractor's Affidavit of Release of Liens."
 6. AIA Document G707, "Consent of Surety to Final Payment."

PART 2 - PRODUCTS (Not Used)

PART 3 - EXECUTION (Not Used)

END OF SECTION 01 29 00

SECTION 01 31 00 - PROJECT MANAGEMENT AND COORDINATION

PART 1 - GENERAL

1.1 RELATED DOCUMENTS

- A. Drawings and general provisions of the Contract, including General and Supplementary Conditions and other Division 01 Specification Sections, apply to this Section.

1.2 SUMMARY

- A. Section includes administrative provisions for coordinating construction operations on Project including, but not limited to, the following:
 - 1. General coordination procedures.
 - 2. Requests for Information (RFIs).
- B. Related Requirements:
 - 1. Section 01 77 00 "Closeout Procedures" for coordinating closeout of the Contract.

1.3 DEFINITIONS

- A. RFI: Request from Owner, Architect, or Contractor seeking information required by or clarifications of the Contract Documents.

1.4 INFORMATIONAL SUBMITTALS

- A. Subcontract List: Prepare a written summary identifying individuals or firms proposed for each portion of the Work, including those who are to furnish products or equipment fabricated to a special design. Use CSI Form 1.5A. Include the following information in tabular form:
 - 1. Name, address, and telephone number of entity performing subcontract or supplying products.
 - 2. Number and title of related Specification Section(s) covered by subcontract.
 - 3. Drawing number and detail references, as appropriate, covered by subcontract.
- B. Key Personnel Names: Within 15 days of starting construction operations, submit a list of key personnel assignments, including superintendent and other personnel in attendance at Project site. Identify individuals and their duties and responsibilities; list addresses and telephone numbers, including home, office, and cellular telephone numbers and e-mail addresses. Provide names, addresses, and telephone numbers of individuals assigned as alternates in the absence of individuals assigned to Project.

1.5 GENERAL COORDINATION PROCEDURES

- A. Coordination: Coordinate construction operations included in different Sections of the Specifications to ensure efficient and orderly installation of each part of the Work. Coordinate construction operations, included in different Sections, that depend on each other for proper installation, connection, and operation.
 - 1. Schedule construction operations in sequence required to obtain the best results where installation of one part of the Work depends on installation of other components, before or after its own installation.
 - 2. Coordinate installation of different components to ensure maximum performance and accessibility for required maintenance, service, and repair.
 - 3. Make adequate provisions to accommodate items scheduled for later installation.
- B. Prepare memoranda for distribution to each party involved, outlining special procedures required for coordination. Include such items as required notices, reports, and list of attendees at meetings.
- C. Administrative Procedures: Coordinate scheduling and timing of required administrative procedures with other construction activities and activities of other contractors to avoid conflicts and to ensure orderly progress of the Work. Such administrative activities include, but are not limited to, the following:
 - 1. Preparation of Contractor's construction schedule.
 - 2. Preparation of the schedule of values.
 - 3. Delivery and processing of submittals.
 - 4. Progress meetings.
 - 5. Project closeout activities.

1.6 REQUESTS FOR INFORMATION (RFIs)

- A. General: Immediately on discovery of the need for additional information or interpretation of the Contract Documents, Contractor shall prepare and submit an RFI in the form specified.
 - 1. Architect will return RFIs submitted to Architect by other entities controlled by Contractor with no response.
 - 2. Coordinate and submit RFIs in a prompt manner so as to avoid delays in Contractor's work or work of subcontractors.
- B. Content of the RFI: Include a detailed, legible description of item needing information or interpretation and the following:
 - 1. Project name.
 - 2. Project number.
 - 3. Date.
 - 4. Name of Contractor.
 - 5. Name of Architect.
 - 6. RFI number, numbered sequentially.
 - 7. RFI subject.
 - 8. Specification Section number and title and related paragraphs, as appropriate.
 - 9. Drawing number and detail references, as appropriate.
 - 10. Field dimensions and conditions, as appropriate.

11. Contractor's suggested resolution. If Contractor's suggested resolution impacts the Contract Time or the Contract Sum, Contractor shall state impact in the RFI.
 12. Contractor's signature.
 13. Attachments: Include sketches, descriptions, measurements, photos, Product Data, Shop Drawings, coordination drawings, and other information necessary to fully describe items needing interpretation.
 - a. Include dimensions, thicknesses, structural grid references, and details of affected materials, assemblies, and attachments on attached sketches.
- C. RFI Forms: Software-generated form with substantially the same content as indicated above, acceptable to Architect.
1. Attachments shall be electronic files in Adobe Acrobat PDF format.
- D. Architect's Action: Architect will review each RFI, determine action required, and respond. Allow seven working days for Architect's response for each RFI. RFIs received by Architect after 1:00 p.m. will be considered as received the following working day.
1. The following Contractor-generated RFIs will be returned without action:
 - a. Requests for approval of submittals.
 - b. Requests for approval of substitutions.
 - c. Requests for approval of Contractor's means and methods.
 - d. Requests for coordination information already indicated in the Contract Documents.
 - e. Requests for adjustments in the Contract Time or the Contract Sum.
 - f. Requests for interpretation of Architect's actions on submittals.
 - g. Incomplete RFIs or inaccurately prepared RFIs.
 2. Architect's action may include a request for additional information, in which case Architect's time for response will date from time of receipt of additional information.
 3. Architect's action on RFIs that may result in a change to the Contract Time or the Contract Sum may be eligible for Contractor to submit Change Proposal according to Section 01 26 00 "Contract Modification Procedures."
 - a. If Contractor believes the RFI response warrants change in the Contract Time or the Contract Sum, notify Architect in writing within days of receipt of the RFI response.
- E. RFI Log: Prepare, maintain, and submit a tabular log of RFIs organized by the RFI number. Submit log weekly. Software log with not less than the following:
1. Project name.
 2. Name and address of Contractor.
 3. RFI number including RFIs that were returned without action or withdrawn.
 4. RFI description.
 5. Date the RFI was submitted.
 6. Date Architect's response was received.
- F. On receipt of Architect's action, update the RFI log and immediately distribute the RFI response to affected parties. Review response and notify Architect within seven days if

Contractor disagrees with response.

PART 2 - PRODUCTS (Not Used)

PART 3 - EXECUTION (Not Used)

END OF SECTION 01 31 00

SECTION 01 33 00 - SUBMITTAL PROCEDURES

PART 1 - GENERAL

1.1 RELATED DOCUMENTS

- A. Drawings and general provisions of the Contract, including General and Supplementary Conditions and other Division 01 Specification Sections, apply to this Section.

1.2 SUMMARY

- A. Section includes requirements for the submittal schedule and administrative and procedural requirements for submitting Shop Drawings, Product Data, Samples, and other submittals.
- B. Related Requirements:
 - 1. Section 01 29 00 "Payment Procedures" for submitting Applications for Payment and the schedule of values.
 - 2. Section 01 78 23 "Operation and Maintenance Data" for submitting operation and maintenance manuals.

1.3 DEFINITIONS

- A. Action Submittals: Written and graphic information and physical samples that require Architect's and Construction Manager's responsive action. Action submittals are those submittals indicated in individual Specification Sections as "action submittals."
- B. Informational Submittals: Written and graphic information and physical samples that do not require Architect's and Construction Manager's responsive action. Submittals may be rejected for not complying with requirements. Informational submittals are those submittals indicated in individual Specification Sections as "informational submittals."
- C. File Transfer Protocol (FTP): Communications protocol that enables transfer of files to and from another computer over a network and that serves as the basis for standard Internet protocols. An FTP site is a portion of a network located outside of network firewalls within which internal and external users are able to access files.
- D. Portable Document Format (PDF): An open standard file format licensed by Adobe Systems used for representing documents in a device-independent and display resolution-independent fixed-layout document format.

1.4 SUBMITTAL ADMINISTRATIVE REQUIREMENTS

- A. Architect's Digital Data Files: Electronic digital data files of the Contract Drawings will not be provided by Architect for Contractor's use in preparing submittals.
- B. Coordination: Coordinate preparation and processing of submittals with performance of construction activities.

1. Coordinate each submittal with fabrication, purchasing, testing, delivery, other submittals, and related activities that require sequential activity.
 2. Submit all submittal items required for each Specification Section concurrently unless partial submittals for portions of the Work are indicated on approved submittal schedule.
 3. Submit action submittals and informational submittals required by the same Specification Section as separate packages under separate transmittals.
 4. Coordinate transmittal of different types of submittals for related parts of the Work so processing will not be delayed because of need to review submittals concurrently for coordination.
 - a. Architect and Construction Manager reserve the right to withhold action on a submittal requiring coordination with other submittals until related submittals are received.
- C. Processing Time: Allow time for submittal review, including time for resubmittals, as follows. Time for review shall commence on Construction Manager's receipt of submittal. No extension of the Contract Time will be authorized because of failure to transmit submittals enough in advance of the Work to permit processing, including resubmittals.
1. Initial Review: Allow 15 days for initial review of each submittal. Allow additional time if coordination with subsequent submittals is required. Construction Manager will advise Contractor when a submittal being processed must be delayed for coordination.
 2. Intermediate Review: If intermediate submittal is necessary, process it in same manner as initial submittal.
 3. Resubmittal Review: Allow 15 days for review of each resubmittal.
 4. Concurrent Consultant Review: Where the Contract Documents indicate that submittals may be transmitted simultaneously to Architect and to Architect's consultants, allow 15 days for review of each submittal. Submittal will be returned to Construction Manager, through Architect, before being returned to Contractor.
- D. Electronic Submittals: Identify and incorporate information in each electronic submittal file as follows:
1. Assemble complete submittal package into a single indexed file incorporating submittal requirements of a single Specification Section and transmittal form with links enabling navigation to each item.
 2. Name file with submittal number or other unique identifier, including revision identifier.
 - a. File name shall use project identifier and Specification Section number followed by a decimal point and then a sequential number (e.g., LNHS-061000.01). Resubmittals shall include an alphabetic suffix after another decimal point (e.g., LNHS-061000.01.A).
 3. Provide means for insertion to permanently record Contractor's review and approval markings and action taken by Architect and Construction Manager.
 4. Transmittal Form for Electronic Submittals: Use electronic form acceptable to Owner, containing the following information:
 - a. Project name.
 - b. Date.
 - c. Name and address of Architect.

- d. Name of Construction Manager.
 - e. Name of Contractor.
 - f. Name of firm or entity that prepared submittal.
 - g. Names of subcontractor, manufacturer, and supplier.
 - h. Category and type of submittal.
 - i. Submittal purpose and description.
 - j. Specification Section number and title.
 - k. Specification paragraph number or drawing designation and generic name for each of multiple items.
 - l. Drawing number and detail references, as appropriate.
 - m. Location(s) where product is to be installed, as appropriate.
 - n. Related physical samples submitted directly.
 - o. Indication of full or partial submittal.
 - p. Transmittal number, numbered consecutively.
 - q. Submittal and transmittal distribution record.
 - r. Other necessary identification.
 - s. Remarks.
- E. Options: Identify options requiring selection by Architect.
- F. Deviations and Additional Information: On an attached separate sheet, prepared on Contractor's letterhead, record relevant information, requests for data, revisions other than those requested by Architect and Construction Manager on previous submittals, and deviations from requirements in the Contract Documents, including minor variations and limitations. Include same identification information as related submittal.
- G. Resubmittals: Make resubmittals in same form and number of copies as initial submittal.
- 1. Note date and content of previous submittal.
 - 2. Note date and content of revision in label or title block and clearly indicate extent of revision.
 - 3. Resubmit submittals until they are marked with approval notation from Architect's and Construction Manager's action stamp.
- H. Distribution: Furnish copies of final submittals to manufacturers, subcontractors, suppliers, fabricators, installers, authorities having jurisdiction, and others as necessary for performance of construction activities. Show distribution on transmittal forms.
- I. Use for Construction: Retain complete copies of submittals on Project site. Use only final action submittals that are marked with approval notation from Architect's and Construction Manager's action stamp.

PART 2 - PRODUCTS

2.1 SUBMITTAL PROCEDURES

- A. General Submittal Procedure Requirements: Prepare and submit submittals required by individual Specification Sections. Types of submittals are indicated in individual Specification Sections.
- 1. Submit electronic submittals via email as PDF electronic files.
 - a. Architect, through Construction Manager, will return annotated file.

Annotate and retain one copy of file as an electronic Project record document file.

- B. Product Data: Collect information into a single submittal for each element of construction and type of product or equipment.
1. If information must be specially prepared for submittal because standard published data are not suitable for use, submit as Shop Drawings, not as Product Data.
 2. Mark each copy of each submittal to show which products and options are applicable.
 3. Include the following information, as applicable:
 - a. Manufacturer's catalog cuts.
 - b. Manufacturer's product specifications.
 - c. Standard color charts.
 - d. Statement of compliance with specified referenced standards.
 - e. Application of testing agency labels and seals.
 - f. Notation of coordination requirements.
 - g. Availability and delivery time information.
 4. For equipment, include the following in addition to the above, as applicable:
 - a. Wiring diagrams showing factory-installed wiring.
 - b. Clearances required to other construction, if not indicated on accompanying Shop Drawings.
 5. Submit Product Data in the following format:
 - a. PDF electronic file.
- C. Shop Drawings: Prepare Project-specific information, drawn accurately to scale. Do not base Shop Drawings on reproductions of the Contract Documents or standard printed data.
1. Preparation: Fully illustrate requirements in the Contract Documents. Include the following information, as applicable:
 - a. Identification of products.
 - b. Schedules.
 - c. Compliance with specified standards.
 - d. Notation of coordination requirements.
 - e. Notation of dimensions established by field measurement.
 - f. Relationship and attachment to adjoining construction clearly indicated.
 - g. Seal and signature of professional engineer if specified.
 2. Sheet Size: Except for templates, patterns, and similar full-size drawings, submit Shop Drawings on sheets at least 8-1/2 by 11 inches, but no larger than 30 by 42 inches.
 3. Submit Shop Drawings in the following format:
 - a. PDF electronic file.
- D. Coordination Drawing Submittals: Comply with requirements specified in Section 01 31 00 "Project Management and Coordination."

- E. Application for Payment and Schedule of Values: Comply with requirements specified in Section 01 29 00 "Payment Procedures."
- F. Closeout Submittals and Maintenance Material Submittals: Comply with requirements specified in Section 01 77 00 "Closeout Procedures."
- G. Maintenance Data: Comply with requirements specified in Section 01 78 23 "Operation and Maintenance Data."

PART 3 - EXECUTION

3.1 CONTRACTOR'S REVIEW

- A. Action and Informational Submittals: Review each submittal and check for coordination with other Work of the Contract and for compliance with the Contract Documents. Note corrections and field dimensions. Mark with approval stamp before submitting to Architect and Construction Manager.
- B. Project Closeout and Maintenance Material Submittals: See requirements in Section 01 77 00 "Closeout Procedures."
- C. Approval Stamp: Stamp each submittal with a uniform, approval stamp. Include Project name and location, submittal number, Specification Section title and number, name of reviewer, date of Contractor's approval, and statement certifying that submittal has been reviewed, checked, and approved for compliance with the Contract Documents.

3.2 ARCHITECT'S AND CONSTRUCTION MANAGER'S ACTION

- A. Informational Submittals: Architect and Construction Manager will review each submittal and will not return it, or will return it if it does not comply with requirements. Architect and Construction Manager will forward each submittal to appropriate party.
- B. Partial submittals prepared for a portion of the Work will be reviewed when use of partial submittals has received prior approval from Architect and Construction Manager.
- C. Incomplete submittals are unacceptable, will be considered nonresponsive, and will be returned for resubmittal without review.
- D. Submittals not required by the Contract Documents may be returned by the Architect without action.

END OF SECTION 01 33 00

SECTION 01 42 00 - REFERENCES

PART 1 - GENERAL

1.1 RELATED DOCUMENTS

- A. Drawings and general provisions of the Contract, including General and Supplementary Conditions and other Division 01 Specification Sections, apply to this Section.

1.2 DEFINITIONS

- A. General: Basic Contract definitions are included in the Conditions of the Contract.
- B. "Approved": When used to convey Architect's action on Contractor's submittals, applications, and requests, "approved" is limited to Architect's duties and responsibilities as stated in the Conditions of the Contract.
- C. "Directed": A command or instruction by Architect. Other terms including "requested," "authorized," "selected," "required," and "permitted" have the same meaning as "directed."
- D. "Indicated": Requirements expressed by graphic representations or in written form on Drawings, in Specifications, and in other Contract Documents. Other terms including "shown," "noted," "scheduled," and "specified" have the same meaning as "indicated."
- E. "Regulations": Laws, ordinances, statutes, and lawful orders issued by authorities having jurisdiction, and rules, conventions, and agreements within the construction industry that control performance of the Work.
- F. Avoid revising "Furnish," "Install," and "Provide" paragraphs below because of widespread acceptance and understanding of these terms as defined.
- G. "Furnish": Supply and deliver to Project site, ready for unloading, unpacking, assembly, installation, and similar operations.
- H. "Install": Operations at Project site including unloading, temporarily storing, unpacking, assembling, erecting, placing, anchoring, applying, working to dimension, finishing, curing, protecting, cleaning, and similar operations.
- I. "Provide": Furnish and install, complete and ready for the intended use.
- J. Generally retain "Project Site" Paragraph below; revise to suit Project. See Evaluations.
- K. "Project Site": Space available for performing construction activities. The extent of Project site is shown on Drawings and may or may not be identical with the description of the land on which Project is to be built.

1.3 INDUSTRY STANDARDS

- A. Applicability of Standards: Unless the Contract Documents include more stringent requirements, applicable construction industry standards have the same force and effect

as if bound or copied directly into the Contract Documents to the extent referenced. Such standards are made a part of the Contract Documents by reference.

- B. Retain "Publication Dates" Paragraph below unless Specifications are revised to insert dates (which is not recommended). Unreferenced standards are not applicable. Revise effective date of the standard established below to suit Project.
- C. Publication Dates: Comply with standards in effect as of date of the Contract Documents unless otherwise indicated.
- D. Retain "Copies of Standards" Paragraph below on projects where copies of standards are needed. A requirement to retain many standards on a project site could become expensive. See Evaluations.
- E. Copies of Standards: Each entity engaged in construction on Project should be familiar with industry standards applicable to its construction activity. Copies of applicable standards are not bound with the Contract Documents.
 - 1. Where copies of standards are needed to perform a required construction activity, obtain copies directly from publication source.

1.4 ABBREVIATIONS AND ACRONYMS

- A. Industry Organizations: Where abbreviations and acronyms are used in Specifications or other Contract Documents, they shall mean the recognized name of the entities indicated in Thomson Gale's "Encyclopedia of Associations" or in Columbia Books' "National Trade & Professional Associations of the U.S."

PART 2 - PRODUCTS (Not Used)

PART 3 - EXECUTION (Not Used)

END OF SECTION 01 42 00

SECTION 01 60 00 - PRODUCT REQUIREMENTS

PART 1 - GENERAL

1.1 RELATED DOCUMENTS

- A. Drawings and general provisions of the Contract, including General and Supplementary Conditions and other Division 01 Specification Sections, apply to this Section.

1.2 SUMMARY

- A. Section includes administrative and procedural requirements for selection of products for use in Project; product delivery, storage, and handling; manufacturers' standard warranties on products; special warranties; and comparable products.
- B. Related Requirements:
 - 1. Section 01 25 00 "Substitution Procedures" for requests for substitutions.
 - 2. Section 01 42 00 "References" for applicable industry standards for products specified.

1.3 DEFINITIONS

- A. Products: Items obtained for incorporating into the Work, whether purchased for Project or taken from previously purchased stock. The term "product" includes the terms "material," "equipment," "system," and terms of similar intent.
 - 1. Named Products: Items identified by manufacturer's product name, including make or model number or other designation shown or listed in manufacturer's published product literature, that is current as of date of the Contract Documents.
 - 2. New Products: Items that have not previously been incorporated into another project or facility. Products salvaged or recycled from other projects are not considered new products.
 - 3. Comparable Product: Product that is demonstrated and approved through submittal process to have the indicated qualities related to type, function, dimension, in-service performance, physical properties, appearance, and other characteristics that equal or exceed those of specified product.

1.4 ACTION SUBMITTALS

- A. Comparable Product Requests: Submit request for consideration of each comparable product. Identify product or fabrication or installation method to be replaced. Include Specification Section number and title and Drawing numbers and titles.
 - 1. Include data to indicate compliance with the requirements specified in "Comparable Products" Article.
 - 2. Architect's Action: If necessary, Architect will request additional information or documentation for evaluation within one week of receipt of a comparable product request. Architect will notify Contractor of approval or rejection of proposed

comparable product request within 15 days of receipt of request, or seven days of receipt of additional information or documentation, whichever is later.

- a. Form of Approval: As specified in Section 01 33 00 "Submittal Procedures."
- b. Use product specified if Architect does not issue a decision on use of a comparable product request within time allocated.

1.5 QUALITY ASSURANCE

- A. Compatibility of Options: If Contractor is given option of selecting between two or more products for use on Project, select product compatible with products previously selected, even if previously selected products were also options.

1.6 PRODUCT DELIVERY, STORAGE, AND HANDLING

- A. Deliver, store, and handle products using means and methods that will prevent damage, deterioration, and loss, including theft and vandalism. Comply with manufacturer's written instructions.
- B. Delivery and Handling:
 1. Coordinate delivery with installation time to ensure minimum holding time for items that are flammable, hazardous, easily damaged, or sensitive to deterioration, theft, and other losses.
 2. Deliver products to Project site in an undamaged condition in manufacturer's original sealed container or other packaging system, complete with labels and instructions for handling, storing, unpacking, protecting, and installing.
 3. Inspect products on delivery to determine compliance with the Contract Documents and to determine that products are undamaged and properly protected.
- C. Storage:
 1. Store products off-site until ready for delivery.
 2. Store products to allow for inspection and measurement of quantity or counting of units.
 3. Store products that are subject to damage by the elements, under cover in a weathertight enclosure above ground, with ventilation adequate to prevent condensation.
 4. Comply with product manufacturer's written instructions for temperature, humidity, ventilation, and weather-protection requirements for storage.
 5. Protect stored products from damage and liquids from freezing.

1.7 PRODUCT WARRANTIES

- A. Warranties specified in other Sections shall be in addition to, and run concurrent with, other warranties required by the Contract Documents. Manufacturer's disclaimers and limitations on product warranties do not relieve Contractor of obligations under requirements of the Contract Documents.
 1. Manufacturer's Warranty: Written warranty furnished by individual manufacturer

2. for a particular product and specifically endorsed by manufacturer to Owner.
Special Warranty: Written warranty required by the Contract Documents to provide specific rights for Owner.
- B. Special Warranties: Prepare a written document that contains appropriate terms and identification, ready for execution.
 1. Manufacturer's Standard Form: Modified to include Project-specific information and properly executed.
 2. See other Sections for specific content requirements and particular requirements for submitting special warranties.
- C. Submittal Time: Comply with requirements in Section 01 77 00 "Closeout Procedures."

PART 2 - PRODUCTS

2.1 PRODUCT SELECTION PROCEDURES

- A. General Product Requirements: Provide products that comply with the Contract Documents, are undamaged and, unless otherwise indicated, are new at time of installation.
 1. Provide products complete with accessories, trim, finish, fasteners, and other items needed for a complete installation and indicated use and effect.
 2. Standard Products: If available, and unless custom products or nonstandard options are specified, provide standard products of types that have been produced and used successfully in similar situations on other projects.
 3. Owner reserves the right to limit selection to products with warranties not in conflict with requirements of the Contract Documents.
 4. Where products are accompanied by the term "as selected," Architect will make selection.
 5. Descriptive, performance, and reference standard requirements in the Specifications establish salient characteristics of products.
- B. Product Selection Procedures:
 1. Product: Where Specifications name a single manufacturer and product, provide the named product that complies with requirements. Comparable products or substitutions for Contractor's convenience will not be considered.
 2. Manufacturer/Source: Where Specifications name a single manufacturer or source, provide a product by the named manufacturer or source that complies with requirements. Comparable products or substitutions for Contractor's convenience will not be considered.
 3. Products:
 - a. Restricted List: Where Specifications include a list of names of both manufacturers and products, provide one of the products listed that complies with requirements. Comparable products or substitutions for Contractor's convenience will not be considered.
 - b. Nonrestricted List: Where Specifications include a list of names of both available manufacturers and products, provide one of the products listed, or an unnamed product, that complies with requirements. Comply with

requirements in "Comparable Products" Article for consideration of an unnamed product.

4. Manufacturers:
 - a. Restricted List: Where Specifications include a list of manufacturers' names, provide a product by one of the manufacturers listed that complies with requirements. Comparable products or substitutions for Contractor's convenience will not be considered.
 - b. Nonrestricted List: Where Specifications include a list of available manufacturers, provide a product by one of the manufacturers listed, or a product by an unnamed manufacturer, that complies with requirements. Comply with requirements in "Comparable Products" Article for consideration of an unnamed manufacturer's product.

2.2 COMPARABLE PRODUCTS

- A. Conditions for Consideration: Architect will consider Contractor's request for comparable product when the following conditions are satisfied. If the following conditions are not satisfied, Architect may return requests without action, except to record noncompliance with these requirements:
 1. Evidence that the proposed product does not require revisions to the Contract Documents, that it is consistent with the Contract Documents and will produce the indicated results, and that it is compatible with other portions of the Work.
 2. Detailed comparison of significant qualities of proposed product with those named in the Specifications. Significant qualities include attributes such as performance, weight, size, durability, visual effect, and specific features and requirements indicated.
 3. Evidence that proposed product provides specified warranty.

PART 3 - EXECUTION (Not Used)

END OF SECTION 01 60 00

SECTION 01 77 00 - CLOSEOUT PROCEDURES

PART 1 - GENERAL

1.1 RELATED DOCUMENTS

- A. Drawings and general provisions of the Contract, including General and Supplementary Conditions and other Division 01 Specification Sections, apply to this Section.

1.2 SUMMARY

- A. Section includes administrative and procedural requirements for contract closeout, including, but not limited to, the following:
 - 1. Substantial Completion procedures.
 - 2. Final completion procedures.
 - 3. Warranties.
- B. Related Requirements:
 - 1. Section 01 78 23 "Operation and Maintenance Data" for operation and maintenance manual requirements.

1.3 MAINTENANCE MATERIAL SUBMITTALS

- A. Schedule of Maintenance Material Items: For maintenance material submittal items specified in other Sections.

1.4 SUBSTANTIAL COMPLETION PROCEDURES

- A. Contractor's List of Incomplete Items: Prepare and submit a list of items to be completed and corrected (Contractor's punch list), indicating the value of each item on the list and reasons why the Work is incomplete.
- B. Submittals Prior to Substantial Completion: Complete the following a minimum of 10 days prior to requesting inspection for determining date of Substantial Completion. List items below that are incomplete at time of request.
 - 1. Submit closeout submittals specified in individual Sections, including specific warranties, workmanship bonds, maintenance service agreements, final certifications, and similar documents.
 - 2. Submit maintenance material submittals specified in individual Sections, including tools, spare parts, extra materials, and similar items, and deliver to location designated by Construction Manager. Label with manufacturer's name and model number where applicable.
 - a. Schedule of Maintenance Material Items: Prepare and submit schedule of maintenance material submittal items, including name and quantity of each item and name and number of related Specification Section. Obtain

Construction Manager's signature for receipt of submittals.

1.5 FINAL COMPLETION PROCEDURES

- A. Submittals Prior to Final Completion: Before requesting final inspection for determining final completion, complete the following:
1. Submit a final Application for Payment according to Section 01 29 00 "Payment Procedures."
 2. Certified List of Incomplete Items: Submit certified copy of Architect's Substantial Completion inspection list of items to be completed or corrected (punch list), endorsed and dated by Architect. Certified copy of the list shall state that each item has been completed or otherwise resolved for acceptance.

1.6 LIST OF INCOMPLETE ITEMS (PUNCH LIST)

- A. Organization of List: Include name and identification of each space and area affected by construction operations for incomplete items and items needing correction including, if necessary, areas disturbed by Contractor that are outside the limits of construction. Use CSI Form 14.1A.
1. Organize list of spaces in sequential order, proceeding from lowest floor to highest floor.
 2. Organize items applying to each space by major element, including categories for ceiling, individual walls, floors, equipment, and building systems.
 3. Include the following information at the top of each page:
 - a. Project name.
 - b. Date.
 - c. Name of Architect and Construction Manager.
 - d. Page number.
 4. Submit list of incomplete items in the following format:
 - a. MS Excel electronic file. Architect, through Construction Manager, will return annotated file.

1.7 SUBMITTAL OF PROJECT WARRANTIES

- A. Time of Submittal: Submit written warranties on request of Architect for designated portions of the Work where commencement of warranties other than date of Substantial Completion is indicated, or when delay in submittal of warranties might limit Owner's rights under warranty.
- B. Organize warranty documents into an orderly sequence based on the table of contents of Project Manual.
1. Bind warranties and bonds in heavy-duty, three-ring, vinyl-covered, loose-leaf binders, thickness as necessary to accommodate contents, and sized to receive 8-1/2-by-11-inch paper.
 2. Provide heavy paper dividers with plastic-covered tabs for each separate warranty. Mark tab to identify the product or installation. Provide a typed

description of the product or installation, including the name of the product and the name, address, and telephone number of Installer.

3. Identify each binder on the front and spine with the typed or printed title "WARRANTIES," Project name, and name of Contractor.
4. Warranty Electronic File: Scan warranties and bonds and assemble complete warranty and bond submittal package into a single indexed electronic PDF file with links enabling navigation to each item. Provide bookmarked table of contents at beginning of document.

- C. Provide additional copies of each warranty to include in operation and maintenance manuals.

PART 2 - PRODUCTS (Not Used)

PART 3 - EXECUTION (Not Used)

END OF SECTION 01 77 00

SECTION 01 78 23 - OPERATION AND MAINTENANCE DATA

PART 1 - GENERAL

1.1 RELATED DOCUMENTS

- A. Drawings and general provisions of the Contract, including General and Supplementary Conditions and other Division 01 Specification Sections, apply to this Section.

1.2 SUMMARY

- A. Section includes administrative and procedural requirements for preparing operation and maintenance manuals, including the following:
 - 1. Product maintenance manuals.
- B. Related Requirements:
 - 1. Section 01 33 00 "Submittal Procedures" for submitting copies of submittals for operation and maintenance manuals.

1.3 DEFINITIONS

- A. System: An organized collection of parts, equipment, or subsystems united by regular interaction.
- B. Subsystem: A portion of a system with characteristics similar to a system.

1.4 CLOSEOUT SUBMITTALS

- A. Manual Content: Operations and maintenance manual content is specified in individual Specification Sections to be reviewed at the time of Section submittals. Submit reviewed manual content formatted and organized as required by this Section.
 - 1. Architect[and Commissioning Authority] will comment on whether content of operations and maintenance submittals are acceptable.
 - 2. Where applicable, clarify and update reviewed manual content to correspond to revisions and field conditions.
- B. Format: Submit operations and maintenance manuals in the following format:
 - 1. PDF electronic file. Assemble each manual into a composite electronically indexed file. Submit on digital media acceptable to Architect.
 - a. Name each indexed document file in composite electronic index with applicable item name. Include a complete electronically linked operation and maintenance directory.
- C. Final Manual Submittal: Submit each manual in final form prior to requesting inspection

for Substantial Completion and at least [15] <Insert number> days before commencing demonstration and training. Architect[and Commissioning Authority] will return copy with comments.

PART 2 - PRODUCTS

2.1 PRODUCT MAINTENANCE MANUALS

- A. Content: Organize manual into a separate section for each product, material, and finish. Include source information, product information, maintenance procedures, repair materials and sources, and warranties and bonds, as described below.
- B. Source Information: List each product included in manual, identified by product name and arranged to match manual's table of contents. For each product, list name, address, and telephone number of Installer or supplier and maintenance service agent, and cross-reference Specification Section number and title in Project Manual and drawing or schedule designation or identifier where applicable.
- C. Product Information: Include the following, as applicable:
 - 1. Product name and model number.
 - 2. Manufacturer's name.
 - 3. Color, pattern, and texture.
 - 4. Reordering information for specially manufactured products.
- D. Maintenance Procedures: Include manufacturer's written recommendations and the following:
 - 1. Inspection procedures.
 - 2. Types of cleaning agents to be used and methods of cleaning.
 - 3. List of cleaning agents and methods of cleaning detrimental to product.
 - 4. Schedule for routine cleaning and maintenance.
- E. Warranties and Bonds: Include copies of warranties and bonds and lists of circumstances and conditions that would affect validity of warranties or bonds.
 - 1. Include procedures to follow and required notifications for warranty claims.

PART 3 - EXECUTION

3.1 MANUAL PREPARATION

- A. Product Maintenance Manual: Assemble a complete set of maintenance data indicating care and maintenance of each product, material, and finish incorporated into the Work.
- B. Manufacturers' Data: Where manuals contain manufacturers' standard printed data, include only sheets pertinent to product or component installed. Mark each sheet to identify each product or component incorporated into the Work. If data include more than one item in a tabular format, identify each item using appropriate references from the Contract Documents. Identify data applicable to the Work and delete references to information not applicable.

1. Prepare supplementary text if manufacturers' standard printed data are not available and where the information is necessary for proper operation and maintenance of equipment or systems.
- C. Drawings: Prepare drawings supplementing manufacturers' printed data to illustrate the relationship of component parts of equipment and systems and to illustrate control sequence and flow diagrams. Coordinate these drawings with information contained in record Drawings to ensure correct illustration of completed installation.
1. Do not use original project record documents as part of operation and maintenance manuals.
- D. Comply with Section 01 77 00 "Closeout Procedures" for schedule for submitting operation and maintenance documentation.

END OF SECTION 01 78 23

PART 1 -GENERAL

1.00 SUMMARY

A. Systems

1. The Audiovisual systems reference the systems specifically identified for the Joliet Junior College City Center Project. These systems are identified as:
 - a. Chef's Table and Private Dining
 - b. Culinary Labs, including:
 - 1) Demonstration Lab & Control Room
 - 2) Competition Lab
 - 3) Garde Manger
 - 4) Baking & Pastry Labs
 - 5) Production Labs
 - 6) Meat Lab
 - c. Student Dining and Servery
 - d. AV Rack & Equipment Room
 - e. Classrooms
 - f. General Student Spaces
 - g. Administration Spaces
 - h. Portable Equipment Pool
2. The audiovisual systems within these spaces are intended to provide:
 - a. Video display of instructional and culinary demonstration processes
 - b. Sound reinforcement of instructors and presenters for specific spaces as noted
 - c. Video and Audio switching and distribution of culinary events from one space to other room AV systems for viewing and listening
 - d. Control of AV systems in the AV Control Room, as well as individual touch panels and/or iOS tablet control surfaces in specific spaces
 - e. Video display provisions for security monitoring and testing center monitoring
 - f. AV support for standard classrooms
 - g. Video display and AV inputs for group study, tutoring, conferences, reception, etc.
 - h. Video display provision for digital signage content at specific locations
 - i. AV support for private dining events and culinary competition events
 - j. Provision for Assistive Listening Systems as required by 2010 ADA

1.01 WORK INCLUDES

A. Base Bid: General Contractor

1. Engage the subcontractor services of a fully certified and authorized AV systems contractor. Reference section herein for requirements and basis of qualifications.
2. Provide audio visual systems design, engineering, and installation within all phases and spaces of the Project. Systems are to include all devices, equipment, installation, programming and commissioning in accordance with requirements of the contract documents and drawings.
3. The Work detailed within the Contract Documents has been specified to meet certain requirements for performance, appearance, and costs. It shall be the responsibility of the Contractor to implement the guidelines and requirements contained in the Contract Documents and translate them into a complete design package containing all elements necessary for a complete, operational, and functionally integrated Audio Visual System(s).
4. Provide all work as detailed in the Contract Documents as a turnkey installation including all material, labor, engineering, warranties, taxes, freight, and permits. Only items and

requirements specifically stated to be provided by others shall not be a requirement for this Section of the Work.

B. Work Included:

1. Equipment and installation labor as noted on the Contract Documents for a fully functional system. Miscellaneous components, hardware, interconnections and terminations required for proper operation of all systems.
2. All components or systems indicated on the Contract Documents.
3. The Installing Contractor shall be responsible for the following:
 - a. Verification of accuracy and completeness of equipment lists, dimensions, mounting details and equipment compatibility
 - b. Accurate documentation of the system operation and installation.
 - c. One year warranty of the equipment and installation.
 - d. Test equipment, tools, ladders, lifts and scaffolding required for installation.
 - e. Daily and final cleanup of debris caused by installation.
 - f. Quality Control / Commissioning of system
 - g. Perform Contractor System Checkout per section 3.04.
 - h. Perform System Acceptance Tests per section 3.05.
 - i. End user training and training manuals Systems.

C. Work Specified Elsewhere

1. Installation of raceway, pull-boxes, plywood backboards and floor-boxes (provided under electrical Work). Coordination is required within the design to verify the appropriate raceways are in place.
2. Provision of data systems connectivity and switching.
3. Cutting, patching and painting of walls, unless damaged performing the work described herein.

D. Coordinated Work

1. Coordinate all wall-mounted, ceiling-mounted and floor mounted devices with General Contractor and University staff.
2. Coordinate with related trades to schedule the Work and ensure a complete installation in accordance with the schedule outlined by the GC.
3. Coordinate the provision of data network(s) and electrical power systems as referenced in the AV drawing sheets.

1.02 ALTERNATES

- A. The AV contractor shall, at their discretion, provide any deduct alternates as a part of the bid submittal process. These deduct alternates shall be submitted to the Architect and AV Consultant for approval two weeks prior to bid submittal due date.

1.03 REFERENCE STANDARDS

A. Code Compliance

1. The Audio Visual Systems shall be installed in accordance with the latest applicable revisions pertaining to all applicable national, state, and local codes and standards including, but not limited to the following:
 - a. National Electrical Code (NEC), current state recognized edition.
 - b. Uniform Building Code (UBC), current state recognized edition.
 - c. Local Governing Authorities Having Jurisdiction
 - d. ANSI/NFPA 70 National Electrical Code.

- e. ANSI/IEEE C2 National Electrical Safety Code TIA/EIA Standards 568 A (including TSB 67), and 607.
- f. IEE/ANSI 142 1982 Recommended Practice for Grounding of Industrial and Commercial Power Systems.
- g. ANSI/TIA-569B Commercial Building Standard for Telecommunications Pathways and Spaces
- h. NFPA 72-2010; National Fire Alarm and Signaling Code [intelligibility requirements]
- i. Illinois Accessibility Code

1.04 INFORMATION TO BE SUBMITTED WITH THE BID RETURN

A. Equipment Costs

- 1. The bid return shall include detailed lists of all equipment to be supplied. Each piece of equipment shall be individually priced. Equipment lists are provided herein under the Detailed Specifications. Copies of these lists shall be used, with the appropriate price information added.
- 2. In the event that the equipment list spreadsheet is made available to the bidders electronically, SM&W is not responsible for any formulas that may be resident in the spreadsheet. The results of any calculations in the spreadsheet are the sole responsibility of the Bidder.
 - a. The design intent of the system may require equipment not listed in the attached spreadsheet, but are indicated elsewhere in the contract documents, in either the drawings or the written specification. It is the sole responsibility of the Bidder to reconcile the contract documents with the equipment and labor required for this project.
 - b. No claims for additional equipment required will be allowed, if the sole reason for such claims is that the equipment was not listed in the attached spreadsheet. It is the sole responsibility of the Bidder to verify the completeness of the equipment list.
 - c. Equipment costs shall reflect all required modifications, additional equipment, and accessories. All substitutions for specified equipment shall be listed and individually priced on a separate page as an alternate to the specified equipment. Listing and pricing for the original equipment shall still be provided as part of the bid return.
 - d. Equipment totals from each equipment list shall be entered in the Master Recapitulation of Costs form.

B. Non-Equipment Costs

- 1. Non-equipment costs shall be furnished separately on the Master Recapitulation of Costs form. These non-equipment costs shall be detailed for each of the following categories:
 - a. Engineering: Including all required designs, drawings, run sheets, instruction manuals, etc.
 - b. Pre-installation: Including all fabrication, modification, assembly, rack wiring, etc., performed on the Contractor's premises.
 - c. Installation: Including all on-site installation and wiring, coordination and supervision, testing, checkout, Owner training, etc. performed on the Owner's premises.
 - d. General and Administrative: Including all 'G & A' expenses, shipping, insurance, and guarantees.
 - e. Taxes.

- C. General Information on the bidders' firm should include the following information:
1. The number of years in business.
 2. Resumes of key personnel. Resumes must reflect skills relating to audio, video, teleconferencing (audio and video), integrated control systems, programming, project management, etc.
 3. Locations of all currently staffed and operational offices complete with the number of technical support personnel in each office.
- D. Project References (minimum of three (3) required; consultant specified jobs) These should include:
1. End user contact name, with current telephone number and e-mail address.
 2. Functional description of the project.
 3. Project scope and approximate dollar amount (single projects should be equivalent to the size of this project, not accumulative work of a single client).
 4. Completion date.
 5. All projects identified must be verifiable, and have been completed within the last twelve (12) months.
- E. List of products for which the firm is a direct dealer, including the duration of the dealership and the extent of any factory training. This list should include, but not be limited to:
1. Large screen display systems, both projection and display-type, including but not limited to Plasma, LCD (both fluorescent and LED back-lit as applicable), DLP/DMD and LCOS.
 2. Specialized display systems (as applicable).
 3. Video switching/routing, scaling, conversion, and distribution systems.
 4. Computer controlled audio systems including but not limited to audio digital signal processors and distribution systems.
 5. Integrated control systems.
 6. Video conference systems.
 7. Video and Audio Broadcast systems.
 8. IT and Telecommunications equipment as used in Audiovisual systems implementations/installations.
- F. List of technical products that the firm has installed and serviced, but are not a direct dealer for.
- G. Warranty Statement
1. To maintain certain manufacturer's warranties, said equipment must be installed, aligned and serviced by those installers authorized by said manufacturer to perform those duties. If the contractor is not authorized, by said manufacturer, it is his sole responsibility to make the appropriate arrangements and bear all cost and consequences thereof.
 2. The Bidder shall include a statement of warranty on the entire system and on the individual pieces of equipment. The system warranty shall be for a minimum of 365 days from the date of commissioning by the Owner and Consultant (refer to "Commissioning Test" for requirements). This warranty shall obligate the Contractor to provide all equipment, material, and labor at no charge to the Owner, during the warranty period, in the event of a system or equipment malfunction.

3. In cases where the manufacturer's warranty period is greater than twelve months, the contractor is required to honor that warranty for the full extent of the manufacturer's warranty period. This shall exclude any labor costs incurred by the contractor removing and re-installing the defective items after the system warranty expiration.
4. In cases where the manufacturer's warranty period is less than 12 months, the contractor is liable for defects in the item up to-but not exceeding-the first twelve-month period on any contractor provided items.
5. The system warranty shall include a minimum of four (4) preventative maintenance visits, to perform operation checks of the equipment, screens, projector lenses and other critical surfaces, to lubricate moving parts as recommended by the respective manufacturers and to adjust and align projector(s) to maintain optimum registration and focus.
6. All manufacturers' equipment warranties shall be activated in the Owner's name and shall commence on the date that commissioning is completed. In the case of Contractor-modified equipment, the manufacturer's warranty is normally voided. In such cases, the Contractor shall provide the Owner with a warranty equivalent to that of the original manufacturer.
7. In the event of malfunction or failure of any audiovisual equipment provided by the AV integrator, the integrator is responsible for providing replacement of faulty equipment, or providing "loaner" equipment. In the event that "loaner" equipment is provided, said equipment shall meet or exceed the original equipment specifications until the original equipment can be replaced.
8. In Cases where the contractor is providing and installing audiovisual equipment and/or hardware to be integrated with equipment furnished by others, it shall be the responsibility of the contractor to warrant their equipment as described herein; unless said equipment shows misuse and or abuse by others during re-installation of, or connection of equipment by others.
9. Telephone Support
 - a. The Audiovisual Contractor shall respond via telephone within two (2) hours to any request for service. This first contact should outline the nature of the problem or functional anomaly. The AV Contractor shall make available an individual knowledgeable with the installed system, and who can address specific system issues described by the system operators.
10. On-Site Support
 - a. The system warranty shall be an "on-site" warranty, with a twenty-four (24) hour response time. The Bidder shall include alternate pricing for four (4) hour response time. Telephone support shall be available between normal business hours, Monday through Friday.

H. Preventative Maintenance & Service Contract

1. In addition to the preventative maintenance visits described herein, the Bidder shall offer a separate annual preventative maintenance contract by pricing for five (5) years on a year-to-year basis. This preventative maintenance contract shall cover all installed systems and include a minimum of four (4) visits per year, at regular intervals, to perform operation checks of the equipment, clean filters, screens, projector lenses and other critical surfaces, to lubricate moving parts like screens and lifts as recommended by the respective manufacturers and to adjust and align projectors to maintain optimum registration and focus. The preventative maintenance contract is an option for the Owner to exercise immediately after expiration of the warranty period. (A per item price for the service contract shall be submitted with the bid).
2. The Bidder shall also submit separate costs for other emergency "on-call" service visits and an "in-shop" hourly rate for repair and maintenance work.

3. The costs for this service contract shall not be commingled with the costs for the systems base bid.
- I. Schedule of Implementation
1. It is the responsibility of the bidder to verify the project schedule and confirm via their bid return that they will comply with the project schedule and deliver a complete audiovisual system within the specified time frame.
 2. Bidders may indicate their acceptance of the project schedule by submitting a scheduling plan with the bid return, indicating the various pertinent terminal dates after award of contract for completion of design, pre-installation work, on-site installation work, and testing and acceptance on a “per phase” basis.
 3. At a minimum the schedule should include the following information:
 - a. Number of days required for submission of engineering documents from receipt of notice to proceed.
 - b. Days to complete the project from receipt of approved documents. This information should be broken down to indicate benchmark dates of other trades and days to completion of tasks associated with those benchmarks.
 - c. If provided, the Bidder shall review attached cover documents and schedule for additional information.
- J. Alternate Equipment
1. All bids shall be submitted on the basis of the specified equipment. The Bidder may propose alternate equipment. However, all such proposals shall be submitted separately and will be identified as “alternates” with equipment costs shown separate and apart from the costs of the equipment “as specified”.
 2. Proposals for alternate equipment will receive careful and equitable consideration if the differences do not depart from the overall intent of the design and operation of the system, are in the best interests of the Owner, and are equal in durability and usability.
 3. All such proposals for alternate equipment shall be accompanied by full technical information, “cuts” and specifications for the equipment so proposed. The Bidder shall identify the substantive differences between the alternate and the specified equipment.
 4. All Alternates must be submitted for pre-approval.
- K. Exceptions and Proposed Modifications
1. Should the Bidder have recommendations, which will enhance the performance of the system, or reduce costs without loss of performance, such comments shall be made in the bid submission. All suggestions that are of value to the Owner will be taken into consideration in the evaluation of the bid returns. All such proposals shall be made as “alternates”, with the appropriate cost modifications shown separate and apart from the costs of the system “as specified”.
 2. Any and all exceptions to these specifications and related drawings must be made with the bid submission. In the absence of exceptions, these specifications and related drawings shall be binding in letter and intent on the successful Bidder. It will further be assumed that the Bidder has examined the design and specifications in detail, and is prepared to take full responsibility for the performance of the complete installation as designed and specified.

L. Sub-Contract Information

1. If the Bidder proposes to sub-contract portions of the work, such sub-contractors shall be identified and their responsibilities and qualifications detailed in the Bidder's bid submission. The work as performed by a sub-contractor shall be considered as part of the contractor's responsibility with that work as part of the contractor's statement. Any contract arising as a direct result of these proceedings shall be binding on the successful bidder and the terms of said contract shall be submitted with the bid return.

M. Specification Drawings

1. All drawings referred to herein are furnished with and become an integral part of this specification. These drawings and specifications shall remain the property of the Owner and hard copies shall be returned or destroyed by all unsuccessful bidders, within 10 days after formal notification.

N. Investigation of Contractual and Scheduling Questions

1. It shall be the responsibility of the Bidder to investigate all potential contract, union, and scheduling questions, and to guarantee compliance with all requirements and regulations in effect on the job site. Any potential problems in this respect shall be identified in the bid return. The contractor shall comply with all local state and federal regulations.

1.05 SUBMITTALS

A. Sequence

1. Prior to commencement of shop drawing process, AV Contractor shall coordinate with the Architect and the Owner with regard to the following items:
 - a. Location and installation of all flat panel displays
 - b. Location and installation of all video cameras
 - c. Location and installation of all loudspeakers in all ceiling types and walls
 - d. Location and installation of all iPad tablet control devices
 - e. Location and installation of all local podiums, lecterns, etc. regarding local AV devices
 - f. Location and installation of all cable cubby devices
 - g. Location and installation of all video projectors and projection screens
 - h. Confirm that all requisite power, data and AV infrastructure is in place and properly installed
2. Shop Drawings - Upon award of Contract, submittals shall be prepared and submitted for review by Architect and AV Consultant prior to commencement of any work.
3. Record Documents - Upon completion of systems and AV Contractor System Check Out, Record Documents to be created and submitted for review prior to system final acceptance.
4. Operation and Maintenance Manuals– Shall be produced for review prior to Training.

B. Procedure

1. Furnish submittals in accordance with general requirements specified in Division 1 - SUBMITTAL PROCEDURES

C. Prefabrication Submittals

1. Submit pre-fabrication submittals in accordance with the GC's construction schedule.
2. Pre-fabrication submittals shall consist of product data, shop drawings, samples, and a detailed completion schedule. Partial submittals will not be accepted without prior written approval from the Architect.
3. Pre-fabrication submittals shall be furnished in electronic formats as defined by the General Conditions under Part 1 of the Project Specifications.
4. No portion of the Work shall commence nor shall any equipment be procured until the Architect has approved the pre-fabrication submittals in writing.
5. A letter of transmittal identifying the name of the Project, AV Contractor's name, date submitted for review, shall accompany pre-fabrication submittals and a list of items transmitted.
6. Product data required as part of the pre-fabrication submittal shall include the following:

D. Product Submittals

1. Equipment schedules listing all System components, manufacturer, model number and the quantity of each
2. Submit manufacturer's product data sheets for all materials and equipment proposed for use on the project sorted by room and indexed.
 - a. Mark each product data sheet to show applicable choices and options (sheets containing more than one device or component model number shall be clearly marked to delineate items included in the Work)
3. Submit manufacturer's product data sheets for all fire stopping materials proposed for use on the project.
4. A complete list of finishes and sample graphics, including custom art work and custom graphics (if applicable)
5. DSP Program Matrix drawings or program print out.
6. Video Matrix Program Drawings or program print out.

E. Project Calculations

1. Cable run sheets denoting cable type, signal type, termination type, cable number designation, start point and end point.
2. Confirmation of all projection lens/screen size/throw distance parameters
3. Confirmation of distance limitations for digital AV (HDBT) signal transmittals.

F. Shop Drawings

1. Cable termination schedules showing cable transmission and device location. Provide schedules in printed and electronic format.
2. Floor plan drawings indicating device locations with device legends
3. System riser diagram with all devices, wire runs, and wire designations
4. Schematic block diagrams for each System showing all equipment, interconnects, data flow, etc.
5. Fabrication shop drawings for all custom equipment (if applicable)

6. Plans and elevations of the Audiovisual equipment racks and/or custom furniture (including consoles, desks, and lecterns) quantifying all equipment to be mounted therein.
7. It is the responsibility of the AV Contractor to confirm all dimensions, quantities, and the coordination of materials and products supplied by the AV Contractor with other trades. Approval of shop drawings containing errors does not relieve the AV Contractor from making corrections at their expense.

G. Samples

1. The AV Contractor shall submit samples of any equipment components upon request of the Architect.
2. Samples submitted shall be the latest version of equipment.

H. Record Documents

1. Shall include all information required in the Pre-fabrication Submittals but revised to reflect “as installed” conditions.
2. General Description and Requirements
 - a. Submit Record Documentation in accordance with Division 1 section “Closeout Submittals.”
 - b. Provide cable test results for all cables installed under this Work, tested and documented as described herein.
 - c. Provide the Architect and AV consultant with all systems programming on electronic media. The AV contractor is granted the rights to use and modify the code for the systems specified within this scope of work.
3. Record Drawings
 - a. Produce all Record “as-built” Drawings using the latest version of AutoCAD and in PDF format. Record drawings shall, at a minimum, include the following:
 - 1) Floor plan drawings indicating device locations, with device legends indicating manufacturers and model numbers for each device
 - 2) Floor plan drawings indicating wire routing, wire routing shall be delineated in straight line runs and be tagged with cable identification and terminal strip numbers to coincide with the installation
 - 3) Mounting details for all equipment and hardware
 - 4) Functional block diagrams for each subsystem
 - 5) Wiring details showing rack elevations, equipment wiring and terminations, and inter-rack wiring
 - 6) Wiring diagrams for each System, wiring diagrams shall be identical to those laminated and located within the door of the equipment rack or other storage location designated by the University
 - 7) Typical point-to-point wiring diagrams for each piece of equipment and groups of equipment within the System
 - 8) Layout details for each riser location, including Audiovisual panels, power supplies, junction boxes, conduit, and any other Audiovisual related equipment
4. Operation and Maintenance Manuals
 - a. Operation and Maintenance Manuals shall apply to all Audio Visual related devices, equipment and software modules.
 - 1) Operation and Maintenance Manuals shall be formatted in accordance with Division 1 section “Closeout Submittals.”
 - b. Operation and Maintenance Manuals shall include, at a minimum, the following:
 - 1) Operational description of each subsystem
 - 2) Detailed programming descriptions for each subsystem
 - 3) Explanations of subsystem interrelationships
 - 4) Electrical schematics for each piece of equipment specified

- 5) Power-up and power-down procedures for each subsystem
 - 6) Description of all diagnostic procedures
 - 7) A list of manufacturers, their local representatives, and subcontractors that have performed Work on the Project
 - 8) Installation and service manuals for each piece of equipment
 - 9) Maintenance schedules for all installed components
 - c. Make corrections or changes in O & M and/or Record Drawings as required by the Architect and resubmit when the Architect's stamp requires re-submittal.
 - d. Clearly identify changes made other than those specifically requested by the Architect when resubmitting Record Drawings. Changes shall be clouded or similarly highlighted as coordinated with the Architect. Only changes that have been specifically requested by the Architect or have been clouded by the AV Contractor will be reviewed on resubmittals.
 - e. Any drawing sheets added to the resubmittal shall be clearly identified and clouded, and shall not change the sheet numbering scheme for previously issued Record Drawings.
 - f. The AV Contractor shall be responsible for any delays caused by the re-submittal process.
5. Re-Submittal Review Fees RE-SUBMITTAL REVIEW FEES
- a. If the Architect rejects the AV Contractor's Record Submittal (Rejected, Revise, and Resubmit) more than two times, the Architect will be compensated for all subsequent reviews, whether partial or comprehensive. The amount of such compensation will be incorporated by Change Order and withheld from the AV Contractor's Application for Payment.

1.06 QUALITY ASSURANCE

A. Contractor Qualifications

1. Work specified herein shall be the responsibility of a single AV Contractor, as a certified subcontractor to the electrical contractor. Bid submission shall document a minimum of five (5) years of experience in the fabrication, assembly, installation and testing of Systems of similar complexity and project size as specified herein. The documentation shall include the names, locations, and points of contact for at least three (3) installations of the type and complexity specified herein.
2. Each bidder shall have at least one supervisory employee on this project possessing a certificate, from Infocomm International or another recognized organization or institution providing formal training in audiovisual engineering and/or installation. Proof of this shall be supplied with bid.
3. All employees of the contractor to install this system must be competent technicians who are experienced in the installation and interconnection of professional audiovisual systems.
4. All engineering and project management is to be handled by a qualified, full-time employee of the audiovisual contractor. No outsourcing or sub-contracting of this phase will be accepted.
5. Each bidder shall maintain an adequately equipped and staffed service department and shall regularly provide service for systems similar to this design. This shall include an office staffed with personnel at all times, Monday through Friday, between the hours of 9:00 AM and 5:00 PM. Answering services, cellular telephones, pager numbers and call forwarding systems are helpful but do not meet nor comply with the intent of this specification.
6. Each bidder shall be currently authorized by the manufacturer of the major components of the system to sell their products and initiate warranty service on the same items. Major components of the system shall include, but not be limited to, data/video projectors and displays; video distribution, processing and switching equipment; audio distribution and

processing equipment; power amplifiers, speakers, etc. Proof of this may be requested during the bidding process. Proof of franchise shall be in the form of a letter from the appropriate manufacturer addressed to the Owner's Representative stating that the contractor is currently authorized to sell their products. Letters from the sales representative (rep) shall not be accepted as proof.

7. Quality assurances for audio visual systems includes a multi-step program consisting of pre-qualification procedure for manufacturers and installation specialists; products phase; installation; operating instruction and training; and the submission of maintenance and operating manuals.
8. The AV Contractor shall have local in-house engineering and project management capabilities consistent with the requirements of the Work.
9. By submitting a bid, the AV Contractor thereby certifies that it is qualified in all areas pertaining to, directly or indirectly, the Work. In the event the AV Contractor becomes unable to complete the Work in accordance with the Contract Documents, or the satisfaction of the Architect, it shall be the responsibility of the AV Contractor to retain the services of applicable manufacturers' representatives to expeditiously complete the Work in accordance with the GC's construction schedule with no additional cost to the Owner.
10. The AV Contractor shall maintain, or establish and maintain, a fully staffed office including a service center capable of providing maintenance and service to the Project. The Contractor shall staff the service center with factory trained technicians and adequately equip the office to provide emergency service within seventy-two (72) hours after being called, 24 hours per day.
11. The AV Contractor shall provide factory-certified technicians to install, commission, and maintain the Work. All installing personnel shall be licensed as required by local and/or state jurisdictions.
12. The AV Contractor shall ensure compliance with, and have a thorough understanding of, all local codes and contract conditions pertaining to this Project.
13. The AV Contractor shall maintain an inventory of spare parts and other items critical to System operation and as necessary to meet the emergency service requirements of this Project within the local service center.

B. Project Standards

1. All equipment and materials for contained herein shall be the products of recognized manufacturers and shall be new.
2. New equipment and materials shall:
 - a. Be Underwriters Laboratories, Inc. (U.L.) listed and approved where specifically called for; or where normally subject to such U.L. labeling and/or listing services.
 - b. Be without blemish or defect.
 - c. Be products that meet with the acceptance of the agency inspecting the Audio Visual Systems work.
3. It is the intent of these specifications that wherever a manufacturer of a product is specified, and the terms "other approved" or "approved equal" are used, the substituted item must conform in all respects to the specified item. Consideration will not be given to claims that the substituted item meets the performance requirements with lesser construction. Performance as delineated in schedules and in the specifications shall be interpreted as minimum performance.
4. Substituted equipment or optional equipment, where permitted and approved, must conform to space requirements. Any substituted equipment that cannot meet space requirements, whether approved or not, shall be replaced at the AV Contractor's expense. Any modifications of related Systems as a result of substitutions shall be made at the AV Contractor's expense.

5. The approval of shop drawings, or other information submitted in accordance with the requirements herein before specified, does not ensure that the AV Consultant or the Architect attest to the dimensional accuracy, dimensional suitability of the material, or mechanical performance of equipment. Approval of shop drawings does not invalidate the Drawings and Specifications.
6. Substitutions of equipment shown on the schedules or designated by model number in the specifications will not be considered if the item is not a regular catalogued item carried by the manufacturer.
7. Within the Specifications, certain manufacturers have been listed. These manufacturers are listed for example purposes (unless followed by “No Exceptions”). The AV Contractor may substitute manufacturers and models that may be more cost effective or readily available than that specified. However, all substitutions shall meet or exceed the specified functional and technical requirements. Acceptance of such substitutions is at the discretion of the AV Consultant and the Architect.

1.07 RELATED WORK

- A. Provide in accordance with Section 27 41 00, General Conditions and Requirements for Audiovisual Systems
- B. Definitions
 1. The following shall serve as general identifiers as specified herein.
 - a. Regardless of their usage in codes or other industry standards, certain words or phrases as used in the Drawings or Specifications for the Work, shall be understood to have the specific meanings as ascribed to them in the following list:
 - 1) “Circuit” – Any specific run of circuitry
 - 2) “Circuitry” – Any Work which consists of wires, cables, raceways, and/or specialty wiring method assemblies complete with associated junction boxes, pull boxes, outlet boxes, joints, couplings, splices, and connections except where limited to a lesser meaning by specific description.
 - 3) “Concealed” (as applied to circuitry) – Covered completely by building materials, except for penetrations (by boxes and fittings) to a level flush with the surface as necessitated by functional or specified accessibility requirements.
 - 4) “Exposed” (as applied to circuitry) – Not covered in any way by building materials.
 - 5) “Normal Work Conditions” – Locations within building confines that are not damp, wet, or hazardous and that are not used for air handling.
 - 6) “Patch Panel” – A System of terminal blocks, patch cords, and backboards that facilitate administration of cross-connecting cables.
 - 7) “Raceway” – Any pipe, duct, extended enclosure, or conduit (as specified for a particular System) which is used to contain wires and which is of such nature as to require that the wires be installed by a “pulling in” procedure.
 - 8) “Riser” – Shall refer to the portion of the installation that transmits between building floors (or between Audio Visual Systems rooms), also referred to as “Backbone Cabling”.
 - 9) “AV System(s)” – Audio Visual System(s), includes all components contained herein that work in conjunction to create and completely integrated and fully functioning system as described within the Drawings and Specifications
 - 10) “Audio Visual Systems Wiring” – see “Circuitry”
 - 11) “Audio Visual Systems Work” – See “Work”
 - 12) “Standard” (as applied to wiring devices) – Not of a separately designated individual type.

- 13) “Subject to Mechanical Damage” – Exposed within 6 feet of the floor in mechanical rooms, manufacturing spaces, vehicular spaces, or other spaces where heavy items are moved around or rigged as a common practice or as required for replacement purposes.
 - 14) “System” – See “AV Systems”
 - 15) “Wiring” – see “Circuitry”
2. The following shall serve as general identifiers as specified herein.
- a. Owner – Joliet Junior College
 - b. Project Architect – DKA Associates
 - c. AV Consultant – Shen Milsom & Wilke, LLC.
 - d. AV Contractor – The Contractor is the firm submitting a proposal to furnish and install the Work as defined within this Specification.
 - e. Project – City Center
 - f. Work – The term “Work” means all construction and services specified within this document. The Work includes all related labor, materials, equipment, and services provided, or to be provided, by the Systems Contractor to fulfill the proposal’s obligations.
 - g. Drawings – The term “Drawings” means all Audio Visual Systems Drawings and associated sketches, details, riser diagrams, etc.
 - h. As used in the Drawings and Specifications for the Work, certain non-technical words and phrases shall be understood to have specific meanings as follows, regardless of indications to the contrary in the General Conditions or other documents governing the Work.
 - 1) “Furnish” – Purchase and deliver to the project site complete with every necessary appurtenance and support, all as part of the Audio Visual Systems Work. Purchasing shall include payment of all sales taxes and other surcharges as may be required to assure that purchased items are free of all liens, claims, or encumbrances.
 - 2) “Install” – Unload at the delivery point at the site and perform every operation necessary to establish secure mounting and correct operation at the proper location in the project, all as part of the Work.
 - 3) “New” – Manufactured within the past year and never before used.
 - 4) “Provide” – Furnish and Install.
 - i. Where the word “conduit” is used without specific reference to type, it shall be understood to mean “raceway”.
 - j. Reference to “U.L. (Materials Construction) Standards” shall mean the “Standards for Safety” published by Underwriters Laboratories, Inc.

1.08 GENERAL CONDITIONS - AUDIOVISUAL

- A. Work Experience Coordination and Compliance
1. The AV Contractor represents that they are familiar with, and have expertise in the Work of this nature and scope. The AV Contractor shall provide references for at least three (3) similar projects completed in the last five (5) years. Project Engineer shall have a minimum of CTS certification through Infocomm, or similar certification through Syn Aud Con or comparable certification. The AV Contractor further agrees that they shall provide all Work as may be required to make a complete job of that which may not be fully defined in the Programmatic Documents.
 2. The AV Contractor shall comply with all of the regulations, including safety regulations of national, city, local and other government agencies having jurisdiction concerning the work of the AV Contractor. The AV Contractor shall give all notices and comply with all laws, ordinances, codes, rules, and regulations bearing on the conduct of the Work. If the AV Contractor performs any work, which is contrary to such laws, ordinances, codes, rules and regulations, they shall make all changes for compliance and bear all associated costs.

3. The AV Contractor warrants that both they and their subcontractors are licensed as required by the authorities having jurisdiction and as required by local ordinances.
4. The AV Contractor must state if they intend to utilize a subcontractor, and provide said subcontractor's name and address. The subcontractor shall comply with all the same rules, regulations, laws and codes, licenses, etc. as required by the AV Contractor and as specified herein.
5. All of the AV Contractor's work shall be tested and inspected by all authorities having jurisdiction and in accordance with all Specifications. The AV Contractor shall coordinate and cooperate fully and shall provide, at no additional cost to the Owner, manpower, blueprints, facilities, scaffolds, etc. to reasonably assist the inspectors.
6. All permits required for any part of the AV Contractor's work shall be procured and paid for by the AV Contractor. The AV Contractor shall determine all permits required and transmit this information to the GC.
7. The Work called for under this Contract shall be carried on simultaneously with the Work of other trades in such a manner as to not delay the overall progress of the construction project. The AV Contractor is responsible for all coordination of the Work with other trades.
8. Include in the Work all necessary supervision and issuing of all coordination information to any other trades who are supplying work to accommodate the Audio Visual Systems installation.

B. Project Management

1. The Contractor shall provide a Project Manager to oversee and coordinate all activities on the Project
2. Project Manager's Duties and Responsibilities:
 - a. The Contractor shall provide to the Owner, as a part of the prefabrication submittal, the name of the Project Manager that will provide all duties and responsibilities as specified herein, during the term of the project.
 - b. The Project Manager shall maintain the ability of making all managerial decisions on behalf of the Contractor on a day-to-day basis, and shall retain the authority of accepting notices of deduction, inspection reports, payment schedules and any other project related correspondence on behalf of the owner.
 - c. The Project Manager shall schedule and attend project management meetings, during which time all System related issues are discussed, scheduled, confirmed, and/or resolved.
 - d. The Project Manager shall be available during normal business hours (800 hours to 1700 hours within two (2) hours by telephone during the term of the project.
 - 1) After normal business hours, the Project Manager shall be available within four (4) hours by telephone during the term of the project.
 - 2) In the event that the Project Manager is not available within the allotted time frame, the Contractor may designate another employee to temporarily act as the Project Manager in all correspondence with the Owner.
 - 3) The Contractor shall ensure that any individual temporarily assuming the duties of the Project Manager is at equal or higher level in the Contractor's managerial chain of command.
 - e. Upon notification by the Owner, of any project related installation issue, or issue that may contradict the Specifications as stated herein, the Project Manager shall respond to such issue, verbally and/or in writing within an eight (8) hour period
 - 1) Responses to such issues as stated above shall include a clear understanding of the issue, along with a tentative plan of action, reflecting milestones and/or deadlines to resolve the issue.
 - 2) Where appropriate, based on the overall importance of the project issue, the Project Manager shall follow-up their initial response with a written response to the issue within 24 hours of identification of the issue.

- f. Prior to the initiation of the Work, the Project Manager shall submit a schedule reflecting key milestones of the Work, including but not limited to the following:
 - 1) Bid award
 - 2) Kick-off meeting
 - 3) Plan submittal
 - 4) Prefabrication submittal
 - 5) Ordering, delivery, and installation of System equipment
 - 6) Field equipment delivery
 - 7) Project management schedule
 - 8) Payment schedule
 - 9) Installation completion date
 - 10) System training
 - 11) Delivery of As-Built documentation
 - 12) Delivery of Operations & Maintenance Manuals
 - 13) Final System test
 - 14) Acceptance of System
- g. The Project Manager shall update the schedule on a weekly basis to reflect the status of each key milestone as the Work progresses.
- h. As the System installation progresses, the Project Manager shall be capable of discussing any/or all of the above mentioned items at the request of the Owner, and shall address each item, as it relates to the current status of the Work.
- i. Project Schedule and Key Dates
- j. It is the responsibility of the contractor to coordinate their project schedule the General Contractor's Construction Schedule upon award of a contract. Refer to the Project cover documents for specific instructions to Bidders

C. Quality of Workmanship

- 1. The AV Contractor, upon receiving notice from the Architect that the AV Contractor has furnished inferior, improper or unsound work or materials (including equipment), or work or materials at variance with that which is specified, will, within 24 hours, proceed to remove such work or materials and make good all other work or materials damaged thereby, and, at the option of the Architect, the AV Contractor shall immediately replace such work or materials with work or materials as specified. The removal, replacement, and repair shall be performed at such times and with manpower sufficient, in the judgment of the Architect, so as to avoid disturbance to occupants, or other ongoing work for the Project.

D. On Site Storage

- 1. The AV Contractor shall be responsible for coordination and maintenance of a storage space.
- 2. If this storage space is required to be on-site it shall be the AV Contractor's responsibility to coordinate the size and spatial requirements with the GC.
- 3. The AV Contractor shall assume full responsibility for the storage space and all contents, unless otherwise indicated by the GC.
- 4. The AV Contractor shall examine the site and the Programmatic Documents and review with the GC the designated areas of access, delivery, and storage for the AV Contractor's use. The AV Contractor agrees that such areas are satisfactory and sufficient for their needs in the completion of their work and in conformance with the terms of this Contract.

E. Protection from Damage

1. The AV Contractor shall provide all protection necessary to safeguard their work from damage by their operations and the operations of others. Unless the AV Contractor proves to GC's satisfaction that the Work has been damaged by others, the AV Contractor shall promptly repair, adjust, and clean all defective installations and bear all associated costs.

F. Design Intent

1. The project documentation is, in general, diagrammatic and/or developed to communicate design intent. The AV Contractor shall coordinate the installation of all devices and/or equipment with the GC prior to installation based on the existing field conditions.
2. It shall be understood that the Specifications and Drawings are complementary. Where there are conflicts within the documents, the overall design intent shall govern.
3. To the extent that they govern the Work, the Program documents, Specifications and Drawings also govern change order Work, if any.
4. The Drawings for the Work utilize symbols and schematic diagrams that have no dimensional significance. The Work shall be installed to fulfill the diagrammatic intent expressed on the Drawings, field layouts, and shop drawings of all trades.
5. Certain details appear on the Drawings for the Work that are specified with regard to the dimensioning and positioning of the Work. These are intended only for general information purposes. They do not obviate field coordination for individual items of the indicated Work.
6. Information as to general construction and architectural general construction and architectural features and finishes shall be derived from the structural and architectural drawings and specifications, and may require ongoing coordination with the Architect.
7. Ratings of devices, materials, and equipment specified without reference to specific performance criteria shall be understood to be nominal or nameplate ratings established by means of industry standard procedures.
8. It is the intent of the Drawings and Specifications to provide complete operating AV Systems. All Work necessary to provide such a System shall be performed. Any discrepancies shall be brought to the AV Consultant's attention.

1.09 WARRANTY AND MAINTENANCE

- A. AV Systems Contractor shall provide a one (1) year warranty for the Work. The warranty shall cover all Work, Systems, and subsystems against defects in materials and workmanship. The Work as specified herein, including all materials and labor, but excepting any existing devices and equipment which are incorporated in the completed Work, shall be warranted to be free from defects in design, workmanship, and materials. Further, the AV Contractor shall warrant that the completed Systems, including all components (except those, which are existing or provided by others), are of sufficient size and capacity to fulfill the requirements of the Specifications.
- B. The warranty shall be valid for a period of one (1) year following the date of System acceptance by the Owner and the Architect. System acceptance shall commence when all parts, components, sub-Systems, and Systems have been tested, shown to be working in accordance with the Specification, and approved by the AV Consultant.

- C. In cases where the manufacturer's warranty period is greater than twelve months, the contractor must be prepared to honor that warranty for the full extent of the manufacturer's warranty period. This shall exclude any labor costs incurred by the contractor removing and re-installing the defective items.
- D. In cases where the manufacturer's warranty period is less than 12 months, the contractor is liable for defects in the item up to-but not exceeding-the first twelve-month period on any contractor provided items.
- E. To maintain certain manufacturer's warranties, said equipment must be installed, aligned and serviced by those installers authorized by said manufacturer to perform those duties. If the contractor is not authorized, by said manufacturer, it is his sole responsibility to make the appropriate arrangements and bear all cost and consequences thereof.
- F. All manufacturers' equipment warranties shall be activated in the Owner's name and shall commence on the date of system acceptance. In the case of AV Contractor-modified equipment, the manufacturer's warranty is normally voided. In such cases, the AV Contractor shall provide the Owner with a warranty equivalent to that of the original manufacturer.
- G. Warranty Service:
 - 1. In the event that defects in the materials and/or workmanship are identified during the warranty period, the AV Contractor shall provide all labor and materials as may be required for prompt correction of the defect.
 - 2. Provide written notice to the Owner documenting any Work performed during the warranty period, including any preventative maintenance Work performed.
 - 3. Provide loaner equipment that is fully compatible with the Audio Systems for any equipment not field repairable.
 - 4. Loaner equipment for components that must be shipped to/from the manufacturer or distributor shall be on site and operational within 48 hours of the component failure. Furnish lists of equipment that will require shipment from the manufacturer or distributor and lead times associated with that equipment.

1.10 SPECIAL CONSIDERATIONS

- A. Cable and Inner Duct Color:
 - 1. Cable color and Inner-Duct shall be black in areas where visible to the general public in front of house" spaces.
 - 2. In such cases where a particular cable meeting the environmental requirements of the space is to be installed and is not available in black, provide and install a suitable raceway in black. Example of this could optical fiber installed in black inner-duct.

PART 2 - PRODUCTS

2.00 27.41.16 – INTEGRATED AUDIOVISUAL SYSTEMS

- A. Functional Descriptions
 - 1. **CULINARY LABS:** The Culinary Labs are intended for instruction, demonstration and evaluation of students in an active preparation and cooking environment. Each lab includes at least one primary instructor's cooking station (OFE). Above each instructor's station are situated one or more PTZ cameras and in some spaces, one Fixed Lens camera. The cameras' point of view is adjusted using PTZ camera control with adjustable preset configurations in order to present a specific area of instruction

space or a specific culinary function. Individual camera images are transmitted to a central AV matrix switcher, located in AV Control Room 20023A. Control of this switcher enables the display of one or more of the camera images at specific video flat panel displays.

Control of the camera preset positions and the matrix mixer routing are controlled by iOS tablet control surfaces and a foot switch controller which will allow the instructor to select presets hands free.

In the larger culinary lab spaces, a wireless lapel microphone is provisioned for reinforcing the instructor's voice.

A video cue monitor display will also be installed on a dual display pole mount behind each of the student flat panel display monitors.

The audio and video signals from several culinary lab spaces can be routed to other culinary spaces, public spaces, etc. using the central AV matrix switcher.

Specifically in the Competition Lab, PTZ cameras will also be located above each student competition work area to allow the instructor/moderator to observe each competing student.

Each instructor station will also be provisioned with a local AV input connectivity panel, mounted in a recessed box in the station millwork. This panel will provide dual HDMI inputs. This will allow the instructor to use a mobile device (with adaptor), laptop PC, etc. and display those sources over the flat panel displays.

NOTE: It is the responsibility of the AV Contractor to coordinate exact locations of cameras, flat panel displays, input panels, tablet mounts, etc. with the Owner and the Architect.

The cameras' points of view are aimed using PTZ camera controls with adjustable preset configurations in order to present a specific area of instruction space or a specific culinary function. Individual camera images are transmitted to a central AV matrix switcher, located in AV Control Room 20023A. Control of this switcher enables the display of one or more of the camera images at specific video flat panel displays.

Control of the camera preset positions and the matrix mixer routing are controlled by touch control panels (in some cases), iOS tablet control surfaces and a foot switch controller which will allow the instructor to select presets hands free.

In the larger culinary lab spaces, a wireless lapel microphone is provisioned for reinforcing the instructor's voice.

A video cue monitor display will also be installed on a dual display pole mount behind each of the student flat panel display monitors.

The audio and video signals from several culinary lab spaces can be routed to other culinary spaces, public spaces, etc. using the central AV matrix switcher.

Specifically in the Competition Lab, PTZ cameras will also be located above each student competition work area to allow the instructor/moderator to observe each competing student.

Each instructor station will also be provisioned with a local AV input connectivity panel, mounted in a recessed box in the station millwork. This panel will provide dual HDMI inputs. This will allow the instructor to use a mobile device (with adaptor), laptop PC, etc. and display those sources over the flat panel displays.

The Meat Lab will be a scaled down AV space. A single Fixed Lens camera will be mounted on an articulating arm, allowing a wider range of adjustment during carving and meat prep demonstrations. This camera will be routed to a flat panel display, wall-mounted on the north wall of the lab.

2. **CLASSROOMS:** The Classrooms are intended for instruction, presentation and evaluation of students.
Each classroom includes one instructional lectern (OFE). Located in close proximity to the lectern is an AV connectivity panel, with dual HDMI inputs, which are directly routed to appropriate input connections at the video projector.
The video projector shall be a short throw projection device, wall mounted using the included arm mount.
The projected image will be displayed on a wall-mounted manual projection screen.
One pair of classrooms, Rooms 5006 & 5007 will provide the capability of combining AV inputs and projection displays when the operable divisible wall is open.
Control of the classrooms systems will be accomplished via the included manufacturer's handheld remote control.
3. **CHEF'S TABLE AND KITCHEN:** The Chef's Table and Kitchen are intended for demonstration events in an active preparation and cooking environment, as well as private dining and group dining.
The Chef's Kitchen is outfitted with two PTZ cameras mounted in strategic locations in order to provide an optimum camera view of all of the work surfaces that will be utilized by the Chef.
The cameras' points of view are aimed using PTZ camera controls with adjustable preset configurations in order to present a specific area of demonstration space or a specific culinary function. Individual camera images are transmitted to a central AV matrix switcher, located in AV Control Room 20023A. Control of this switcher enables the display of one or more of the camera images at specific video flat panel displays. Control of the camera preset positions and the matrix mixer routing are controlled by an iOS tablet control surface and a foot switch controller which will allow the instructor to select presets hands free.
In the larger culinary lab spaces, a wireless lapel microphone is provisioned for reinforcing the instructor's voice.
A video cue monitor display will also be installed on a display pole mount to enable the Chef to verify what is being displayed in the Chef's Table and other spaces viewing the event.
The audio and video signals from the Chef's Kitchen can be routed to other culinary spaces, public spaces, etc. using the central AV matrix switcher.
The Chef's Kitchen will also be provisioned with a local AV input connectivity panel, mounted in a recessed box in the station millwork. This panel will provide dual HDMI inputs. This will allow the instructor to use a mobile device (with adaptor), laptop PC, etc. and display those sources over the flat panel displays.
NOTE: It is the responsibility of the AV Contractor to coordinate exact locations of cameras, flat panel displays, input panels, control panels/tablet mounts, etc. with the Owner and the Architect.
4. **STUDENT DINING AND SERVERY:** The Student Dining and Servery are primarily intended as its name suggest. The Student Dining space will also provide viewing of remote live content from various culinary spaces including the adjacent Competition Lab. In addition, a local AV input connectivity panel will provide both HDMI and VGA inputs.
The Student Dining space is outfitted with a ceiling mounted video projector and a recessed ceiling mount electric projection screen.
The case of the electric projection screen will be installed by the GC. The internal screen and roller assembly will be installed by the AV Contractor after the space is "clean" from dust and other construction debris and general construction has been completed.

Ceiling mounted loudspeakers in the Student Dining and Student Servery will reinforce audio from the video content, as well as background music as provided by portable audio playback devices, connected to the audio inputs associated with the VGA source input

Control of the video projector (including source input selection) will be accomplished using the included handheld wireless remote control.

Control of the projection screen will be accomplished via the wall-mounted key switch panel.

5. **COMPETITION LAB:** The Competition Lab is intended to support culinary competitions, both local, regional and nationally in an active preparation and cooking environment, as well as providing an environment for JJC students to demonstrate their culinary educational accomplishments. These demonstrations may be viewed by campus students and faculty as well as student families and friends, and potential employers. The Competition Lab includes at least one primary instructor's cooking station (OFE). Above each instructor's station are situated one or more PTZ cameras. The cameras' point of view is adjusted using PTZ camera control with adjustable preset configurations in order to present a specific area of instruction space or a specific culinary function. Individual camera images are transmitted to a central AV matrix switcher, located in AV Control Room 20023A. Control of this switcher enables the display of one or more of the camera images at specific video flat panel displays.

Control of the camera preset positions and the matrix mixer routing are controlled by iOS tablet control surfaces and a foot switch controller which will allow the instructor to select presets hands free.

A wireless lapel microphone system is provisioned for reinforcing the instructor's voice to both participating students and those observing from the Student Dining area and other remote culinary spaces.

A video cue monitor display will also be installed on a display pole mount.

The audio and video signals from the Competition Lab can be routed to other culinary spaces, public spaces, etc. using the central AV matrix switcher.

Specifically in the Competition Lab, PTZ cameras will also be located above each student competition work area to allow the instructor/moderator to observe each competing student.

The instructor station will also be provisioned with a local AV input connectivity panel. This panel will allow both HDMI and VGA with stereo audio signal inputs. This will allow the instructor to use a mobile device (with adaptor), laptop PC, etc. and display those sources over the video projection system.

NOTE: It is the responsibility of the AV Contractor to coordinate exact locations of cameras, flat panel displays, input panels, control panels/tablet mounts, etc. with the Owner and the Architect.

The cameras' points of view are aimed using PTZ camera controls with adjustable preset configurations in order to present a specific area of instruction space or a specific culinary function. Individual camera images are transmitted to a central AV matrix switcher, located in AV Control Room 2003A. Control of this switcher enables the display of one camera image at the video projection screen and other remote video displays.

6. **GENERAL PUBLIC SPACES:** The General Public Spaces AV systems are intended to support various spaces including the Lobby, Lounges (future), Elevators (first floor Day One), Group Study rooms, Tutoring space, etc. Each of these spaces is outfitted with video displays, either video projection or flat panel display. In some spaces a local AV input connectivity panel is included to provision users to connect mobile devices such as tablets, laptops, document cameras, etc.

7. **ADMINISTRATION SPACES:** The AV systems in the Administration Spaces will support: Front Desk viewing using two video displays as a part of the security system. The AV Contractor shall provide and install these two displays with appropriate wall mounts. An adjacent IP connectivity panel will allow these displays to connect to the security system (provided by others).

Testing Center viewing, using two video displays, will be provided for administrative staff to monitor students in testing sessions. The AV Contractor shall provide and install the two displays with appropriate wall mounts. Adjacent IP connectivity panels will allow these displays to connect to the testing center cameras, as controlled by the security systems (provided by others).

The Reception space and the Student Support Office area (corridor 3017) flat panel displays will view source inputs at an AV connectivity panel in an adjacent space. This display and others within the administration spaces will also be able to view digital signage and IPTV channels (see Custom Quotes and Alternates tab in the Equipment List).

The primary Conference Room will be outfitted with a flat panel display and local AV connectivity via an AV floor box that will include AV input panels, data panels and AC power. This display will also be able to view digital signage and IPTV channels (see Custom Quotes and Alternates tab in the Equipment List).

8. **Portable Equipment Pool:** The Portable AV Equipment Pool provides an initial inventory of assisted listening system and wireless microphone systems as required by ADA.

B. System Interconnections

1. The functional interconnections of the audio, video and control systems shall be as detailed on drawings.

The Contractor shall provide all interconnection cable, connectors, terminal strips, wireways, flexible conduit, etc., to facilitate the audiovisual systems as detailed within these specifications and drawings.

The conduit and power systems are detailed in the Electrical Engineer's drawings.

C. System Equipment & Components

1. The audiovisual hardware for all major components shall be provided based upon the manufacturer and model numbers as listed in Appendix 'A' of this specification. The equipment manufacturer and models shall be considered a minimum performance standard for all physical, functional, performance and all warranty/support specification, as listed by the manufacturer, and shall be used as a benchmark for any proposed alternates or substitutions as allowed through other parts of this specification document.
2. Appendix 'A' shall address these performance requirements by space-type and application, as divided into Control, Display & Video, Audio, and Miscellaneous type products. Lack of a listed, desired or necessary component, accessory, option or other criteria shall not absolve the Bidder from providing a complete turnkey system as identified in other parts of this specification document.
3. Bidder shall refer to Appendix 'A' for all specific product information, and submit product and pricing as noted in other parts of this specification.

2.01 EQUIPMENT LAYOUT

- A. The equipment in this facility shall be as detailed on drawings.

2.02 OWNER FURNISHED EQUIPMENT

- A. All room furniture will be furnished by the Owner (except as listed above), including countertops, tables and portable work surfaces, and instructional lecterns.

- B. PC computers/laptops.

2.03 RELATED WORK SPECIFIED ELSEWHERE

- A. The following systems and equipment are not provided under this contract. The Contractor is to coordinate with the base bid contractors as necessary to insure compatibility.
 - 1. Telecommunication networks and systems
 - 2. Installation of recessed projector casings (installed by General Contractor)
 - 3. Loudspeaker back cans for gypsum ceilings to be purchased by AV Contractor and installed by the Electrical Contractor
 - 4. All building electrical circuits required for AV system power and associated device power.
 - 5. FF&E millwork, etc.

PART 3 - EXECUTION

3.00 EXAMINATION

- A. Verification of Conditions: Examine the areas to receive the work and the conditions under which the Work would be performed. AV Contractor shall remedy conditions detrimental to the proper and timely completion of the Work. Do not proceed until unsatisfactory conditions have been corrected.

3.01 INSTALLATION

- A. General
 - 1. All installation practices shall be in accordance with, but not limited to, these specifications and drawings. Installation shall be performed in accordance with the applicable standards, requirements, and recommendations of National and Local authorities having jurisdiction.
 - 2. If, in the opinion of the AV Contractor, an installation practice is desired or required, which is contrary to these specifications or drawings, a written request for modification shall be made to the AV Consultant. Modifications shall not commence without written approval from the AV Consultant. Every effort will be made to respond to all written requests, in a timely manner, as to not delay the installation or completion of the project.
 - 3. Prior to ordering equipment, the AV Contractor shall coordinate the frequencies of all wireless devices to prevent unwanted interaction between devices and rooms. This includes, but is not limited to, wireless microphones, assisted listening system devices, wireless control panels, etc.
 - 4. All accessories, including rack mounting hardware, power supplies, etc., shall be obtained from the original equipment manufacturer. Unless otherwise noted or specified, third party accessories shall not be used.
 - 5. All installation practices shall be in accordance with, but not limited to, these specifications and drawings. Installation shall be performed in accordance with the applicable standards, requirements, and recommendations of National and Local authorities having jurisdiction.
 - 6. If, in the opinion of the AV Contractor, an installation practice is desired or required, which is contrary to these specifications or drawings, a written request for modification shall be made to the AV Consultant. Modifications shall not commence without written approval from the AV Consultant. Every effort will be made to respond to all written requests, in a timely manner, as to not delay the installation or completion of the project.

7. During the installation, and up to the date of final acceptance, the AV Contractor shall be under obligation to protect his finished and unfinished work against damage and loss. In the event of such damage or loss, the damage shall be replaced or repaired at no cost to the Owner.

B. Physical Installation

1. All equipment shall be firmly secured in place unless requirements of portability dictate otherwise.
2. Fastenings and supports shall be adequate to support their loads with a safety factor of at least five. All boxes, equipment, etc., shall be secured plumb and square.
3. Audiovisual Contractor shall provide and install appropriate safety cabling for loudspeaker components.
4. In the installation of equipment and cable, consideration shall be given not only to operational efficiency, but also to overall aesthetic factors.
5. All loudspeakers shall be installed so that minimum clearances between loudspeakers and proscenium walls are maintained, per AV system detail drawings, without sacrificing horizontal coverage areas.

C. Trim and Escutcheon Components

1. To insure a proper finished appearance, the AV Contractor shall furnish and install trim/escutcheon components at all conditions where A/V components pass through the finished ceilings. This would include but not be limited to video projector supports, flat-panel display supports and any other component which is not specifically supplied with integral flanges/trim components; i.e. speaker mounts, assistance listening devices, etc.
2. All trim components at the ceiling plane shall be finished to match the approved ACT ceiling grid system components. The audiovisual contractor should obtain a sample from the General Contractor, including any custom color information, or standard color numbers. All trim components shall be submitted to the Architect for review and approval prior to fabrication.

D. Mounting

1. All equipment shall be firmly secured in place unless requirements of portability dictate otherwise.
2. Fastenings and supports shall be adequate to support their loads with a safety factor of at least five (5). All boxes, equipment, etc., shall be secured plumb and square.
3. All displays and video projectors must have security cables attached to the building structure or other approved methods to assist in the prevention of loss.
4. Other equipment, not designated as 'Portable' shall be provided with security fasteners, secured to furniture, or otherwise secured, using approved methods or materials as described in the Contract Documents

E. Cable Installation

1. All wire bundles are to be neat and combed free of cable crossovers.
2. All cables, regardless of length, shall be marked with a permanent, self-laminating wrap-around number or letter cable marker at both ends, similar to the Panduit "Pan-Code" system. Labels must be computer-generated for legibility. Wire labels done by hand in the field must be replaced with computer generated labels. There shall be no unmarked cables at any place in the system. Marking codes used on cables shall correspond to codes shown on drawings and or run sheets.

3. All cables shall be grouped according to the signals being carried. In order to reduce signal contamination, separate groups shall be formed for the following cable families:
 - a. Power cables
 - b. Control cables
 - c. Video cables
 - d. Audio cables carrying signals less than – 20 dBm
 - e. Audio cables carrying signals between – 20 dBm and +20 dBm
 - f. Audio cables carrying signals above +20 dBm
4. As a general practice, all power cables, control cables, and high level cables shall be run on the left side of an equipment rack as viewed from the rear. All other cables shall be run on the right side of an equipment rack, as viewed from the rear.
5. Cables ties shall be placed at appropriate intervals of no greater than six inches for vertical bundles, two inches for horizontal bundles.
6. All vertical cable bundles shall be attached to the rack frame.

F. Wire Terminations

1. All cables shall be continuous lengths without splices.
2. All system wire, after being cut and stripped, shall have the wire strands twisted back to their original lay and be terminated by approved soldered or mechanical means.
3. Except where noted otherwise in the specifications, NO BARE WIRE TERMINATIONS WILL BE ACCEPTED. Heat-shrink tubing shall be used to insulate the ground or drain wire.
4. Unused wires at the end of a cable shall remain unstripped and shall be laid back and held in place with wire ties.
5. All solder connections shall be made with rosin-core solder using temperature-controlled solder stations. Care shall be taken to avoid cold or cracked solder joints. Any connections that do not appear to be clean and shiny, or which show signs of cracking, shall be re-soldered by the contractor before final acceptance of the system.
6. Mechanical connections using insulated, crimp-type connectors shall be bonded to the connector by soldering the wire to the metal part of the connector.
7. Connections made with screw actuated pressure type terminal strips shall be made by stripping approximately 1/4 inch of insulation from the stranded conductor. Then the un-tinned wire shall be inserted into the terminal and the screw tightened using a secure fitting precision screwdriver.
8. Terminal blocks, boards, strips or connectors shall be furnished for all cables which interface with racks, cabinets, consoles, or equipment modules.

G. Cable – Rack/Termination Points

1. Cable separation/routing:
 - a. All power cables, control cables, and high level cables shall be run on the left side of an equipment rack as viewed from the rear.
 - b. All other cables shall be run on the right side of an equipment rack, as viewed from the rear.
2. All cable entry shall be through the tops of racks or through entrance holes in the base of the rack. No cable shall enter racks through front, rear or side panel openings
3. Cables shall not protrude from the back of racks.
4. Cables ties shall be placed at appropriate intervals of no greater than six inches for vertical bundles, two inches for horizontal bundles.
5. All vertical cable bundles shall be attached to the rack frame.

6. For equipment mounted in drawers or on slides, the interconnecting cables shall be provided with a service loop of appropriate length
7. All cable entry shall be through the tops of racks or through entrance holes in the base of the rack. No cable shall enter racks through front, rear or side panel openings
8. All system wire, after being cut and stripped, shall have the wire strands twisted back to their original lay and be terminated by approved soldered or mechanical means.
9. Except where noted otherwise in the specifications, NO BARE WIRE TERMINATIONS WILL BE ACCEPTED.
10. Heat-shrink tubing shall be used to insulate the ground or drain wire.
11. Unused wires at the end of a cable shall remain unstripped and shall be laid back and held in place with wire ties.
12. All solder connections shall be made with rosin-core solder using temperature-controlled solder stations.
13. Care shall be taken to avoid cold or cracked solder joints. Any connections that do not appear to be clean and shiny, or which show signs of cracking, shall be resoldered by the Installing Contractor before acceptance of the system.
14. Mechanical connections using insulated, crimp-type connectors shall be bonded to the connector by soldering the wire to the metal part of the connector.
15. Connections made with screw actuated pressure type terminal strips shall be made by stripping approximately 1/4 inch of insulation from the stranded conductor. Then the un-tinned wire shall be inserted into the terminal and the screw tightened using a secure fitting precision screwdriver
16. Terminal blocks, boards, strips, or connectors shall be furnished for all cables which interface with racks, cabinets, consoles, or equipment modules.
17. All cables shall have proper connector housing.

H. Cable – Labeling

1. All cables, regardless of length, shall be marked with a permanent, self-laminating wrap-around number or letter cable marker at both ends, similar to the Brady and Panduit products for laser/ink-jet printers, and handheld thermal printers.
 - a. Labels must be computer-generated for legibility.
 - b. Wire labels done by hand in the field must be replaced with computer generated labels.
 - c. There shall be no unmarked cables at any place in the system.
 - d. Marking codes used on cables shall correspond to codes shown on drawings and or run sheets.
 - e. All wire markers shall face a common direction.

I. Connector Plate Receptacles

1. Audio (microphone or line level) – XLR, locking type.
2. Audio (line level—Mono or Stereo) – 1/4" jack, locking type Jack shall be insulated from panel type
3. Audio (loudspeaker level) – lockable loudspeaker panel mount connector Type.
4. Audio (multi-pin analog mic/line level) – 61 pin circular bayonet type – Jack shall be insulated from panel type.
5. Intercom Panels – XLR type.
6. Video – BNC type.

7. VGA – DB-15HD jack, isolated from panel type, with hex nuts.
 8. RF (CCTV/CATV) – “F” type. Receptacles shall be insulated from panel type.
 9. RF (Wireless Antennae) – BNC type, 75 or 50 Ohm, as required. Receptacles shall be insulated from panel type.
 10. Digital Audio Snake/UTP transmission – RJ-45 type.
 11. Note: All connectors on wall plates, or in other exposed locations, are to be recessed.
- J. Grounding – In order to minimize problems resulting from improper grounding, and to achieve maximum signal-to-noise ratios, the following grounding procedures shall be adhered to:
1. System Grounds:
 - a. A single primary “system ground” shall be established for the systems in each particular area. All grounding conductors in that area shall connect to this primary system ground.
 - b. The system ground shall be provided in the audio equipment rack for the area, and shall consist of a copper bar of sufficient size to accommodate all secondary ground conductors.
 - c. A copper conductor having a maximum of 0.1 Ohms total resistance shall connect the primary system ground bar to the nearest approved electrical ground.
 - d. Secondary system grounding conductors shall be provided from all racks, audio consoles, and grounding point for the area. Each of these grounding conductors shall have a maximum of 0.1 Ohms total resistance.
 - e. Under no conditions shall the AC neutral conductor, either in the power panel or in a receptacle outlet, be used for a system ground
 2. No metallic conduit will terminate into the rack cabinet.
 3. Audio Cable Shields
 - a. All audio cable shields shall be grounded at one point only. There are no exceptions.
 - b. For inter and intra-rack wiring, this requires that the shield be connected at one end only.
 - c. For ungrounded portable equipment, such as microphones, the shield shall be connected at both ends but grounded at only one end.
 4. Video Receptacles
 - a. All video receptacles that are provided and installed by the Installing Contractor shall be insulated from the mounting panel, outlet box, or wireway. Unless otherwise detailed herein, this shall be accomplished by using insulated-from-panel type receptacles.
 5. Audio Receptacles
 - a. All audio receptacles that are provided and installed by the Installing Contractor shall be insulated from the mounting panel, outlet box, or wireway. Unless otherwise detailed herein, this shall be accomplished by using insulated-from-panel type receptacles.
 6. Caution
 - a. Because of the great number of possible variations in grounding systems, it shall be the responsibility of the Installing Contractor to follow good engineering practices.
- K. Cable Management
1. All wire markers shall face a common direction.
 2. All cables shall have proper connector housing.
 3. Cables shall not protrude from the back of racks.

4. All cable entry shall be through the tops of racks or through entrance holes in the base of the rack. No cable shall enter racks through front, rear or side panel openings.
5. Cables running in plenum areas without conduit shall be plenum rated cable, and match the specified cable above. It is the responsibility of the Bidder to inspect the electrical drawings, and verify in what spaces plenum cable shall be used. No claims for additional monies, based on the use of plenum cable, will be allowed.
6. All cables shall be cut to the length dictated by the run. No splices shall be permitted in any pull boxes without prior permission of the AV Consultant. For equipment mounted in drawers or on slides, the interconnecting cables shall be provided with a service loop of appropriate length.
7. No cable shall be installed with a bend radius less than that recommended by the cable manufacturer.
8. Where cables are installed in architectural niches, ensure that the cables are black, unless otherwise directed, to reduce visibility from the audience.
9. Where cables are installed that is visible, the cables will be sheathed in a color wrap that has been pre-approved for the location.

3.02 CONTRACTOR SYSTEM CHECKOUT

- A. Staging Checkout (Prototype Shop Checkout)
 1. Staging of systems and equipment at the Installing Contractors shop will be done to expedite the on-site installation by allowing the assembly and checkout where the resources are, and prior to the project site being ready.
 2. This applies to “one-off” AV system projects
 3. Prototypical system testing for proof of concept in projects with multiple like systems. This will allow the identification and prevention of making the same mistake multiple times.
 4. Installing Contractor will successfully perform, document, and then submit all the test results to the Owner
 5. Installing Contractor’s test submittal will serve to allow 7-days for the Owner to make arrangements to do Staging Checkout verification
 6. All verification testing is the responsibility of the Installing Contractor. This includes qualified personnel and proper test equipment.
 7. See related paragraphs entitled Performance Standards and Test Procedures for more details on testing and testing procedures
 8. In the event there is required rework, large scale readjustments, or defective equipment that must be repaired or replaced, tests may be suspended or continued at the option of the Owner.
 9. In the event there is required rework, large scale readjustments, or defective equipment that must be repaired or replaced, tests may be suspended or continued at the option of the Owner. Any charge for additional time incurred by the Consultant, or Owner, required to over-see the system tests, due to improper system installation or previous failed systems, shall be the responsibility of, and charged directly to the Installing Contractor.
 10. Checkout will include:
 - a. Appropriate Testing with as many of the various inputs and outputs that can be used to emulate the full system operation
 - b. Insure there are no equipment problems
 - c. Test as much of the control system operation as possible and to make sure the user interface is intuitive
 11. Inspection

- a. Workmanship
- b. Safety related issues
- c. Serviceability of the system

B. Staging Checkout Details:

1. All the equipment can be pulled for repairs or replacement without hindrance, equipment without IEC removable power cords are not tie-wrapped to the cabinet, and there are no obstructions to the item being pulled from the front of the rack. Further, terminations are such that it is relatively easy to find their proper terminating points when the item is re-installed.
2. If there are obstructions prohibiting the disconnection of terminations on the back of the unit, there must be sufficient cabling to permit the equipment to be pulled from the front, and disconnected there.
3. All cables are identified in a consistent, permanent, non-slipping manner, and all cable identification tags are visible (not hidden in forms). All cables have clearly legible, unambiguous identifying labels, and labels are oriented and positioned consistently.
4. Tie wraps are not too tight as to deform the cable. UTP cables are formed with Velcro ties.
5. Terminations are free from stress due to gravity acting on the form.
6. Terminations have sufficient service loop, allowing a re-termination or two without having to open a form to lay in a new cable.
7. Cable supports are used when unsupported cable lengths exceed 12 inches (depending on size and stiffness of cables).
8. Screw terminals have spade or ring lugs on wires.
9. Cables have "signal separation"; that is, cables carrying voltages varying by 20 dB or more are in different forms separated by at least 4 inches to prevent cross talk.
10. RJ terminations are solid in their connectors.
11. Coax cables respect a bend radius of at least 5x the cable's radii, or as recommend by the manufacturer.
12. All unbalanced and balanced terminations are in agreement with the equipment manufacturer's recommendations.
13. There is perfect agreement between the "paper model" documentation (drawings), the control system user interface (i.e., touch panel screens, push button labels, panel engravings, etc.), the device labels, any patch panels/designation strips, the physical wiring and labeling, and any label associated with the system.
14. All inputs and outputs of switchers are labeled (wherever possible), so that users can easily make manual routes quickly, without having to refer to the system drawings.
15. All channels on amplifiers, especially on multi-channel amplifiers are properly labeled, so users can make quick adjustments without having to refer to the system drawings.
16. All equipment in the rack is labeled, and the labels match those on the drawings (equipment symbols and/or description). This will allow for easy serviceability, as well as prevent confusion in systems with multiples of similar equipment.
17. All connectors on input and output plates are identified in a discernible, consistent manner (i.e., there is only one "MIC 1" in the system), and in agreement with all other labels in the system.
18. In short, equipment must be able to be serviced indefinitely; designed with the maintenance technician in mind (he or she will "own it" longer than the person who fabricated the system initially). Follow Giddings and Davis for specific details.

19. List all equipment in the system NOT present, and why.
20. Racks have temporary labels indicating the building and room where they are being installed.
21. I/O Panels are easily accessible.
22. All equipment installed. All mounts for all rack and field equipment (rack mounts, ceiling mounts, wall mounts, loudspeaker mounts, etc.) have been verified and tested.
23. Racks are "clean" - grease markings removed, etc.
24. All blanks installed.
25. All engravings fastened.
26. ALL Peripheral equipment hooked up as per flow diagram: microphones, loudspeakers, video monitors, projectors, PC's, USB switchers, etc.
27. Audio Tested (all lines marked).
28. Video tested (all lines marked).
29. The display is able to switch between different color spaces and resolutions. Show a Blu-ray or TV (YUV) signal, then show a laptop (RGB) signal, and then switch back to the Blu-ray/TV (YUV) signal. The source should always display properly.
30. Automatic CEC controls do not negatively affect the displays. With the displays powered on, power off each source in the system. The displays should remain on (no Power Off command sent from a source).
31. All sources can be routed to all expected destinations. Disregard any routes that are not permitted by design, as described in the narrative, such as HDCP sources routed to a codec.
32. All HDCP sources can be routed to all expected destinations at the same time. There are some devices with a limited capability to display on multiple displays. The system requires that each source can display on the required number of displays in the system at the same time.
33. For HDMI signals, test using the entire cabling to be installed in the field, to the extent it is possible. Using an HDMI generator, display pixel on/pixel off, with HDCP enabled, for the following resolutions: 1920x1200@60, 1920x1080@60, 1600x1200@60, 1280x720@60, 1280x768@60, 1280x800@60, 1024x768@60, 800x600@60, 640x480@60 (base default, in case the PC has issues and boots up in default mode). Inspect each, leaving the signal on for several seconds (no "sparklies") – HDMI Generator required.
34. Perform "Repeater Test" with HDMI tester. Requires connecting the tester at a source and sink location. Use the expected lengths of cable and any transmitters and receivers in the signal chain. Test will check that the repeater can pass signals up to 1080P. QD 780 Analyzer required.
35. Perform all "Source Tests" with HDMI tester on each source, especially Format Analyzer, Video Display, Audio Analyzer, and HDCP Tests immediately before all the sinks (displays) in the system. Test will verify source integrity and EDID information. QD 780 Analyzer required.
36. Perform "Sink Test" with HDMI tester on each display. Test will verify display can handle various resolutions, and spot check EDID to make sure they work with all sources. QD 780 Analyzer required.
37. If the switcher makes available a system status report with information regarding each source and destination signal integrity, EDID and CEC status information, etc., then obtain a report. If a printed or pdf report is not included, take a screen print showing the status of the system (including source and destination communications with the switcher) and include it in the Report.

38. When testing Blu-ray, confirm that the movie plays. Sometimes HDCP is not enabled during the menus and previews, but only during the movie.
 39. Confirm typical client laptops have been successfully used with the system, inclusive of default resolution (works with switcher EDID), any adapters, etc. Client laptop(s) required.
 40. Control tested (all lines marked - emulate closures for screens, motors, etc.)
 41. IP information provided by client and loaded into system, including IP address, network ID's, subnet masks, default gateway, timeserver, Gatekeeper, alias, hostnames, etc. These settings are listed in a report that will remain with the system.
 42. Any web-based system control or monitoring features, and other IP functionality of system (time servers, system-generated e-mail, etc.) thoroughly tested.
 43. All serial controlled equipment properly configured and communications established.
 44. All programming installed (control system, DSP devices), and properly communicating with the equipment intended. If a control specification is present, it has been thoroughly tested.
 45. When system is powered down, system "up" sequence presents the system in a desirable state with no objectionable anomalies.
 46. Thermal gradient inspected; all equipment operating within manufacturers' guidelines.
 47. THD < __ (0.5)%? Record results for all sources.
 48. S/N > __ (60) dB? Record results for all sources.
 49. Video levels 1 v P-P +/- 10%? (or 700 mV for computer video) for all sources.
 50. Inspect camera(s) image quality.
 51. Verify that there are no lost or stuck "on" pixels when Full White Test signal is displayed (7 pixels maximum per quadrant, or follow manufacturer's spec). Note number and location of lost pixels, if any.
 52. Small racks installed into credenzas have carpet tiles or sliders on bottom to avoid scratching credenzas.
 53. Confirm control system functions not obvious from the control flow diagrams (i.e., lighting presets that are activated when the control system enters a videoconferencing mode).
 54. Video – record or photograph any non-conformances, anomalies, etc.
 55. Sanity Check: Is there any reason why this system should NOT be released for installation? Is everything plumb and square, clean and blemish-free?
 56. Does the system under test satisfy ALL of the system requirements laid out in the client-approved functional narrative/signed proposal?
 57. Prepare document report, certifying the product, performance, and practices are in compliance, and noting any exceptions below. Distribute accordingly.
- C. Once successful completion of the Staging Checkout has been acknowledged the Installing Contractor can:
1. for "One-Off" Type of System – Prepare or proceed to the next phase of the installation
 2. for Prototypical – continue the assembly of the other like rooms while testing, documenting and submitting results for each system.
- D. On-Site Prototype Checkout
1. Prototypical system testing for proof of concept in projects with multiple like systems. This will allow the identification and prevention of making the same mistake multiple times.

2. Installing Contractor will successfully perform, document, and then submit all the test results to the Owner. Installing Contractor's test submittal will serve to allow 7-days for the Owner to make arrangements to do On-Site Prototype Checkout verification
 - a. All verification testing is the responsibility of the Installing Contractor. This includes qualified personnel and proper test equipment.
 - b. AV Consultant will be responsible to note any minor infractions on a "punch list" and Installing Contractor will be responsible for fixing these items before next checkout phase.
 - c. In the event there is required rework, large scale readjustments, or defective equipment that must be repaired or replaced, tests may be suspended or continued at the option of the Owner. Any charge for additional time incurred by the Consultant required to over-see the system tests, due to improper system installation or previous failed systems, shall be the responsibility of, and charged directly to the Installing Contractor
 3. Checkout will include:
 - a. Appropriate Testing with all field cables and connections made, and all equipment operational.
 - b. Insure there are no equipment and field wire problems
 - c. Test the complete control system operation and to make sure the user interface is intuitive
 - d. Inspection
- E. Procedure
1. Before Acceptance Tests are scheduled, the AV Contractor shall perform his own system check-out. He shall furnish all required test equipment and shall perform all work necessary to determine and/or modify performance of the system to meet the requirements of this specification.
 2. At the conclusion of the tests, return all equipment settings to previously calibrated positions.
 3. Provide written records of all test results in spreadsheet form.
 4. Check all control functions, from all controlling devices to all controlled devices, for proper operations.
 5. Adjust, balance, and align all equipment for optimum quality and to meet the manufacturer's published specifications. Establish and mark normal settings for all level controls, and record these settings in the "System Operation and Maintenance Manual".
 6. Maintain documentation of all performance tests for reference by the AV Consultant during the System Acceptance Tests.
- F. On Site Checkout Details:
1. Inspect and verify that all exceptions from the "Staging" checklist have been successfully completed.
 2. Record all equipment not present, and why.
 3. Have no stray AC voltages on any equipment accessible to a user relative to ground.
 4. Have no sharp or jagged surfaces accessible to a user.
 5. Thermal gradient inspected; all equipment operating within manufacturers' guidelines.
 6. Cable inspection: labeling, cable dress, signal separation, cable stress, serviceability, tie wraps too tight (none on Category cable, only Velcro ties). Cable labeling is positioned and oriented in a consistent manner, are legible and unambiguous.

7. Be complete. Demonstrate the full inventory to be all new equipment, in full compliance with the specification, or as modified by approved submission. Record test results as pass/fail, and list exceptions.
8. Confirm rack elevation and flow drawings, cable and other labels and engravings are an accurate paper model of the furnished system, and in compliance with latest revised specifications. Record test results as pass/fail.
9. All inputs and outputs of switchers are labeled (wherever possible), so that users can easily make manual routes quickly, without having to refer to the system drawings.
10. All channels on amplifiers, especially on multi-channel amplifiers are properly labeled, so users can make quick adjustments without having to refer to the system drawings.
11. All equipment in the rack is labeled, and the labels match those on the drawings (equipment symbols and/or description), control system, field plates, patch panels, and any labels associated with the system. This will allow for easy serviceability, as well as prevent confusion in systems with multiples of similar equipment.
12. RJ terminations are solid in their connectors.
13. Coax cables respect a bend radius of at least 5x the cable's radii, or as recommended by the manufacturer.
14. Record ambient noise, A-weighted, slow.
15. No power amplifier shall have its rated load exceeded. Record the impedance (and at what frequency) of each loudspeaker line on each power amplifier. 63, 250, and 1,000 Hz are recommended if available. ("Loudspeaker Impedance Test").
16. Produce a nominal operating level of __ (65) dB SPL (Sound Pressure Level) for conference speech, __ (60) dB SPL for program material, "A" weighted at all listeners' ears +/- __ (2) dB ("Uniformity of Coverage") (or at least __ (15) dB above the ambient noise, A-weighted, whichever is greater), with the control system volume control indicating "normal" or default setting. Record results for each channel and source.
17. Be capable of producing an additional __ (15) dB above this level (__ (80) dB SPL) for each audio source, with less than 0.5% THD (Total Harmonic Distortion) plus noise. Measure THD plus noise when source is at __ (15) dB above nominal operating level at each "destination", for all sources selected.
18. Develop a noise level that is electrically __ (55) dB below the normal operating level for all audio sources. "Noise" refers to hum, electrostatic noise, RF interference, etc. Measure and record Signal to Noise ("signal" measured electrically at nominal operating level at each destination, for all sources selected.)
19. Program loudspeakers shall be connected in the same polarity, and speech reinforcement systems shall be polarized such that a positive acoustic pressure on a microphone results in a positive acoustic pressure at the loudspeaker ("Polarity Test").
20. Produce no more than a __ (1) dB variance in program source levels, when each program source is playing a calibrated media (CD, video tape, setup test tone, etc.).
21. There shall be no audible vibration caused by improper mechanical installation. Use continuous sweep signal at headroom level (from generator or test CD) pass/ fail result or which device at what frequencies. ("Buzzes and Rattles Test").
22. The speech reinforcement system shall be stable (no feedback).
23. Equalizers shall be adjusted for best intelligibility, and in accordance with the preferred acoustic level response curves. (For installations with equalizers) Record the "house curve" before equalization, as well as after the equalizers have been tuned, with and without microphone input filters. If requested by the Consultant, produce this documentation for systems without equalizers, as this test may apply to the preamp filter settings in cases where intelligibility can be improved.

24. Be intelligible, with a RSTI (Rapid Speech Transmission Index) greater than 0.85. (If requested only) RSTI, using TEF, Smaart® Tools, or STI-PA. For systems where early reflections may cause intelligibility problems, or when multiple drivers are used, an ETC (Energy Time Curve) may be requested.
25. For wireless microphone systems, with all wireless microphones turned on, confirm that throughout the specified operating area for the transmitter, there are no dropouts, intermodulation interaction between wireless systems, or RF caused artifacts. Also confirm that there is little or no RF activity on a receiver's "S" meter when the designated microphone transmitter is off.
26. Confirm RF immunity at areas where users are expected to operate cell phones and messaging PDA's, smartphones, etc.
27. For NTSC sources, placing a test generator at each source shall produce 1 volt peak-to-peak to each destination +/- 10% (or 1dB). (If requested only) record results at each destination using NTSC bars, peak white, and 5-step multiburst (0.5, 1.0, 2.0, 3.0, 3.58, and 4.2 MHz).
28. Also for NTSC sources, confirm optimum brightness, contrast, and color in displays using SMPTE source with PLUGE (Picture Line Up Generation Equipment) display.
29. When several displays are visible in the same space, demonstrate consistencies in colors across all of them. For composite video signals use NTSC bars with PLUGE signal to all. For RGB and digital video signals use a colorimeter and test color signal software to confirm consistent images.
30. For RGB sources, demonstrate 700 mV +/- 10% (or 1 dB) from each source to each destination. (If requested only) record results using a flat-field pattern signal at the highest resolution specified, or at least 1024 by 768 resolution (VESA 8). For RGB sources measure and record peak-to-peak voltage for peak white signal, and record "peak" and "Level" control settings on any interface at the positions whereby the 700 mV voltages were attained.
31. Displays are focused, centered, and evenly illuminated. If requested, confirm using the calibrated light meter that the brightest measurement locations shall be no more than +10% above average, and the dimmest locations no less than -5% below average measurement. Also if requested, document that geometric distortion is within 2% tolerance. Take actual measurements if necessary (top, bottom, left, right dimensions of white portion of screen) and photograph if necessary.
32. Display stable images, with no scaling-related visual artifacts when switching between, at a minimum, _____(1024 x 768), (1280 x 1024), (1920 x 1080) and (1280 x 720) sources, and/or all those specified in the performance criteria for this system. Record test results.
33. The display is able to switch between different color spaces and resolutions. Show a Blu-ray or TV (YUV) signal, then show a laptop (RGB) signal, and then switch back to the Blu-ray/TV (YUV) signal. The source should always display properly.
34. Automatic CEC controls do not affect the displays. With the displays powered on, power off each source in the system. The displays should remain on (no Power Off command sent from a source).
35. All sources can be routed to all expected destinations. Disregard any routes that are not permitted by design, as described in the narrative, such as HDCP sources routed to a codec.
36. All HDCP sources can be routed to all expected destinations at the same time. There are some devices with a limited capability to display on multiple displays. The system requires that each source can display on the required number of displays in the system.
37. For HDMI signals, test using the entire cabling to be installed in the field, to the extent it is possible. Using an HDMI generator, display pixel on/pixel off, with HDCP enabled, for the following resolutions: 1920x1200@60, 1920x1080@60, 1600x1200@60, 1280x720@60,

1280x768@60, 1280x800@60, 1024x768@60, 800x600@60, 640x480@60 (base default, in case the PC has issues and boots up in default mode). Inspect each, leaving the signal on for several seconds (no "sparklies"). HDMI Generator required

38. Perform all "Source Tests" with HDMI tester on each source, especially Format Analyzer, Video Display, Audio Analyzer, and HDCP Tests immediately before all the sinks (displays) in the system. Test will verify source integrity and EDID information. QD 780 Analyzer required.
39. Perform "Sink Test" with HDMI tester on each display. Test will verify display can handle various resolutions, and spot check EDID to make sure they work with all sources. QD 780 Analyzer required.
40. Using a static video source, perform a pixel by pixel comparison through entire signal chain from each source location. Test will compare ten frames. Set generator to the highest resolution supported by the system, route to each display, and compare frames at each display. Repeat for every source location. QD 780 Analyzer and separate HDMI generator required.
41. If the switcher makes available a system status report with information regarding each source and destination signal integrity, EDID and CEC status information, etc., then obtain a report. If a printed or 'pdf' report is not included, take a screen print showing the status of the system (including source and destination communications with the switcher) and include it in the Report.
42. When testing Blu-ray, confirm that the movie plays. Sometimes HDCP is not enabled during the menus and previews, but only during the movie. Blu-ray disc required.
43. Confirm typical client laptops have been successfully used with the system, inclusive of default resolution (works with switcher EDID), any adapters, etc. Client laptop required.
44. For laptops with digital outputs: if the audio is not embedded in an HDMI connection, or if the user connects to his audio out, is the analog audio satisfactorily distributed? Client laptop required.
45. The Control System performs all the functions as indicated on the function list ("control system specification") provided, with stability, and in sync with the equipment being controlled without the need to reset any item of equipment.
46. When system is powered down, system "up" sequence presents the system in a desirable state with no objectionable anomalies.
47. Be serviceable. This includes accessibility to equipment to be easily pulled for repair by one person, neatly dressed cables, bundled in forms (refer to Giddings, Davis and Davis), having no excessive pressure on cables at termination points and connectors, utilize service loops, and have each cable number in agreement with the as-built drawings. This includes the equipment rack itself. All switches and receptacles shall be logically and permanently labeled.
48. Image size relative to furthest viewer ratio:____(1:6) Record each, compare to recommended ratio. (The Owner has in some cases has requested displays with image sizes that do not comply with industry best practices).
49. Confirm all nomenclature for consistency: drawings, touch screen, wall plates, floor boxes, patch panels, equipment, etc.
50. Patch cables have cable numbers.
51. Inspect camera image quality.
52. Camera presets are programmed as specified by the user.
53. Confirm acceptable TV levels, and any channel presets are accurate.
54. Confirm that all codec options specified by the customer have been installed.

55. IP information provided by client and loaded into system, including IP address, network ID's, subnet masks, default gateway, timeserver, Gatekeeper, alias, hostnames, etc. All network functions specified by the customer are shown to function properly on customer's LAN. These settings are listed in a report that will remain with the system.
56. Any web-based system control or monitoring features, and other IP functionality of system (time servers, system-generated e-mail, etc.) thoroughly tested.
57. Displays have On-Screen Displays/Menus Are Disabled, or as specified by the user.
58. Video projector, if any, must have 'blue screen' or 'no image screen' disabled, or as directed by the user.
59. Log all test conference calls (audio and video). Log should include time, line used, number called, success of connection, who we spoke with, success of full duplex, success of auto disconnect, level in the room, note static or jitter/packet loss, etc. Note if auto disconnect functions as specified.
60. Confirm there are no lost or stuck "on" pixels when Full White Test signal is displayed (follow manufacturer's specification). Note number and location of lost pixels, if any.
61. Check for excessive vibration on VC camera(s) at full telephoto position.
62. Video record non-conformances and anomalies as required, facilitating corrective actions.
63. Sanity check: would the user object to anything about this system? Is everything plumb and square, clean and blemish-free? Are displays and equipment free of fingerprints and dust?
64. Does the system under test satisfy ALL of the system requirements as laid out by the client-approved narrative/signed proposal?
65. Prepare document report, certifying the product, performance, and practices are in compliance, and noting any exceptions. Distribute accordingly.
66. Once successful completion of the On-Site Prototype Checkout has been acknowledged the Installing Contractor can continue the build-out of the other like rooms.

G. Full System Checkout

1. Installing Contractor's Full System Checkout
 - a. Installing Contractor will accomplish a complete system(s) inventory of all equipment, and inspection of all workmanship quality relating to installation details.
 - b. Installing Contractor will complete all testing for system operational compliance, and test to ensure all equipment is working fully to published specifications
 - c. Results will be recorded and submitted to the Owner. Installing Contractor's test submittal will serve to allow 7-days for the Owner to make arrangements to do Final System Checkout.
 - d. A physical inventory will be taken of all equipment on site and will be compared to equipment lists in the contract documents and subsequent Installing Contractor submittals.
 - e. The operation of all system equipment shall be demonstrated by the Installing Contractor.
 - f. Both subjective and objective tests will be required to determine compliance with the specifications.
 - g. The Installing Contractor shall be responsible for providing test equipment for these tests.
 - h. The Installing Contractor shall be responsible for providing qualified personnel to run the tests, make adjustments, and answer system questions for as long as required to accomplish the tests and setup satisfactorily.

- i. The Installing Contractor shall be responsible for providing the personnel that accomplished all programming for the system; this includes the control system and any DSP software. This person will be available to run requested demonstration, make adjustments, and answer system programming questions for as long as required to accomplish the demonstration satisfactorily.
- j. In the event there is required rework, large scale readjustments, or defective equipment that must be repaired or replaced, tests may be suspended or continued at the option of the Owner. Owner will advise if training can commence while any further clean-up is being done before Final System Checkout.

3.03 SYSTEM ACCEPTANCE TESTS

- A. System Acceptance Tests will not be performed until the AV Contractor's System Checkout has been completed and the test results have been reviewed. The System Acceptance Tests will be supervised by the AV Consultant and will consist of the following:
- B. A physical inventory will be taken of all equipment on site and will be compared to equipment lists in the contract documents.
- C. The operation of all system equipment shall be demonstrated by the AV Contractor.
- D. Both subjective and objective tests will be required by the AV Consultant to determine compliance with the specifications. The AV Contractor shall be responsible for providing test equipment for these tests.
- E. All final, "as-built" drawings, run sheets, manuals, and other required documents, as detailed in Part I, shall be on hand. Two complete sets of these documents shall be delivered to the Owner and the AV Consultant at this time. (One complete set shall have been delivered to the AV Consultant prior to the scheduling of Acceptance Tests).
- F. In the event further adjustment is required, or defective equipment must be repaired or replaced, tests may be suspended or continued at the option of the AV Consultant.
- G. Any charge for additional time incurred by the AV Consultant required to oversee the system tests, due to improper system installation or previous failed systems, shall be the responsibility of, and charged directly to the AV Contractor.

3.04 TRAINING

- A. The Installing Contractor shall provide on-the-job training by a qualified instructor, to personnel designated by the Owner, to instruct them in the operation and routine maintenance of the systems.
 - 1. All training shall take place after the systems are operational, but before the acceptance tests.
 - 2. Operational Training:
 - a. There shall be a minimum of eight (8) hours of end-user training included in this specification for this activity.
 - b. In the event the Installing Contractor does not have qualified instructors on staff for certain sophisticated equipment, the Installing Contractor, at no additional cost to Owner, will provide a manufacturer's representative for such instruction to the Owner.
 - c. Training Materials Supplied:
 - 1) System operational manual (not equipment operation manuals) that explains how to fully operate the system; from start-up to shut-down, and all operational steps in-between, in a step by step description, with pictures and other visuals to help convey information.

- 2) The Installing Contractor shall video record training session(s) for Owners reference (to help limit minor follow up phone calls in the future).
3. Maintenance Training:
 - a. A session with Owner's designated technical personnel for routine and preventive maintenance will be given.
 - 1) This training is for scheduled preventative maintenance for such items as filter and lens cleaning, minor equipment checks and "user" adjustments.
 - a) This training is not meant to teach Owner's representatives how to use commercial test equipment and/or do sophisticated equipment/system alignment.
 - b. There shall be a minimum of four (4) hours of end-user training included in this specification for this activity.
 - c. Training Materials Supplied:
 - 1) Utilizing the equipment manuals and flow diagrams of the required in contract closeout submittals supply a listing with suggested preventative maintenance schedule of the system equipment.
 - d. Follow-up training within sixty (60) days shall also be provided.
 - 1) There shall be a minimum of eight (8) hours of end-user training included in this specification for this activity.

3.05 RECOGNITION

- A. Configuration:
 1. Engraved Rack Panel
 2. All installations shall bear the following identification rack panel, supplied by this contractor, mounted on the front of the main rack at the top:

SYSTEMS DESIGNED BY:
SHEN MILSOM & WILKE, LLC
2 N. Riverside Plaza, Suite 1460,
Chicago, IL 60606
Tel: 312-559-4585

SYSTEMS FABRICATED & INSTALLED BY:
(AV Contractor name address and contact information)

3.06 APPENDIX A – EQUIPMENT LISTS

- A. Refer to Appendix A for the equipment lists for the audiovisual systems. These lists are provided for reference only. Bidder/AVC to include all equipment necessary to provide a complete and operational system.

END OF SECTION

Appendix A						
Chef's Table & Private Dining 1001,1002,1004						
Item #	Product	Manuf.	Model #	Unit	Qty	Ext.
CONTROL						
1	iOS Tablet Device	Apple	Air II		1	
2	Docking Station for Apple Air II with through desk mount and quick release	Monitors in Motion	Tablet Docking Station		1	
	Other control systems components through custom quotation process	Extron	Custom Quote #6663147	[Refer to Custom Quotation Page #9, Appendix A]		
DISPLAY AND VIDEO						
3	24" Class Flat Panel Display	Samsung	UN24H4500AFXZA		2	
4	55" Flat Panel Display	Sharp	PN-Y555		3	
5	Desktop Mount for 24" Display w/through desk mount and VESA adaptor plate	Monitors in Motion	BOA		2	
6	Wall Mount for 55" Flat Panel Display	Premier	CTM-MS2		2	
7	Wall Mount for Recessed 55" Flat Panel Display	Chief	MWR1W		1	
8	In-Wall Accessory Kit	Chief	PAC525FCW		1	
9	HD PTZ Video Camera	Vaddio	RoboShot 30 HDMI		2	
	Other video transport & switching systems components through custom quotation process	Extron	Custom Quote #6663147	[Refer to Custom Quotation Page #9, Appendix A]		
AUDIO						
10	Wireless Microphone System	Shure	QLXD14/93		1	
11	Podium Miniature Gooseneck Microphone with momentary switch	Shure	MX418		1	
12	Pendant Ceiling 70V Loudspeaker	JBL	Control 64 PT		4	
13	Ceiling Loudspeaker 70V	JBL	Control 26DT		9	
14	Ceiling Loudspeaker Back Can	Atlas	BMT95-8-7		9	
15	Wall Mount Columnar Loudspeaker (each)	Innovox	SL-2.1US		2	
MISCELLANEOUS HARDWARE						
16	8 Gang Floor Box	Wiremold Legrand	EFB8S-OG		1	
17	Custom I/O panels				LOT	
18	Miscellaneous hardware, switches, relays panels, connectors, cabling, lamps, terminal blocks, etc., necessary to insure a complete and operating system.				LOT	
19	Set audiovisual systems functional drawings, shall be photo-reproduced laminated & stored in pocket, audiovisual equipment racks.				LOT	
NOTE: Floor Box Pre-Purchased as part of the AV budget; back box installed by GC; AV connectivity plates and cover plate installed by AV Contractor						
NOTE: AV Integrator to coordinate with the Architect and Owner exact locations for displays, cameras and touch control panels with desktop or articulating arm mounts						
NOTE: Electric Projection Screen to be provided by the AV Integrator; Screen Casing to be installed by CDB General Contractor; screen roller to be installed by AV Integrator						

Appendix A						
Demonstration Lab & Control Room 2003,2003A						
Item #	Product	Manuf.	Model #	Unit	Qty	Ext.
CONTROL (see Display & Video)						
1	Tablet Control App/License for tablet users	Extron	LinkLicense		1	
2	iOS Tablet Device	Apple	Air II		2	
3	Docking Station for Apple Air II with through desk mount and quick release	Monitors in Motion	Tablet Docking Station		2	
	Other control systems components through custom quotation process	Extron	Custom Quote #6663147	[Refer to Custom Quotation Page #9, Appendix A]		
DISPLAY & VIDEO						
4	HD PTZ Video Camera	Vaddio	RoboShot 30 HDMI		3	
5	HD Fixed Lens Video Camera w/manual zoom	Vaddio	ZoomShot20 HDMI		1	
6	55" Flat Panel Display	Sharp	PN-Y555		2	
7	Ceiling Mount for 55" Flat Panel Display	Chief	XCM1U		2	
8	Ceiling Mount for PTZ camera	Vaddio			3	
9	Wall mount for PTZ camera	Vaddio			1	
10	24" Flat Panel Display	Sharp	PN-Y325		3	
11	Wall Mount for 24" Flat Panel Display	Premier	DS509		3	
	Other video transport & switching systems components through custom quotation process	Extron	Custom Quote #6663147	[Refer to Custom Quotation Page #9, Appendix A]		
AUDIO						
12	Wireless Microphone System	Shure	QLXD14/93		1	
13	Pendant Ceiling 70V Loudspeaker	JBL	Control 64 PT		4	
14	4 CH Power Amplifier 260W per CH	Crown	CTS4200		1	
15	2CH Power Amplifier 300W per CH	Crown	CTS600		1	
MISCELLANEOUS HARDWARE						
16	Full Height Equipment Rack	Middle Atlantic	WRK-44-32		1	
17	Caster Base for WRK-44-32	Middle Atlantic	CBS-MRK-31		1	
18	Partial Height Equipment Rack	Middle Atlantic	WRK-24-32		1	
19	AV Rack Power Strips with Surge Protection	SurgeX	SX1120-RT		2	
20	Custom I/O panels				LOT	

Appendix A						
Demonstration Lab & Control Room 2003,2003A						
Item #	Product	Manuf.	Model #	Unit	Qty	Ext.
21	Miscellaneous hardware, switches, relays panels, connectors, cabling, lamps, terminal blocks, etc., necessary to insure a complete and operating system.			_____	LOT	_____
22	Set audiovisual systems functional drawings, shall be photo-reproduced laminated & stored in pocket, audiovisual equipment racks.			_____	LOT	_____
NOTE: Floor Box Pre-Purchased as part of the AV budget; back box installed by GC; AV connectivity plates and cover plate installed by AV Contractor						
NOTE: AV Integrator to coordinate with the Architect and Owner exact locations for displays, cameras and touch control panels with desktop or articulating arm mounts						

Appendix A						
Competition Lab 2002						
Item #	Product	Manuf.	Model #	Unit	Qty	Ext.
CONTROL (see Display & Video)						
1	iOS Tablet Device	Apple	Air II	_____	1	_____
2	Docking Station for Apple Air II with through desk mount and quick release	Monitors in Motion	Tablet Docking Station	_____	1	_____
3	Foot Switch Controller - For momentary camera switching trigger	Altech	FL1 SU1	_____	1	_____
	Other control systems components through custom quotation process	Extron	Custom Quote #6663147	[Refer to Custom Quotation Page #9, Appendix A]		
DISPLAY & VIDEO						
4	HD PTZ Video Camera	Vaddio	RoboShot 30 HDMI	_____	6	_____
5	Ceiling Mount for PTZ Camera	Vaddio		_____	6	_____
6	47" Flat Panel Display	Sharp	PN-Y475	_____	1	_____
7	32" Flat Panel Display	Sharp	PN-Y325	_____	2	_____
8	Wall Mount for 47" Flat Panel Display	Premier	CTM-MS2	_____	1	_____
9	Ceiling Mount for 32" Flat Panel Display	Chief	LCM Single Display	_____	2	_____
	Other video transport & switching systems components through custom quotation process	Extron	Custom Quote #6663147	[Refer to Custom Quotation Page #9, Appendix A]		
AUDIO						
10	Wireless Microphone System	Shure	QLXD14/93	_____	1	_____
11	Ceiling Loudspeaker 70V	JBL	Control 26CT	_____	15	_____
MISCELLANEOUS HARDWARE						
12	Custom I/O panels			_____	LOT	_____
13	Miscellaneous hardware, switches, relays panels, connectors, cabling, lamps, terminal blocks, etc., necessary to insure a complete and operating system.			_____	LOT	_____
14	Set audiovisual systems functional drawings, shall be photo-reproduced laminated & stored in pocket, audiovisual equipment racks.			_____	LOT	_____
NOTE: Floor Box Pre-Purchased as part of the AV budget; back box installed by GC; AV connectivity plates and cover plate installed by AV Contractor						
NOTE: AV Integrator to coordinate with the Architect and Owner exact locations for displays, cameras and touch control panels with desktop or articulating arm mounts						

Appendix A						
Student Dining & Servery 2000, 2001						
Item #	Product	Manuf.	Model #	Unit	Qty	Ext.
CONTROL (see Display & Video)						
1	AV Control - Handheld remote included with projector	Epson	N/A	_____	1	_____
DISPLAY & VIDEO						
2	70" Flat Panel Display	Sharp	PN-R703	_____	1	_____
3	47" Flat Panel Display	Sharp	PN-Y475	_____	2	_____
4	Video Projector Ceiling Mount Adaptor	BMS	LCD-LOCII	_____	1	_____
5	1.5" Pipe and other required hardware for projector mount to building structure					
6	4000 Lumen Video Projector	Epson	4855WU	_____	1	_____
	Other video transport & switching systems components through custom quotation process	Extron	Custom Quote #6663147	[Refer to Custom Quotation Page #9, Appendix A]		
AUDIO						
7	Ceiling Loudspeaker 70V	JBL	Control 26DT	_____	6	_____
8	Ceiling Loudspeaker Back Can	Atlas	BMT95-8-7	_____	6	_____
MISCELLANEOUS HARDWARE						
9	Electric Ceiling Mount Projection Screen	Da-Lite	#20848LS Tensioned Advantage	_____	1	_____
10	Key Switch for Projection Screen	Da-Lite		_____	1	_____
11	Custom I/O panels			_____	LOT	_____
12	Miscellaneous hardware, switches, relays panels, connectors, cabling, lamps, terminal blocks, etc., necessary to insure a complete and operating system.			_____	LOT	_____
13	Set audiovisual systems functional drawings, shall be photo-reproduced laminated & stored in pocket, audiovisual equipment racks.			_____	LOT	_____
NOTE: Video Projector Purchased by Owner as part of the AV budget; installed by AV contractor						
NOTE: Projection Screens Purchased by Owner as part of the AV budget; installed by AV Contractor						
NOTE: AV Integrator to coordinate with the Architect and Owner exact locations for displays, cameras and touch control panels with desktop or articulating arm mounts						

Appendix A						
Garde Manger 3002 (Culinary Lab)						
Item #	Product	Manuf.	Model #	Unit	Qty	Ext.
CONTROL (see Display & Video)						
1	Tablet Control App/License for tablet users				1	
2	iOS Tablet Device	Apple	Air II		1	
3	Docking Station for Apple Air II with through desk mount and quick release	Monitors in Motion	Tablet Docking Station		1	
4	Foot Switch Controller - For momentary camera switching trigger	Altech	FL1 SU1		1	
	Other control systems components through custom quotation process	Extron	Custom Quote #6663147	[Refer to Custom Quotation Page #9, Appendix A]		
DISPLAY & VIDEO						
5	HD PTZ Video Camera	Vaddio	RoboShot 30 HDMI		1	
6	HD Fixed Video Camera (Future)	Vaddio	ZoomSHOT 20		0	
7	47" Flat Panel Display	Sharp	PN-Y475		2	
8	32" Flat Panel Display	Sharp	PN-Y325		1	
9	Ceiling Pole Mount for 47" FPD				2	
10	Ceiling Pole Mount for 32" FPD					
11	Ceiling Mount for PTZ camera				1	
	Other video transport & switching systems components through custom quotation process	Extron	Custom Quote #6663147	[Refer to Custom Quotation Page #9, Appendix A]		
MISCELLANEOUS HARDWARE						
12	Custom I/O panels				LOT	
13	Miscellaneous hardware, switches, relays panels, connectors, cabling, lamps, terminal blocks, etc., necessary to insure a complete and operating system.				LOT	
14	Set audiovisual systems functional drawings, shall be photo-reproduced laminated & stored in pocket, audiovisual equipment racks.				LOT	
NOTE: Floor Box Pre-Purchased as part of the AV budget; back box installed by GC; AV connectivity plates and cover plate installed by AV Contractor						
NOTE: AV Integrator to coordinate with the Architect and Owner exact locations for displays, cameras and touch control panels with desktop or articulating arm mounts						

Appendix A						
Baking Pastry Labs 4001, 4008, 4009						
Item #	Product	Manuf.	Model #	Unit	Qty	Ext.
CONTROL (see Display & Video)						
1						
2	Tablet Control App/License for tablet users				1	
3	iOS Tablet Device	Apple	Air II		3	
4	Docking Station for Apple Air II with through desk mount and quick release	Monitors in Motion	Tablet Docking Station		1	
5	Foot Switch Controller - For momentary camera switching trigger	Altech	FL1 SU1		1	
	Other control systems components through custom quotation process	Extron	Custom Quote #6663147	[Refer to Custom Quotation Page #9, Appendix A]		
DISPLAY & VIDEO						
6	HD PTZ Video Camera	Vaddio	RoboShot 30 HDMI		1	
7	HD Fixed Video Camera	Vaddio	ZoomSHOT 20		1	
8	55" Flat Panel Display	Sharp	PN-Y555		2	
9	Ceiling Pole Mount for 55" FPD				2	
10	24" Class Flat Panel Display	Samsung	UN24H4500AFXZA		2	
11	Ceiling Pole Dual Mount				2	
	Other video transport & switching systems components through custom quotation process	Extron	Custom Quote #6663147	[Refer to Custom Quotation Page #9, Appendix A]		
MISCELLANEOUS HARDWARE						
12	Custom I/O panels				LOT	
13	Miscellaneous hardware, switches, relays panels, connectors, cabling, lamps, terminal blocks, etc., necessary to insure a complete and operating system.				LOT	
14	Set audiovisual systems functional drawings, shall be photo-reproduced laminated & stored in pocket, audiovisual equipment racks.				LOT	
NOTE: Floor Box Pre-Purchased as part of the AV budget; back box installed by GC; AV connectivity plates and cover plate installed by AV Contractor						
NOTE: AV Integrator to coordinate with the Architect and Owner exact locations for displays, cameras and touch control panels with desktop or articulating arm mounts						

Appendix A						
Production Labs 5001,5008						
Item #	Product	Manuf.	Model #	Unit	Qty	Ext.
CONTROL (see Display & Video)						
1	Tablet Control App/License for tablet users				1	
2	iOS Tablet Device	Apple	Air II		1	
3	Docking Station for Apple Air II with through desk mount and quick release	Monitors in Motion	Tablet Docking Station		1	
4	Foot Switch Controller - For momentary camera switching trigger	Altech	FL1 SU1		1	
	Other control systems components through custom quotation process	Extron	Custom Quote #6663147	[Refer to Custom Quotation Page #9, Appendix A]		
DISPLAY & VIDEO						
5	55" Flat Panel Display	Sharp	PN-Y555		2	
6	32" Flat Panel Display	Sharp	PN-Y325		2	
7	Ceiling Mount for 55" Flat Panel Display	Chief	XCM1U		2	
8	Ceiling Mount for 32" Flat Panel Display	Chief	LCM Single Display		2	
9	HD PTZ Video Camera	Vaddio	RoboShot 30 HDMI		1	
10	HD Fixed Lens Video Camera	Vaddio	ZoomSHOT 20		1	
11	Ceiling Mount for PTZ camera	Vaddio			1	
12	Wall Mount for Fixed Lens Camera	Vaddio			1	
	Other video transport & switching systems components through custom quotation process	Extron	Custom Quote #6663147	[Refer to Custom Quotation Page #9, Appendix A]		
MISCELLANEOUS HARDWARE						
13	Custom I/O panels				LOT	
14	Miscellaneous hardware, switches, relays panels, connectors, cabling, lamps, terminal blocks, etc., necessary to insure a complete and operating system.				LOT	
15	Set audiovisual systems functional drawings, shall be photo-reproduced laminated & stored in pocket, audiovisual equipment racks.				LOT	
NOTE: Floor Box Pre-Purchased as part of the AV budget; back box installed by GC; AV connectivity plates and cover plate installed by AV Contractor						
NOTE: AV Integrator to coordinate with the Architect and Owner exact locations for displays, cameras and touch control panels with desktop or articulating arm mounts						

Appendix A						
Meat Lab						
Item #	Product	Manuf.	Model #	Unit	Qty	Ext.
CONTROL (see Display & Video)						
1	AV Control - Handheld remote included with flat panel display	Sharp	N/A	_____	1	_____
DISPLAY & VIDEO						
2	HD Fixed Lens Video Camera w/manual	Vaddio	ZoomShot20 HDMI	_____	1	_____
3	47" Flat Panel Display	Sharp	PN-Y475	_____	1	_____
4	Wall mount for 47" Flat Panel Display	Premier	P2642F	_____	1	_____
5	Articulating arm with through desk mount for Fixed Lens Camera	Cuzzi	DW630W	_____	1	_____
	Other video transport & switching systems components through custom quotation process	Extron	Custom Quote #6663147	[Refer to Custom Quotation Page #9, Appendix A]		
MISCELLANEOUS HARDWARE						
6	Custom I/O panels			_____	LOT	_____
7	Miscellaneous hardware, switches, relays panels, connectors, cabling, lamps, terminal blocks, etc., necessary to insure a complete and operating system.			_____	LOT	_____
8	Set audiovisual systems functional drawings, shall be photo-reproduced laminated & stored in pocket, audiovisual equipment racks.			_____	LOT	_____
NOTE: AV Integrator to coordinate with the Architect and Owner exact locations for displays, cameras and touch control panels with desktop or articulating arm mounts						

Appendix A						
Custom Quotes						
Item #	Product	Manuf.	Model #	Unit	Qty	Ext.
1	Control Systems Package	Extron	Custom Quote #6663147	_____	1	_____
2	Add Alternate: Design Build Quote for IPTV System	AV Bidding Contractors		_____	LOT	_____

Appendix A						
Classrooms, Typical						
Item #	Product	Manuf.	Model #	Unit	Qty	Ext.
CONTROL (see Display & Video)						
1	AV Control - Handheld remote included with projector	Epson	N/A	_____	1	_____
DISPLAY & VIDEO						
2	3400 Lumen Short Throw Video Projector including Arm Projector Mount and other required hardware	Epson	PL535W	_____	1	_____
AUDIO						
3	Small Format Power Amplifier 40W/70V	Extron	MPA401	_____	1	_____
4	Ceiling Loudspeaker 70V	JBL	Control 26CT	_____	4	_____
MISCELLANEOUS HARDWARE						
5	Poke Through Box	Wiremold Legrand	8STC	_____	1	_____
6	Manual Wall Mount Projection Screen	Da-Lite	#36441 Advantage Manual	_____	1	_____
7	Custom I/O panels			_____	LOT	_____
8	Miscellaneous hardware, switches, relays panels, connectors, cabling, lamps, terminal blocks, etc., necessary to insure a complete and operating system.			_____	LOT	_____
9	Set audiovisual systems functional drawings, shall be photo-reproduced laminated & stored in pocket, audiovisual equipment racks.			_____	LOT	_____
NOTE: Floor Boxes Pre-Purchased as part of the AV budget; back box installed by GC; AV connectivity plates and cover plate installed by AV Contractor						
NOTE: Video Projectors Purchased by Owner as part of the AV budget; installed by AV Contractor						
NOTE: Projection Screens Purchased by Owner as part of the AV budget; installed by AV Contractor						

Appendix A						
Classroom, Standard Projection 5004						
Item #	Product	Manuf.	Model #	Unit	Qty	Ext.
CONTROL (see Display & Video)						
1	AV Control - Handheld remote included with projector	Epson	N/A	_____	1	_____
DISPLAY & VIDEO						
2	4000 Lumen Video Projector - Ceiling Mount	Epson	4855WU	_____	1	_____
3	Video Projector Ceiling Mount Adaptor	BMS	LCD-LOCII	_____	1	_____
4	1.5" Pipe and other required hardware for projector mount to building structure	N/A	N/A	_____		_____
AUDIO						
5	Small Format Power Amplifier 40W/70V	Extron	MPA401	_____	1	_____
6	Ceiling Loudspeaker 70V	JBL	Control 26CT	_____	4	_____
MISCELLANEOUS HARDWARE						
7	Manual Wall Mount Projection Screen	Da-Lite	#20902 Advantage Manual	_____	1	_____
8	Custom I/O panels				LOT	_____
9	Miscellaneous hardware, switches, relays panels, connectors, cabling, lamps, terminal blocks, etc., necessary to insure a complete and operating system.			_____	LOT	_____
10	Set audiovisual systems functional drawings, shall be photo-reproduced laminated & stored in pocket, audiovisual equipment racks.			_____	LOT	_____
NOTE: Video Projectors Purchased by Owner as part of the AV budget; installed by AV Contractor						
NOTE: Projection Screens Purchased by Owner as part of the AV budget; installed by AV Contractor						

Appendix A							
General Student Spaces 1000, 1102, 6004, 6005D, 6005E (Lobby, Elevators, Lounges, Group Study, Tutoring)							
Item #	Product	Manuf.	Model #	Unit	Qty	Ext.	
CONTROL (see Display & Video)							
1	AV Control - Handheld remote included with projector	Epson	N/A	_____	1	_____	
2	AV Control - Handheld remote included with flat panel display	Sharp	N/A	_____	1	_____	
DISPLAY & VIDEO							
3	80" Flat Panel Display	Sharp	PN-E803	_____	1	_____	
4	32" Flat Panel Display	Sharp	PN-Y325	_____	1	_____	
5	55" Flat Panel Display	Sharp	PN-555	_____	2	_____	
6	Wall mount for recessed 80" FPD	Chief	PWR1W	_____	1	_____	
7	Wall mount for recessed 32" FPD	Chief	MWR1W	_____	1	_____	
8	Wall mount for 55" FPD	Premier	CTM-MS2	_____	2	_____	
9	3400 Lumen Short Throw Video Projector	Epson	PL535W	_____	1	_____	
	Other video transport & switching systems components through custom quotation process	Extron	Custom Quote #6663147	[Refer to Custom Quotation Page #9, Appendix A]			
MISCELLANEOUS HARDWARE							
10	Poke Through Box	Wiremold Legrand	8STC	_____	1	_____	
11	Manual Wall Mount Projection Screen	Da-Lite	#36441 Advantage Manual	_____	1	_____	
12	Custom I/O panels			_____	LOT	_____	
13	Miscellaneous hardware, switches, relays panels, connectors, cabling, lamps, terminal blocks, etc., necessary to insure a complete and operating system.			_____	LOT	_____	
14	Set audiovisual systems functional drawings, shall be photo-reproduced laminated & stored in pocket, audiovisual equipment racks.			_____	LOT	_____	
NOTE: Floor Boxes Pre-Purchased as part of the AV budget; back box installed by GC; AV connectivity plates and cover plate installed by AV Contractor							
NOTE: Video Projectors Purchased by Owner as part of the AV budget; installed by AV Contractor							
NOTE: Projection Screens Purchased by Owner as part of the AV budget; installed by AV Contractor							
NOTE: AV Integrator to coordinate with the Architect and Owner exact locations for displays, cameras and touch control panels with desktop or articulating arm mounts							

Appendix A						
Administration Spaces 1008, 1009,3018,6002						(Reception, Front
Desk, Conference Room, Student Support Offices (corridor 3017), Testing Center)						
Item #	Product	Manuf.	Model #	Unit	Qty	Ext.
CONTROL (see Display & Video)						
1	AV Control - Handheld remote included with projector	Epson	N/A		0	
DISPLAY & VIDEO						
2	60" Flat Panel Display	Sharp	PN-R603		1	
3	47" Flat Panel Display	Sharp	PN-Y475		1	
4	32" Flat Panel Display	Sharp	PN-Y325		2	
5	24" Flat Panel Display	Samsung	UN24H4500AFXZA		2	
6	Wall mount for 70" FPD	Chief	LSM1U		1	
7	Wall mount for recessed 47" FPD	Chief	MWR1W		1	
8	Wall mount for 24" Flat Panel Display	Premier	DS509		2	
9	Ceiling Mount for Flat Panel Display	Chief	XCM1U		2	
AUDIO						
10	1CH Audio Power Amplifier 70V	Extron	MPA-401		1	
11	Ceiling Loudspeaker 70V including appropriate back box for Gypsum ceiling	JBL	Control 26DT		4	
MISCELLANEOUS HARDWARE						
12	Poke Through Box	Wiremold Legrand	8STC		1	
13	Custom I/O panels				LOT	
14	Miscellaneous hardware, switches, relays panels, connectors, cabling, lamps, terminal blocks, etc., necessary to insure a complete and operating system.				LOT	
15	Set audiovisual systems functional drawings, shall be photo-reproduced laminated & stored in pocket, audiovisual equipment racks.				LOT	
NOTE: Floor Box Pre-Purchased as part of the AV budget; back box installed by GC; AV connectivity plates and cover plate installed by AV Contractor						
NOTE: AV Integrator to coordinate with the Architect and Owner exact locations for displays, cameras and touch control panels with desktop or articulating arm mounts						

Appendix A						
AV Rack Rooms 5107						
Item #	Product	Manuf.	Model #	Unit	Qty	Ext.
MISCELLANEOUS HARDWARE						
1	44 RU Equipment Rack	Middle Atlantic	MRK4431		1	
2	AV Rack Power Strips with Surge Protection	SurgeX	SX1120-RT		1	
3	Custom I/O panels				LOT	
4	Miscellaneous hardware, switches, relays panels, connectors, cabling, lamps, terminal				LOT	
5	Set audiovisual systems functional drawings, shall be photo-reproduced laminated & stored				LOT	
NOTE: Power and Conduit to be installed and terminated at AV equipment rack						

Appendix A						
Portable Equipment						
Item #	Product	Manuf.	Model #	Unit	Qty	Ext.
1	Assisted Listening System w/ antennae and 4 Receivers, accessories, etc.	Listen Technologies	LS88	_____	1	_____
2	Additional Receivers	Listen Technologies	LR4200-IR	_____	8	_____
3	Charging/Storage Case	Listen Technologies	LA-380	_____	1	_____
4	Wireless Microphone System	Shure	QLXD14/93	_____	2	_____
				_____		_____

Appendix A - Joliet Junior College							
MASTER RECAP - BASE BID SYSTEMS							
AREA	QUANTITY of SPACES	EQUIPMENT	ENGINEERING	PRE-INSTALL	INSTALL	G&A	AREA TOTAL
Chef's Table & Private Dining 1001,1002,1004	1						
Demonstration Lab & Control Room 2003,2003A	1						
Competition Lab 2002	1						
Student Dining & Servery 2000, 2001	1						
Garde Manger 3002 (Culinary Lab)	1						
Baking Pastry Labs 4001, 4008, 4009	3						
Production Labs 5001,5008	2						
Meat Lab	1						
Custom Quotes	1						
Classrooms, Typical	21						
Classroom, Standard Projection 5004	1						
General Student Spaces 1000, 1102, 6004, 6005D, 6005E (Lobby, Elevators, Lounges, Group Study, Test Rooms)	1						
Administration Spaces 1008, 1009,3018,6002 (Reception, Front Desk, Conference Room, Student Support Offices, (see also 2017), Testing)	1						
AV Rack Rooms 5107	1						
Portable Equipment	1						
TOTALS							

JJC CITY CENTER

AUDIO VISUAL DRAWINGS

DRAWING LIST

TA000	DRAWING LIST, NOTES AND SYMBOL LIST
TA101	AUDIOVISUAL LEVEL 01
TA102	AUDIOVISUAL LEVEL 02
TA103	AUDIOVISUAL LEVEL 03
TA104	AUDIOVISUAL LEVEL 04
TA105	AUDIOVISUAL LEVEL 05
TA106	AUDIOVISUAL LEVEL 06
TA201	AUDIOVISUAL RCP LEVEL 01
TA202	AUDIOVISUAL RCP LEVEL 02
TA203	AUDIOVISUAL RCP LEVEL 03
TA204	AUDIOVISUAL RCP LEVEL 04
TA205	AUDIOVISUAL RCP LEVEL 05
TA206	AUDIOVISUAL RCP LEVEL 06
TA301	AUDIOVISUAL LEVEL 01 - INFRASTRUCTURE
TA302	AUDIOVISUAL LEVEL 02 - INFRASTRUCTURE
TA303	AUDIOVISUAL LEVEL 03 - INFRASTRUCTURE
TA304	AUDIOVISUAL LEVEL 04 - INFRASTRUCTURE
TA305	AUDIOVISUAL LEVEL 05 - INFRASTRUCTURE
TA306	AUDIOVISUAL LEVEL 06 - INFRASTRUCTURE
TA401	AUDIOVISUAL RCP LEVEL 01 - INFRASTRUCTURE
TA402	AUDIOVISUAL RCP LEVEL 02 - INFRASTRUCTURE
TA403	AUDIOVISUAL RCP LEVEL 03 - INFRASTRUCTURE
TA404	AUDIOVISUAL RCP LEVEL 04 - INFRASTRUCTURE
TA405	AUDIOVISUAL RCP LEVEL 05 - INFRASTRUCTURE
TA406	AUDIOVISUAL RCP LEVEL 06 - INFRASTRUCTURE
TA500	AUDIOVISUAL RISER DIAGRAMS
TA600	AUDIOVISUAL SCHEDULES
TA701	AUDIOVISUAL SIGNAL FLOW DIAGRAMS
TA702	AUDIOVISUAL SIGNAL FLOW DIAGRAMS
TA703	AUDIOVISUAL SIGNAL FLOW DIAGRAMS
TA704	AUDIOVISUAL SIGNAL FLOW DIAGRAMS
TA704A	AUDIOVISUAL SIGNAL FLOW DIAGRAMS
TA705	AUDIOVISUAL SIGNAL FLOW DIAGRAMS
TA705A	AUDIOVISUAL SIGNAL FLOW DIAGRAMS
TA706	AUDIOVISUAL SIGNAL FLOW DIAGRAMS
TA707	AUDIOVISUAL SIGNAL FLOW DIAGRAMS
TA800	AUDIOVISUAL DETAILS
TA801	AUDIOVISUAL DETAILS
TA802	AUDIOVISUAL DETAILS
TA803	AUDIOVISUAL DETAILS
TA804	AUDIOVISUAL DETAILS
TA805	AUDIOVISUAL DETAILS

ABBREVIATIONS

AFC	- ABOVE FINISHED CEILING	NIC	- NOT IN CONTRACT
AFF	- ABOVE FINISHED FLOOR	OC	- ON CENTER
APP	- ABOVE FINISHED PLATFORM	OD	- OUTSIDE DIAMETER
AS	- ABOVE SLAB	OFE	- OWNER FURNISHED EQUIPMENT
A/V	- AUDIOVISUAL	OSP	- OUTSIDE PLANT CABLE
BFC	- BELOW FINISHED CEILING	PB	- PULLBOX
BSSH	- BUILDING STANDARD SWITCH HEIGHT	PBX	- PRIVATE BRANCH EXCHANGE
BSRH	- BUILDING STANDARD RECEPTACLE HEIGHT	PR	- PAIR
CLG	- CEILING	R/W	- RACEWAY
EC	- EMPTY CONDUIT	SMOF	- SINGLE-MODE OPTICAL FIBER
GND	- GROUND	TEMP	- TEMPORARY
IDF	- INTERMEDIATE DISTRIBUTION FRAME	TGB	- AUDIO/VIDEO GROUNDING BUSBAR
MC	- MAIN CROSS-CONNECT	TGER	- AUDIO/VIDEO SERVICE ENTRANCE ROOM
MCS	- MULTIMEDIA COMMUNICATION SYSTEM	TYP	- TYPICAL
MDF	- MAIN DISTRIBUTION FRAME	UNO	- UNLESS OTHERWISE NOTED
MH	- MAINTENANCE HOLE	UPS	- UNINTERRUPTED POWER SUPPLY
MMOF	- MULTI-MODE OPTICAL FIBER	UTP	- UNSHIELDED TWISTED PAIR
		WP	- WATERPROOF CLOSET
		WS	- WORK STATION
		WW	- WIREWAY

CABLING NOTES

- WIRE AND CABLE SHEATH SHALL BE MAINTAINED TO FINAL DESTINATION. ALL UTP CABLE TERMINATIONS TO MAINTAIN TWIST OF INDIVIDUAL PAIRS TO WITHIN 1/2" OR LESS OF FINAL TERMINATION.
- CABLES RUNNING IN PLENUM AREAS WITHOUT CONDUIT SHALL BE PLENUM RATED CABLE, AND MATCH THE SPECIFIED CABLE ABOVE. IT IS THE RESPONSIBILITY OF THE TECHNOLOGY CONTRACTOR TO INSPECT THE ELECTRICAL DRAWINGS, AND VERIFY IN WHAT SPACES PLENUM CABLE SHALL BE USED.
- PROVIDE DESIGNATION LABELS FOR ALL TERMINATION BLOCKS, PATCH PANELS AND ALL TECHNOLOGY CABLES AT BOTH ENDS. ALL WIRES AND CABLES SHALL BE LABELED WITHIN 6" OF FINAL TERMINATION. ALL LABELS SHALL BE MACHINE PRINTED OR STENCILED.
- INSTALL EACH CABLE SET INDICATED BY THE SYMBOLS LIST FROM THE OUTLET LOCATION BACK TO THE RESPECTIVE SERVING TELECOM CLOSET (UON)
- ALL WIRING, CABLING, SYSTEM DEVICES AND SYSTEM CONTROLS SHALL BE INSTALLED IN COMPLIANCE WITH ALL CODE REQUIREMENTS AND MANUFACTURER'S INSTRUCTIONS AND PRACTICES UNLESS WRITTEN DIRECTION TO THE CONTRARY IS PROVIDED.
- ALL WIRING AND CABLE RUNS IN CEILING AREAS WHERE CABLE TRAYS OR OTHER SIMILAR SUPPORT IS NOT SPECIFIED SHALL BE PROPERLY SUPPORTED BY J-HOOKS AT MAXIMUM OF 5'-0" INTERVALS. CABLES SHALL BE FULLY SUPPORTED USING ONLY CABLE TRAYS, CONDUITS, J-HOOKS AND/OR OTHER SPECIFIED SUPPORT HARDWARE. QUANTITY OF CABLES AND MOUNTING OF HARDWARE SHALL BE IN COMPLIANCE WITH MANUFACTURER INSTRUCTIONS AND SPECIFIED MAXIMUM FILL RATIOS.

GENERAL NOTES

- WHERE EXACT DIMENSIONS ARE NOT INDICATED, THE SCALE OF THIS DRAWING IS SUFFICIENTLY ACCURATE FOR DETERMINING THE LOCATION OF EQUIPMENT, JUNCTION BOXES, OUTLET BOXES, WIREWAYS, PANELS, ETC. WHERE EXACT DIMENSIONS ARE INDICATED, THE REFERENCE SURFACE SHALL BE THE FINAL FINISHED SURFACE INCLUDING ANY ACOUSTICAL TREATMENT. ROOM DIMENSIONS ON THE DRAWINGS HAVE BEEN TAKEN FROM PRELIMINARY ARCHITECTURAL DRAWINGS. ALL DIMENSIONS MUST BE VERIFIED AND ANY DEVIATIONS CAUSING CHANGES EXCEEDING 3 INCHES MUST BE COORDINATED WITH THE ARCHITECT AND SHEN MILSOM & WILKE, INC.
- DIMENSIONS SHOWN ARE SUGGESTED PLACEMENTS AND ARE PROVIDED FOR INFORMATION ONLY. COORDINATE ALL ELECTRICAL DEVICES AND DIMENSIONED LOCATIONS WITH ARCHITECTURAL AND ENGINEERING DRAWINGS. FOR TECHNOLOGY DEVICES, LIGHTING AND SWITCH LOCATIONS REFER TO THE ARCHITECTURAL DRAWINGS.
- DRAWINGS ARE NOT TO BE USED FOR ARCHITECTURAL OR ENGINEERING PURPOSES. DRAWINGS SHOULD ONLY BE USED FOR TECHNOLOGY SYSTEM INSTALLATION & COORDINATION WITH OTHER CONTRACTORS AND SYSTEMS. COORDINATE PATHWAYS FOR ALL TECHNOLOGY RELATED DEVICES WITH ARCHITECTURAL AND ELECTRICAL PLANS.
- ALL TECHNOLOGY DEVICES SHALL BE SECURELY MOUNTED PLUMB AND STRAIGHT TO WALLS, FLOORS, OR RACKS, PER THE MANUFACTURER'S RECOMMENDED MOUNTING PRACTICE.
- ALL EQUIPMENT SHOWN IN PHANTOM IS FOR REFERENCE ONLY. SUCH EQUIPMENT WILL BE PROVIDED AND INSTALLED BY THE TECHNOLOGY TRADE CONTRACTOR.
- INSTALL FIRESTOP TO ALL SLAB AND WALL PENETRATIONS PROVIDED FOR THE INSTALLATION OF CABLE AS REQUIRED TO MAINTAIN FIRE RATING OF SLAB OR WALL. REVIEW ARCHITECT'S PLAN FOR PARTITION TYPES.
- THE METHOD OF INSTALLATION OF BOXES IN WALLS, AND THE METHOD OF PASSAGE OF CONDUIT AND WIREWAYS THROUGH ACOUSTICALLY SENSITIVE WALLS, SHALL BE COORDINATED WITH THE ACOUSTICAL CONSULTANT OR ARCHITECT.
- ALL ELECTRICAL FOR TECHNOLOGY SHALL BE INSTALLED IN ACCORDANCE WITH LOCAL ELECTRICAL CODE AND SEISMIC REQUIREMENTS.
- REFER TO ELECTRICAL SPECIFICATION FOR INSTALLATION INSTRUCTIONS FOR FLOORBOXES, JUNCTION BOXES, PLYWOOD PANELS, GROUNDING CONDUCTORS, BUSBARS, CONDUITS, CABLE TRAYS IN CORRIDORS, METALLIC ENCLOSURES, ELECTRICAL PANELBOARDS AND CIRCUITING. FIRE PROOFING SYSTEMS USED FOR ALL PENETRATIONS MUST BE APPROVED BY APPLICABLE AUTHORITIES PRIOR TO INSTALLATION.
- ELECTRICAL FEEDS ARE NOT TO BE RUN PARALLEL WITH VIDEO AND/OR AUDIO LINES OR RACEWAYS. IF ELECTRICAL FEEDS MUST BE RUN PARALLEL TO AUDIO/VIDEO LINES, A MINIMUM OF 4'-0" OF SEPARATION MUST BE MAINTAINED.
- POWER BREAKER PANELS ARE SIZED AND SPECIFIED BY THE ELECTRICAL ENGINEER; REFER TO ELECTRICAL DRAWINGS. ALL CIRCUITS SHALL BE PROTECTED BY 120VAC, 20 AMP BREAKERS UNLESS OTHERWISE NOTED.
- POWER RECEPTACLES SHOWN ON TECHNOLOGY DRAWINGS ARE DEDICATED TO SPECIFIC TECHNOLOGY EQUIPMENT AND ARE SHOWN FOR REFERENCE ONLY. THESE RECEPTACLES SHOULD BE ISOLATED GROUND/Common PHASE. REFER TO ELECTRICAL DRAWINGS FOR ADDITIONAL UTILITY POWER RECEPTACLES.
- WHERE POWER CIRCUITS ARE SHOWN TERMINATING INTO JUNCTION BOXES WITHOUT RECEPTACLES, THE WIRES SHALL BE TAPED AND THE BOXES COVERED. THESE CIRCUITS WILL BE CONNECTED BY OTHERS DURING INSTALLATION OF THE TECHNOLOGY SYSTEM EQUIPMENT.
- GROUND ALL CONDUITS, CABLE TRAYS AND JUNCTION BOXES PER THE MANUFACTURER'S RECOMMENDATIONS AND PER ALL APPLICABLE CODES.
- ALL EMPTY CONDUIT SHALL BE REAMED, CLEANED, CAPPED (WHERE APPROPRIATE), TAGGED, AND FURNISHED WITH PULL WIRES.
- INSTALL CABLE TRAY FOR TELECOMMUNICATION WIRING TO MAINTAIN A MINIMUM OF 5" SEPARATION FROM FLUORESCENT LIGHTING.
- THERE SHALL BE A MINIMUM OF ONE PULL BOX FOR EVERY 100' OF STRAIGHT EMPTY CONDUIT AND/OR ONE PULL BOX FOR MORE THAN 90° BENDS OR LESSER BENDS TOTALING 180° IN A CONDUIT RUN.
- MAINTAIN MINIMUM BEND RADIUS OF 10X OD FOR ALL CONDUITS.
- STUB UP CONDUIT SLEEVES THROUGH SLABS 3" ABOVE FINISHED FLOORS, EXCEPT IN THE CASE OF ACCESS FLOORS, IN WHICH CASE STUB UPS SHALL TERMINATE UNDER THE ACCESS FLOOR.
- ALL CABLE TRAY THAT IS SURFACE MOUNTED ON SLAB BELOW RAISED FLOOR SHALL BE SECURELY FASTENED TO SLAB. THESE TRAYS SHALL BE LEFT OPEN AND NOT PROVIDED WITH COVERS.
- PROVIDE CONNECTION HARDWARE, GROUNDING LUGS AND STRAPS, THERMAL EXPANSION PLATES, SUPPORT BRACKETS, SPLICE HARDWARE, TERMINATION KITS, END SUPPORT KITS, CEILING SUPPORT HARDWARE, RUNWAY DROPOFFS AND 7" CABLE RETAINING POSTS FOR ALL CABLE TRAY LOCATIONS PER MANUFACTURER'S RECOMMENDATIONS AND PER APPLICABLE CODES.
- ALL POWER CONDUIT, POWER WIREWAYS, AND POWER JUNCTION BOXES ARE TO BE REVIEWED BY THE ELECTRICAL ENGINEER FOR CODE COMPLIANCE.
- EMPTY CONDUIT RUNS ON THE TECHNOLOGY DRAWINGS SHOW ONLY INTERCONNECTION BETWEEN THE TERMINATION POINTS. THE EXACT PATH OF CONDUIT ARE TO BE DETERMINED BY THE ELECTRICAL ENGINEER AND FIELD CONDITIONS.
- ALL CABLES ARE TO BE IN CONDUIT IN NON-ACCESSIBLE SPACES. THIS INCLUDES BOTH HORIZONTAL AND VERTICAL RUNS. CABLE IN ACCESSIBLE SPACES, HORIZONTAL RUNS ONLY, TO BE PLENUM-RATED CABLE.
- NOTIFY OWNER'S REPRESENTATIVES OF ANY DISCREPANCIES BETWEEN THE EXISTING CONDITIONS AND THE TECHNOLOGY DRAWINGS. OBTAIN CLARIFICATION BEFORE PRECEDING WITH WORK.
- TECHNOLOGY SYSTEMS CONTRACTOR SHALL RESTORE CEILINGS AND WALLS AND ANY OTHER SURFACES AFFECTED BY ITS WORK UPON COMPLETION OF WORK, WITH LIKE MATERIALS TO MATCH EXISTING CONSTRUCTION.
- THE FINISHES FOR ALL JUNCTION BOX FACEPLATES, SPEAKER GRILLES, TABLE BOXES, FLOOR BOXES AND WALL BOXES SHALL BE SUBMITTED TO THE ARCHITECT FOR REVIEW AND APPROVAL PRIOR TO PROCUREMENT. ALL ELECTRICAL BOXES SHALL HAVE THE APPROPRIATE COVERS AND SCREWS INSTALLED BY THE ELECTRICAL CONTRACTOR TO MATCH THE FIT AND FINISH SPECIFIED BY THE ARCHITECT.
- IT SHALL BE THE RESPONSIBILITY OF THE TECHNOLOGY CONTRACTOR TO VERIFY SIGNAL/CONDUIT PATHWAYS WITH THE ELECTRICAL ENGINEERS DRAWINGS.

AUDIO VISUAL SYMBOL LIST

SYMBOL (FLOOR MOUNTED)	DESCRIPTION	NOTES																		
FLOOR BOX	MULTI USE FLOOR BOX.	REFER TO FLOOR BOX SCHEDULE																		
SYMBOL (WALL MOUNTED)	DESCRIPTION	NOTES																		
TECHNOLOGY DEVICE	WALL BOX MOUNTED FLUSH WITH FINISHED SURFACE AT LOCATION SHOWN ON AV DRAWINGS. REFER TO TECHNOLOGY DEVICE BOX LEGEND BELOW FOR BOX TYPE AND SIZE.	-																		
DATA OUTLET	DATA OUTLET REQUIRED FOR AV EQUIPMENT. REFER TO DATA DRAWINGS FOR INFRASTRUCTURE REQUIREMENTS.	SUB-NUMBER "X" INDICATES CABLE DROP QUANTITY																		
DUPLEX RECEPTACLE	ELECTRICAL POWER REQUIRED FOR AV EQUIPMENT MOUNTED AT BUILDING STANDARD OUTLET HEIGHT UNLESS NOTED OTHERWISE	-																		
QUADPLEX RECEPTACLE	ELECTRICAL POWER REQUIRED FOR AV EQUIPMENT MOUNTED AT BUILDING STANDARD OUTLET HEIGHT UNLESS NOTED OTHERWISE	-																		
SINGLE RECEPTACLE WITH SUPPLEMENTAL GROUND	ELECTRICAL POWER REQUIRED FOR AV EQUIPMENT MOUNTED AT BUILDING STANDARD OUTLET HEIGHT UNLESS NOTED OTHERWISE. DEVICE TO UTILIZE SUPPLEMENTAL GROUND	-																		
DUPLEX RECEPTACLE WITH SUPPLEMENTAL GROUND	ELECTRICAL POWER REQUIRED FOR AV EQUIPMENT MOUNTED AT BUILDING STANDARD OUTLET HEIGHT UNLESS NOTED OTHERWISE. DEVICE TO UTILIZE SUPPLEMENTAL GROUND	-																		
QUADPLEX RECEPTACLE WITH SUPPLEMENTAL GROUND	ELECTRICAL POWER REQUIRED FOR AV EQUIPMENT MOUNTED AT BUILDING STANDARD OUTLET HEIGHT UNLESS NOTED OTHERWISE. DEVICE TO UTILIZE SUPPLEMENTAL GROUND	-																		
RAISE/LOWER SWITCH	SINGLE GANG OUTLET MOUNTED AT BUILDING STANDARD SWITCH HEIGHT UNLESS NOTED OTHERWISE	-																		
SYMBOL (CEILING MOUNTED)	DESCRIPTION	NOTES																		
TECHNOLOGY DEVICE	CEILING MOUNTED BOX MOUNTED ABOVE ACCESSIBLE CEILING UNLESS OTHERWISE NOTED. REFER TO TECHNOLOGY DEVICE BOX LEGEND BELOW FOR BOX TYPE AND SIZE.	-																		
DATA BOX	DATA DROP REQUIRED FOR AV EQUIPMENT MOUNTED ABOVE ACCESSIBLE CEILING. REFER TO DATA DRAWINGS FOR INFRASTRUCTURE REQUIREMENTS.	SUB-NUMBER "X" INDICATES CABLE DROP QUANTITY																		
PROJECTION SCREEN MOTOR	MOUNT FLUSH IN FINISHED CEILING (UON), REFER TO DRAWING FOR AUDIOVISUAL CONDUIT SIZE.																			
PROJECTION SCREEN RELAY BOX	MOUNT ON SLAB ABOVE FINISHED CEILING (UON). REFER TO DRAWING FOR AUDIOVISUAL CONDUIT SIZE.	SUPPLY LOW-VOLTAGE INTERFACE WITH SCREEN, BY ELECTRICAL CONTRACTOR. MAINTENANCE ACCESS TO BOX SHALL BE PROVIDED BY ARCHITECT.																		
DUPLEX RECEPTACLE	ELECTRICAL POWER REQUIRED FOR AV EQUIPMENT MOUNTED IN FINISHED CEILING UNLESS NOTED OTHERWISE	-																		
QUADPLEX RECEPTACLE	ELECTRICAL POWER REQUIRED FOR AV EQUIPMENT MOUNTED A IN FINISHED CEILING UNLESS NOTED OTHERWISE	-																		
SINGLE RECEPTACLE WITH SUPPLEMENTAL GROUND	ELECTRICAL POWER REQUIRED FOR AV EQUIPMENT MOUNTED IN FINISHED CEILING UNLESS NOTED OTHERWISE. DEVICE TO UTILIZE SUPPLEMENTAL GROUND	-																		
DUPLEX RECEPTACLE WITH SUPPLEMENTAL GROUND	ELECTRICAL POWER REQUIRED FOR AV EQUIPMENT MOUNTED AT BUILDING STANDARD OUTLET HEIGHT UNLESS NOTED OTHERWISE. DEVICE TO UTILIZE SUPPLEMENTAL GROUND	-																		
SYMBOL (OTHER)	DESCRIPTION	NOTES																		
AV EQUIPMENT	AV EQUIPMENT DESIGNATION, REFER TO EQUIPMENT SCHEDULE FOR INFORMATION	-																		
SHEET NOTE	REFER TO SHEET NOTES	-																		
TECHNOLOGY DEVICE BOX LEGEND																				
BOX DESIGNATION ("XX")	BOX DESIGNATIONS ("XX") FOR THE TECHNOLOGY DEVICE BOXES SHOWN ABOVE ARE DEFINED USING THE FOLLOWING DEFINITIONS: AV - AUDIO VISUAL BACKBOX CAM - CAMERA BACKBOX IR - INFRARED TRANSMITTER BACKBOX S - SPEAKER BACKBOX WB - WALL BOX BACKBOX V - VIDEO BACKBOX																			
BOX TYPE ("YY")	BOX TYPE ("YY") FOR THE DEVICE SYMBOLS SHOWN ABOVE ARE DEFINED USING THE FOLLOWING SUB-NUMBER DESIGNATIONS: <table border="1"> <thead> <tr> <th>GANG BOX DEFINITIONS</th> <th>SCREW COVER BOX DEFINITIONS</th> <th>SPECIALTY BACKBOX DEFINITIONS</th> </tr> </thead> <tbody> <tr> <td>1G - SINGLE GANG 2G - TWO GANG 3G - THREE GANG 4G - FOUR GANG 5G - FIVE GANG 6G - SIX GANG</td> <td>SC8 - 8"Wx8"Hx4"D SC12 - 12"Wx12"Hx4"D SC15 - 15"Wx15"Hx4"D SC18 - 18"Wx18"Hx4"D SC24 - 24"Wx24"Hx4"D</td> <td>SPX* - REFER TO SPECIALTY BACKBOX SCHEDULE FOR INFORMATION *X - DESIGNATES TYPE BOXES TO BE INSTALLED PER MANUFACTURERS INSTRUCTIONS.</td> </tr> <tr> <td>STUD PARTITIONS TO UTILIZE 3-1/2" DEEP BOXES WITH APPROPRIATE EXTENSION RING</td> <td>ADDITIONAL BOX DEFINITIONS CAN BE DEFINED IN THE FOLLOWING CONVENTION SCAXBXC A=WIDTH, B=HEIGHT, C=DEPTH</td> <td></td> </tr> <tr> <td>MASONRY BOXES TO BE 3-1/2" DEEP</td> <td>KNOCK OUT CONFIGURATION TO BE DETERMINED BASED ON FIELD CONDITIONS.</td> <td></td> </tr> <tr> <td>FIELD GANGABLE BOXES ARE NOT APPROVED</td> <td>COVERPLATE SCREWS TO BE MOUNTED TOP AND BOTTOM UNLESS NOTED OTHERWISE</td> <td></td> </tr> <tr> <td>COVER SCREWS MOUNTED TOP AND BOTTOM, UNLESS NOTED OTHERWISE</td> <td></td> <td></td> </tr> </tbody> </table>		GANG BOX DEFINITIONS	SCREW COVER BOX DEFINITIONS	SPECIALTY BACKBOX DEFINITIONS	1G - SINGLE GANG 2G - TWO GANG 3G - THREE GANG 4G - FOUR GANG 5G - FIVE GANG 6G - SIX GANG	SC8 - 8"Wx8"Hx4"D SC12 - 12"Wx12"Hx4"D SC15 - 15"Wx15"Hx4"D SC18 - 18"Wx18"Hx4"D SC24 - 24"Wx24"Hx4"D	SPX* - REFER TO SPECIALTY BACKBOX SCHEDULE FOR INFORMATION *X - DESIGNATES TYPE BOXES TO BE INSTALLED PER MANUFACTURERS INSTRUCTIONS.	STUD PARTITIONS TO UTILIZE 3-1/2" DEEP BOXES WITH APPROPRIATE EXTENSION RING	ADDITIONAL BOX DEFINITIONS CAN BE DEFINED IN THE FOLLOWING CONVENTION SCAXBXC A=WIDTH, B=HEIGHT, C=DEPTH		MASONRY BOXES TO BE 3-1/2" DEEP	KNOCK OUT CONFIGURATION TO BE DETERMINED BASED ON FIELD CONDITIONS.		FIELD GANGABLE BOXES ARE NOT APPROVED	COVERPLATE SCREWS TO BE MOUNTED TOP AND BOTTOM UNLESS NOTED OTHERWISE		COVER SCREWS MOUNTED TOP AND BOTTOM, UNLESS NOTED OTHERWISE		
GANG BOX DEFINITIONS	SCREW COVER BOX DEFINITIONS	SPECIALTY BACKBOX DEFINITIONS																		
1G - SINGLE GANG 2G - TWO GANG 3G - THREE GANG 4G - FOUR GANG 5G - FIVE GANG 6G - SIX GANG	SC8 - 8"Wx8"Hx4"D SC12 - 12"Wx12"Hx4"D SC15 - 15"Wx15"Hx4"D SC18 - 18"Wx18"Hx4"D SC24 - 24"Wx24"Hx4"D	SPX* - REFER TO SPECIALTY BACKBOX SCHEDULE FOR INFORMATION *X - DESIGNATES TYPE BOXES TO BE INSTALLED PER MANUFACTURERS INSTRUCTIONS.																		
STUD PARTITIONS TO UTILIZE 3-1/2" DEEP BOXES WITH APPROPRIATE EXTENSION RING	ADDITIONAL BOX DEFINITIONS CAN BE DEFINED IN THE FOLLOWING CONVENTION SCAXBXC A=WIDTH, B=HEIGHT, C=DEPTH																			
MASONRY BOXES TO BE 3-1/2" DEEP	KNOCK OUT CONFIGURATION TO BE DETERMINED BASED ON FIELD CONDITIONS.																			
FIELD GANGABLE BOXES ARE NOT APPROVED	COVERPLATE SCREWS TO BE MOUNTED TOP AND BOTTOM UNLESS NOTED OTHERWISE																			
COVER SCREWS MOUNTED TOP AND BOTTOM, UNLESS NOTED OTHERWISE																				

NOTE: CONTRACTOR SHALL VERIFY ALL DIMENSIONS AND CONDITIONS AT JOB SITE AND BE FULLY RESPONSIBLE FOR SAME.

REVISIONS <table border="1"> <thead> <tr> <th>NO.</th> <th>DESCRIPTION</th> <th>DATE</th> </tr> </thead> <tbody> <tr> <td>01</td> <td>REVISION A</td> <td>09.16.14</td> </tr> <tr> <td>02</td> <td>REVISION B</td> <td>09.16.14</td> </tr> <tr> <td>03</td> <td>REVISION C</td> <td>10.29.14</td> </tr> <tr> <td>04</td> <td>AV 100% DD FINAL REVISION</td> <td>11.24.15</td> </tr> <tr> <td>05</td> <td>100% CD FOR CONSTRUCTION</td> <td>03.25.16</td> </tr> </tbody> </table>			NO.	DESCRIPTION	DATE	01	REVISION A	09.16.14	02	REVISION B	09.16.14	03	REVISION C	10.29.14	04	AV 100% DD FINAL REVISION	11.24.15	05	100% CD FOR CONSTRUCTION	03.25.16	DRAWN TL PREPARED RST TRACED TL CHECKED TL	APPROVED RST APPROVED RST	 DOMINICK A. DEMONICK 001-014360 SIGNED: _____ EXPIRES: _____	 DEMOMICA KEMPER ARCHITECTS 125 N. HALSTED STREET, SUITE 301 CHICAGO, IL 60661 P: 312.496.0000	 KJWW ENGINEERING 1100 WARRENVILLE ROAD, #400W NAPERVILLE, IL 60563 T: 312.559.4585	 E.F. WHITNEY, INC. 568 ANN STREET BIRMINGHAM, MI 48009 T: 248.644.0990	 SHEN MILSOM WILKE LLC 2 N. RIVERSIDE PLAZA CHICAGO, IL 60606 T: 312.559.4585	100% CD FOR CONSTRUCTION DRAWING LIST, NOTES, AND SYMBOLS LIST CITY CENTER CAMPUS JOLIET JUNIOR COLLEGE	PROJECT NO. DATE APRIL 21, 2016 SHEET NO. TA000
NO.	DESCRIPTION	DATE																											
01	REVISION A	09.16.14																											
02	REVISION B	09.16.14																											
03	REVISION C	10.29.14																											
04	AV 100% DD FINAL REVISION	11.24.15																											
05	100% CD FOR CONSTRUCTION	03.25.16																											

GENERAL NOTES:

1. AV INTEGRATOR TO COORDINATE LOCATIONS AND INSTALLATION OF FLOOR BOXES, POKE THROUGH DEVICES, FLAT PANEL DISPLAYS, DISPLAY MOUNTS, CONTROL TABLE MOUNTS, INPUT/OUTPUT PANELS WITH ARCHITECT AND AE TEAM.
2. ALL FLOOR BOXES AND POKE THROUGH DEVICES ARE BEING PURCHASED BY THE OWNER AND INSTALLED BY THE ELECTRICAL CONTRACTOR. AV INTEGRATOR TO SUPPLY AND INSTALL THE INPUT/OUTPUT PLATES AND COVER FOR ALL FLOOR BOXES AND POKE THROUGH DEVICES. COORDINATE COVER FINISHES WITH ARCHITECT.

SHEET NOTES: (1)

1. ROUTE CONDUIT TO FPD-04 VIA MILLWORK
2. WALL MOUNT, WITH TILT ADJUST
3. TP-02 TABLET CONTROL DEVICE MOUNTED TO POLE MOUNT FIXED TO DEMO STATION SURFACE
4. RECESSED DISPLAY

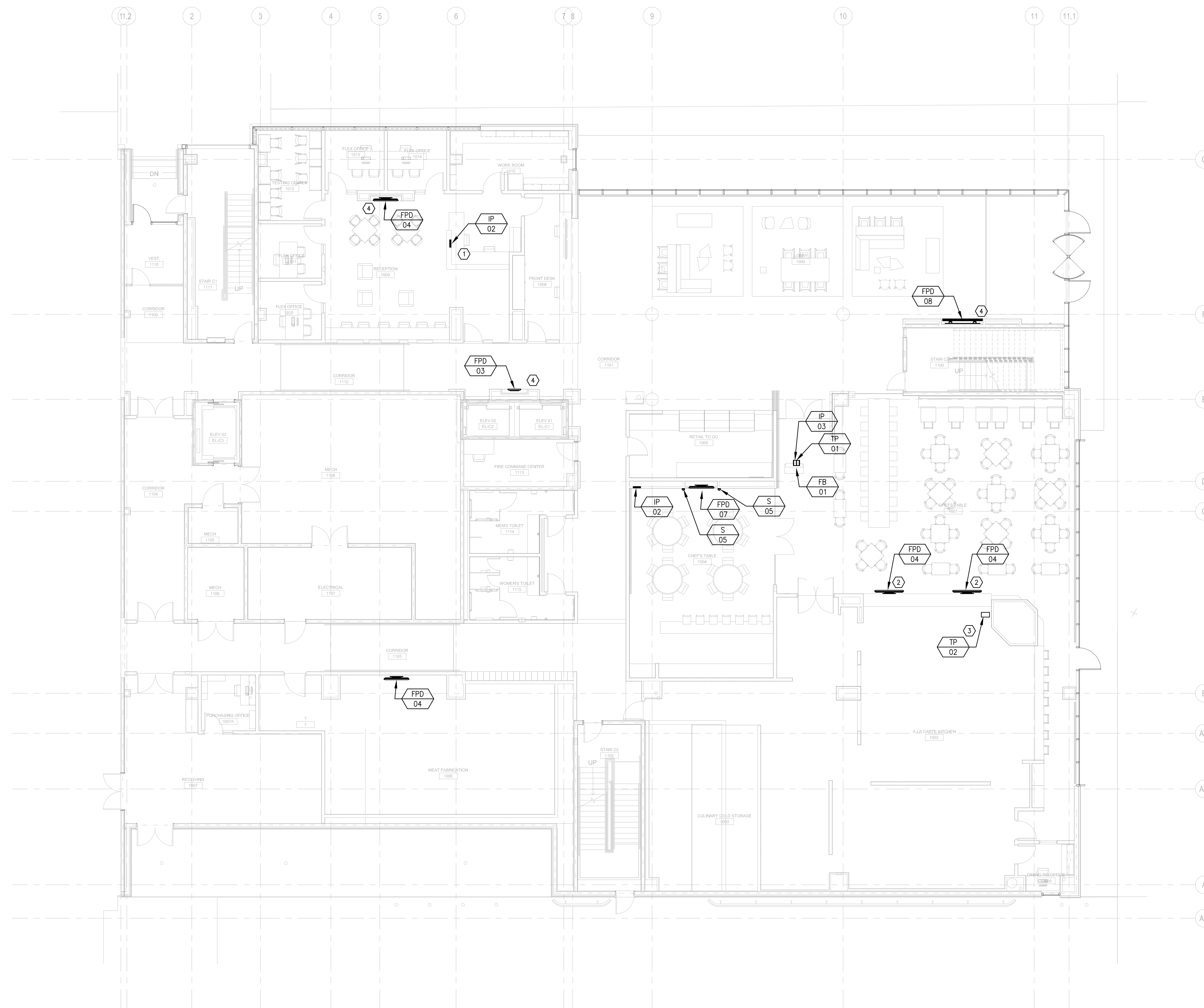

1 AUDIOVISUAL LEVEL 01 - FLOOR PLAN
1/8" = 1'-0"

NOTE: CONTRACTOR SHALL VERIFY ALL DIMENSIONS AND CONDITIONS AT JOB SITE AND BE FULLY RESPONSIBLE FOR SAME.

REVISIONS			DRAWN	PREPARED	100% CD FOR CONSTRUCTION				PROJECT NO.
NO.	DESCRIPTION	DATE	TL	RST	AUDIOVISUAL LEVEL 01				
01	REVISION A	09.16.14	TRACED	APPROVED	CITY CENTER CAMPUS JOLIET JUNIOR COLLEGE				DATE
02	REVISION B	09.16.14	TL	RST					APRIL 21, 2016
03	REVISION C	10.29.14	CHECKED	APPROVED					SHEET NO.
04	AV 100% DD FINAL REVISION	11.24.15	TL	RST					TA101
05	100% CD FOR CONSTRUCTION	03.25.16							
			 DEMONICA KEMPER ARCHITECTS 125 N. HALSTED STREET, SUITE 301 CHICAGO, IL 60661 P: 312.496.0000	 KJWW ENGINEERING 1100 WARRENVILLE ROAD, #400W NAPERVILLE, IL 60563 T: 312.559.4585	 E.F. WHITNEY, INC. 568 ANN STREET BIRMINGHAM, MI 48009 T: 248.644.0990	 SHEN MILSON WILKE LLC 2 N. RIVERSIDE PLAZA CHICAGO, IL 60606 T: 312.559.4585			

GENERAL NOTES:

1. AV INTEGRATOR TO COORDINATE LOCATIONS AND INSTALLATION OF FLOOR BOXES, POKE THROUGH DEVICES, FLAT PANEL DISPLAYS, DISPLAY MOUNTS, CONTROL TABLET MOUNTS, INPUT/OUTPUT PANELS WITH ARCHITECT AND AE TEAM.
2. ALL FLOOR BOXES AND POKE THROUGH DEVICES ARE BEING PURCHASED BY THE OWNER AND INSTALLED BY THE ELECTRICAL CONTRACTOR. AV INTEGRATOR TO SUPPLY AND INSTALL THE INPUT/OUTPUT PLATES AND COVER FOR ALL FLOOR BOXES AND POKE THROUGH DEVICES. COORDINATE COVER FINISHES WITH ARCHITECT.

SHEET NOTES: (1)

1. WALL MOUNT ABOVE DOORWAY(S)
2. "F" INDICATES FUTURE DEVICE
3. THREE FPD-02 DISPLAYS VERTICALLY STACKED
4. TP-02 TABLET CONTROL DEVICE MOUNTED TO POLE MOUNT FIXED TO DEMO STATION SURFACE

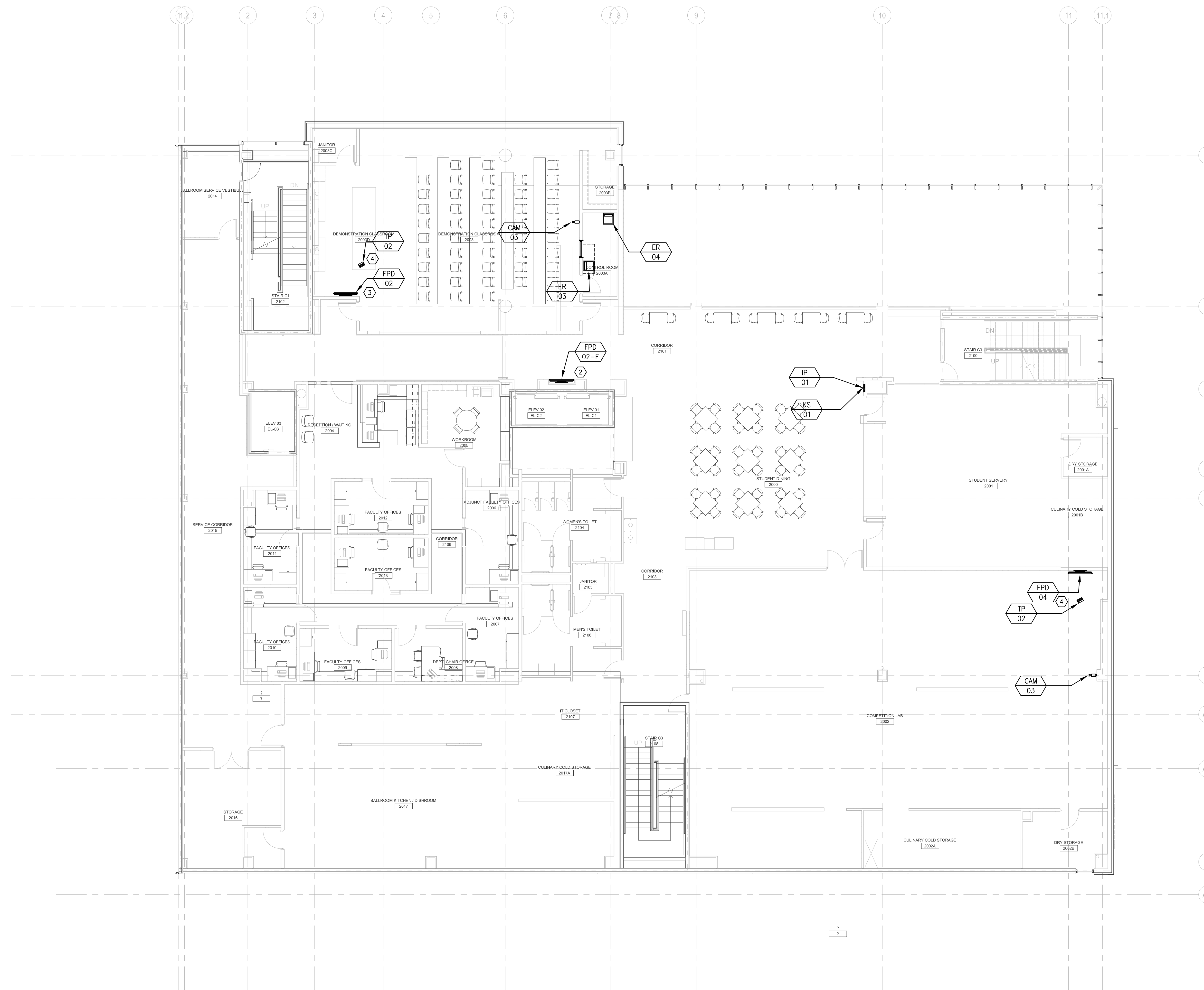

1 AUDIOVISUAL LEVEL 02 - FLOOR PLAN
1/8" = 1'-0"

NOTE: CONTRACTOR SHALL VERIFY ALL DIMENSIONS AND CONDITIONS AT JOB SITE AND BE FULLY RESPONSIBLE FOR SAME.

REVISIONS			DRAWN	PREPARED	100% CD FOR CONSTRUCTION				PROJECT NO.
NO.	DESCRIPTION	DATE	TL	RST	AUDIOVISUAL LEVEL 02				PROJECT NO.
01	REVISION A	09.16.14	TL	RST					DATE
02	REVISION B	09.16.14	TL	RST					APRIL 21, 2016
03	REVISION C	10.29.14	TL	RST					SHEET NO.
04	AV 100% DD FINAL REVISION	11.24.15	TL	RST					CITY CENTER CAMPUS
05	100% CD FOR CONSTRUCTION	03.25.16	TL	RST					JOLIET JUNIOR COLLEGE
			CHECKED	APPROVED					SHEET NO.
			TL	RST					TA102

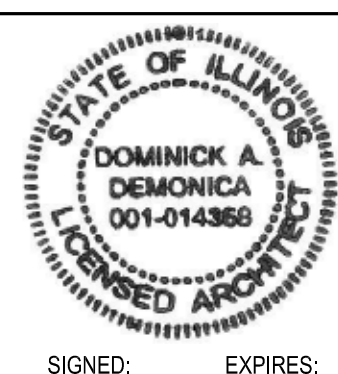

DKA DEMONICA KEMPER ARCHITECTS
125 N. HALSTED STREET, SUITE 301
CHICAGO, IL 60661
P: 312.496.0000

KJW KJWW ENGINEERING
1100 WARRENVILLE ROAD, #400W
NAPERVILLE, IL 60563
T: 312.559.4585

EFW E.F. WHITNEY, INC.
568 ANN STREET
BIRMINGHAM, MI 48009
T: 248.644.0990

SM&W SHEN MILSON WILKE
2 N. RIVERSIDE PLAZA
CHICAGO, IL 60606
T: 312.559.4585

GENERAL NOTES:

1. AV INTEGRATOR TO COORDINATE LOCATIONS AND INSTALLATION OF FLOOR BOXES, POKE THROUGH DEVICES, FLAT PANEL DISPLAYS, DISPLAY MOUNTS, CONTROL TABLE MOUNTS, INPUT/OUTPUT PANELS WITH ARCHITECT AND AE TEAM.
2. ALL FLOOR BOXES AND POKE THROUGH DEVICES ARE BEING PURCHASED BY THE OWNER AND INSTALLED BY THE ELECTRICAL CONTRACTOR. AV INTEGRATOR TO SUPPLY AND INSTALL THE INPUT/OUTPUT PLATES AND COVER FOR ALL FLOOR BOXES AND POKE THROUGH DEVICES. COORDINATE COVER FINISHES WITH ARCHITECT.

SHEET NOTES: (F)

1. WALL MOUNTED MANUAL PROJECTION SCREEN
2. "F" INDICATES FUTURE DEVICE
3. RECESSED DISPLAY

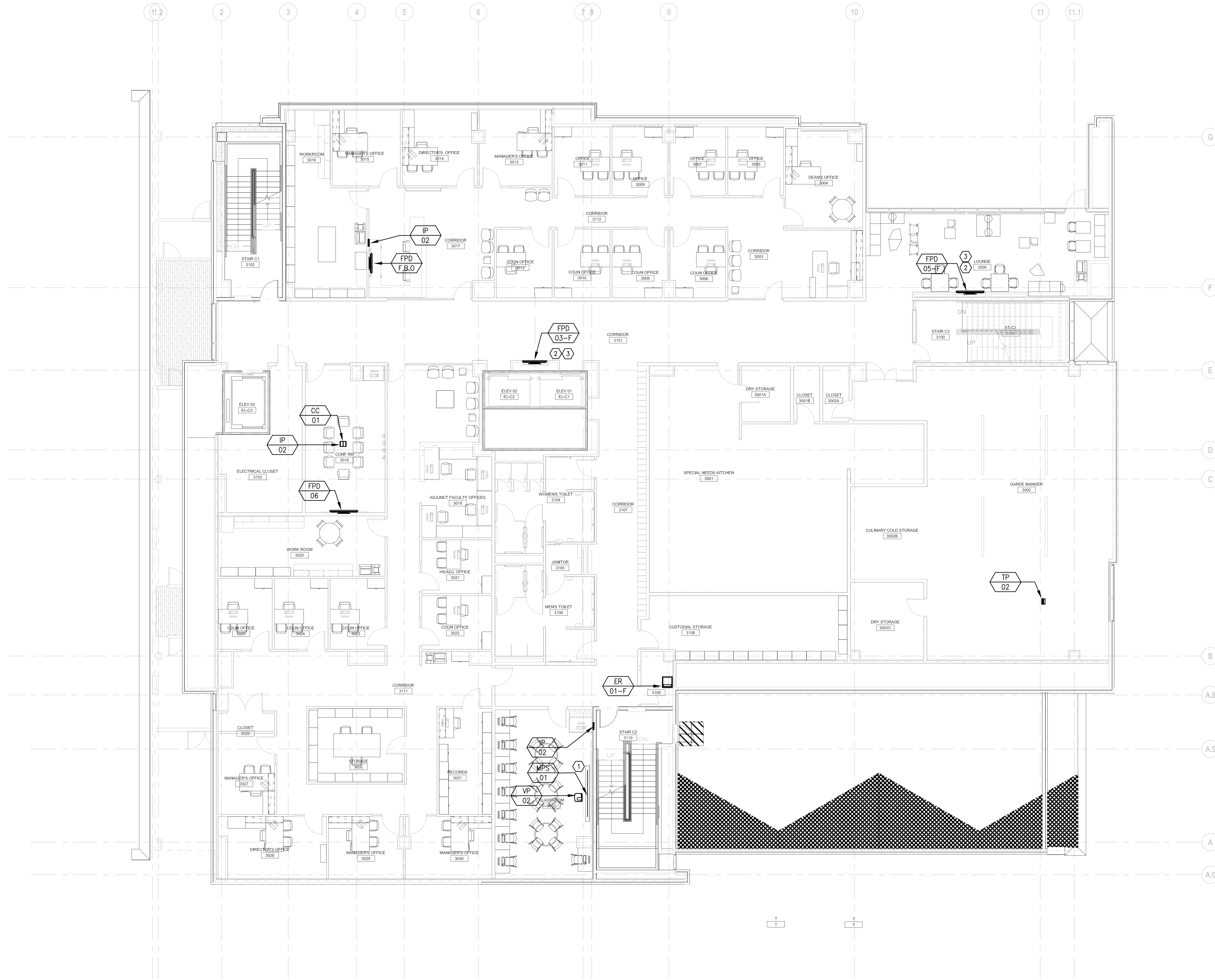

1 AUDIOVISUAL LEVEL 03 - FLOOR PLAN
1/8" = 1'-0"

NOTE: CONTRACTOR SHALL VERIFY ALL DIMENSIONS AND CONDITIONS AT JOB SITE AND BE FULLY RESPONSIBLE FOR SAME.

REVISIONS			DRAWN	PREPARED	100% CD FOR CONSTRUCTION				PROJECT NO.
NO.	DESCRIPTION	DATE	TL	RST	AUDIOVISUAL LEVEL 03				
01	REVISION A	09.16.14	TL	RST					DATE
02	REVISION B	09.16.14	TL	RST					APRIL 21, 2016
03	REVISION C	10.29.14	TL	RST					SHEET NO.
04	AV 100% DD FINAL REVISION	11.24.15	TL	RST					CITY CENTER CAMPUS
05	100% CD FOR CONSTRUCTION	03.25.16	TL	RST					JOLIET JUNIOR COLLEGE
			CHECKED	APPROVED					TA103

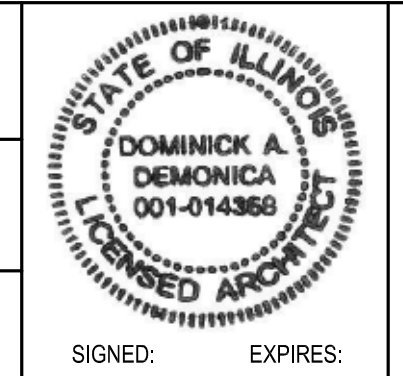

DKA DEMONICA KEMPER ARCHITECTS
125 N. HALSTED STREET, SUITE 301
CHICAGO, IL 60661
P: 312.496.0000

KJW KJWW ENGINEERING
1100 WARRENVILLE ROAD, #400W
NAPERVILLE, IL 60563
T: 312.559.4585

EFW E.F. WHITNEY, INC.
568 ANN STREET
BIRMINGHAM, MI 48009
T: 248.644.0990

SM&W SHEN MILSON WILKE
2 N. RIVERSIDE PLAZA
CHICAGO, IL 60606
T: 312.559.4585

GENERAL NOTES:

1. AV INTEGRATOR TO COORDINATE LOCATIONS AND INSTALLATION OF FLOOR BOXES, POKE THROUGH DEVICES, FLAT PANEL DISPLAYS, DISPLAY MOUNTS, CONTROL TABLET MOUNTS, INPUT/OUTPUT PANELS WITH ARCHITECT AND AE TEAM.
2. ALL FLOOR BOXES AND POKE THROUGH DEVICES ARE BEING PURCHASED BY THE OWNER AND INSTALLED BY THE ELECTRICAL CONTRACTOR: AV INTEGRATOR TO SUPPLY AND INSTALL THE INPUT/OUTPUT PLATES AND COVER FOR ALL FLOOR BOXES AND POKE THROUGH DEVICES. COORDINATE COVER FINISHES WITH ARCHITECT.

SHEET NOTES: (7)

1. WALL MOUNTED MANUAL PROJECTION SCREEN
2. "F" INDICATED ON FPD FLAGS AND ER FLAGS INDICATES FUTURE DEVICE
3. RECESSED DISPLAY

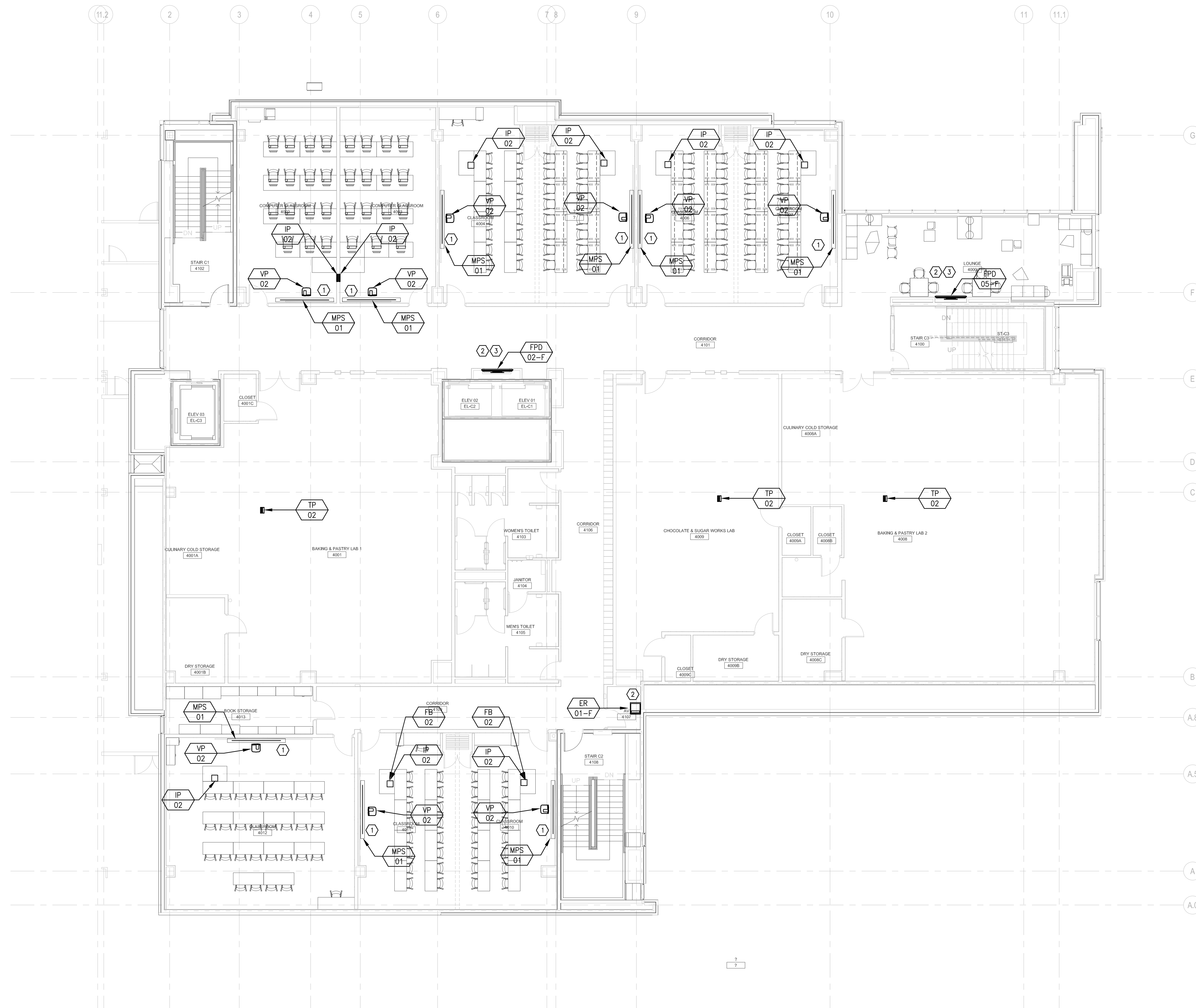

1 AUDIOVISUAL LEVEL 04 - FLOOR PLAN
1/8" = 1'-0"

NOTE: CONTRACTOR SHALL VERIFY ALL DIMENSIONS AND CONDITIONS AT JOB SITE AND BE FULLY RESPONSIBLE FOR SAME.

REVISIONS			DRAWN	PREPARED	100% CD FOR CONSTRUCTION				PROJECT NO.
NO.	DESCRIPTION	DATE	TL	RST	AUDIOVISUAL LEVEL 04				
01	REVISION A	09.16.14	TL	RST					DATE
02	REVISION B	09.16.14	TL	RST					APRIL 21, 2016
03	REVISION C	10.29.14	TL	RST					SHEET NO.
04	AV 100% DD FINAL REVISION	11.24.15	TL	RST					CITY CENTER CAMPUS
05	100% CD FOR CONSTRUCTION	03.25.16	TL	RST					JOLIET JUNIOR COLLEGE
									TA104

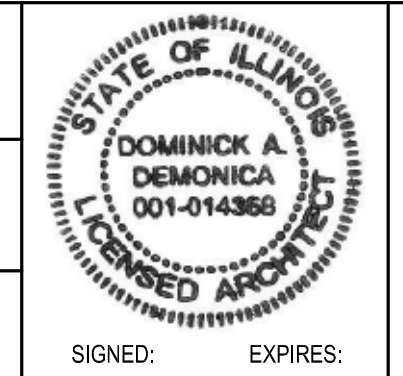

DKA DEMONICA KEMPER ARCHITECTS
125 N. HALSTED STREET, SUITE 301
CHICAGO, IL 60661
P: 312.496.0000

KJW KJWW ENGINEERING
1100 WARRENVILLE ROAD, #400W
NAPERVILLE, IL 60563
T: 212.559.4585

EFW E.F. WHITNEY, INC.
568 ANN STREET
BIRMINGHAM, MI 48009
T: 248.644.0990

SM&W SHEN MILSOM WILKE LLC
2 N. RIVERSIDE PLAZA
CHICAGO, IL 60606
T: 312.559.4585

GENERAL NOTES:

1. AV INTEGRATOR TO COORDINATE LOCATIONS AND INSTALLATION OF FLOOR BOXES, POKE THROUGH DEVICES, FLAT PANEL DISPLAYS, DISPLAY MOUNTS, CONTROL TABLET MOUNTS, INPUT/OUTPUT PANELS WITH ARCHITECT AND AE TEAM.
2. ALL FLOOR BOXES AND POKE THROUGH DEVICES ARE BEING PURCHASED BY THE OWNER AND INSTALLED BY THE ELECTRICAL CONTRACTOR. AV INTEGRATOR TO SUPPLY AND INSTALL THE INPUT/OUTPUT PLATES AND COVER FOR ALL FLOOR BOXES AND POKE THROUGH DEVICES. COORDINATE COVER FINISHES WITH ARCHITECT.

SHEET NOTES: (1)

1. WALL MOUNTED MANUAL PROJECTION SCREEN
2. CEILING MOUNTED MANUAL PROJECTION SCREEN
3. "F" INDICATED ON FPD FLAGS INDICATES FUTURE DEVICE

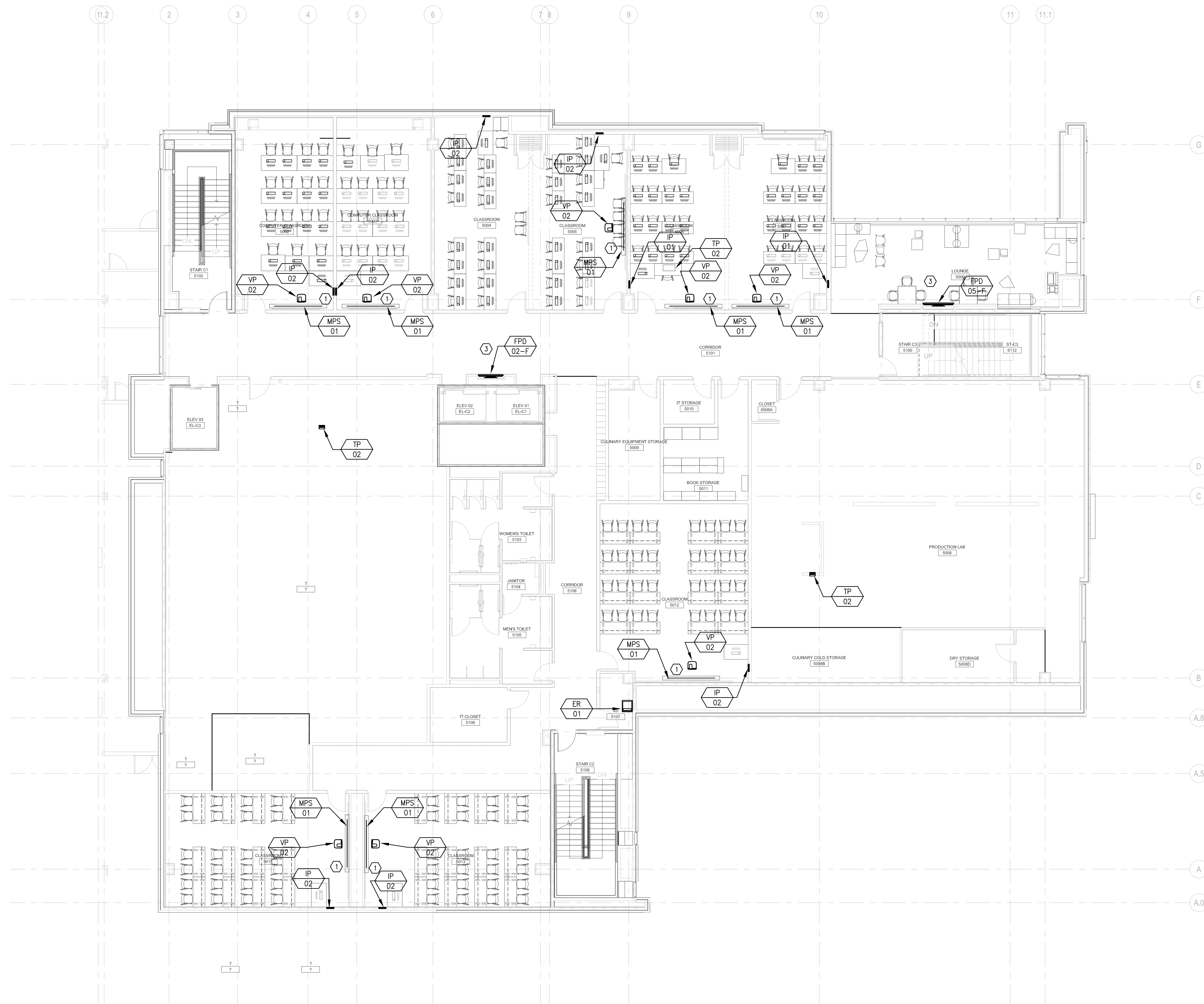

1 AUDIOVISUAL LEVEL 05 - FLOOR PLAN
1/8" = 1'-0"

NOTE: CONTRACTOR SHALL VERIFY ALL DIMENSIONS AND CONDITIONS AT JOB SITE AND BE FULLY RESPONSIBLE FOR SAME.

REVISIONS			DRAWN	PREPARED	100% CD FOR CONSTRUCTION				PROJECT NO.	
NO.	DESCRIPTION	DATE	TL	RST	AUDIOVISUAL LEVEL 05				PROJECT NO.	
01	REVISION A	09.16.14	TRACED	APPROVED					DATE	
02	REVISION B	09.16.14	TL	RST					APRIL 21, 2016	
03	REVISION C	10.29.14							SHEET NO.	
04	AV 100% DD FINAL REVISION	11.24.15							CITY CENTER CAMPUS	
05	100% CD FOR CONSTRUCTION	03.25.16	CHECKED	APPROVED					JOLIET JUNIOR COLLEGE	
			TL	RST					TA105	



DKA DEMONICK KEMPER ARCHITECTS
125 N. HALSTED STREET, SUITE 301
CHICAGO, IL 60661
P: 312.496.0000

KJWW KJWW ENGINEERING
1100 WARRENVILLE ROAD, #400W
NAPERVILLE, IL 60563
T: 312.559.4585

EFW E.F. WHITNEY, INC.
568 ANN STREET
BIRMINGHAM, MI 48009
T: 248.644.0990

SM&W SHEN MILSOM WILKE LLC
2 N. RIVERSIDE PLAZA
CHICAGO, IL 60606
T: 312.559.4585

GENERAL NOTES:

1. AV INTEGRATOR TO COORDINATE LOCATIONS AND INSTALLATION OF FLOOR BOXES, POKE THROUGH DEVICES, FLAT PANEL DISPLAYS, DISPLAY MOUNTS, CONTROL TABLE MOUNTS, INPUT/OUTPUT PANELS WITH ARCHITECT AND AE TEAM.
2. ALL FLOOR BOXES AND POKE THROUGH DEVICES ARE BEING PURCHASED BY THE OWNER AND INSTALLED BY THE ELECTRICAL CONTRACTOR. AV INTEGRATOR TO SUPPLY AND INSTALL THE INPUT/OUTPUT PLATES AND COVER FOR ALL FLOOR BOXES AND POKE THROUGH DEVICES. COORDINATE COVER FINISHES WITH ARCHITECT.

SHEET NOTES: (1)

1. WALL MOUNTED MANUAL PROJECTION SCREEN
2. CEILING MOUNT TIGHT TO CEILING WITH TILT ADJUSTMENT
3. "F" INDICATED ON FPD FLAGS INDICATES FUTURE DEVICE

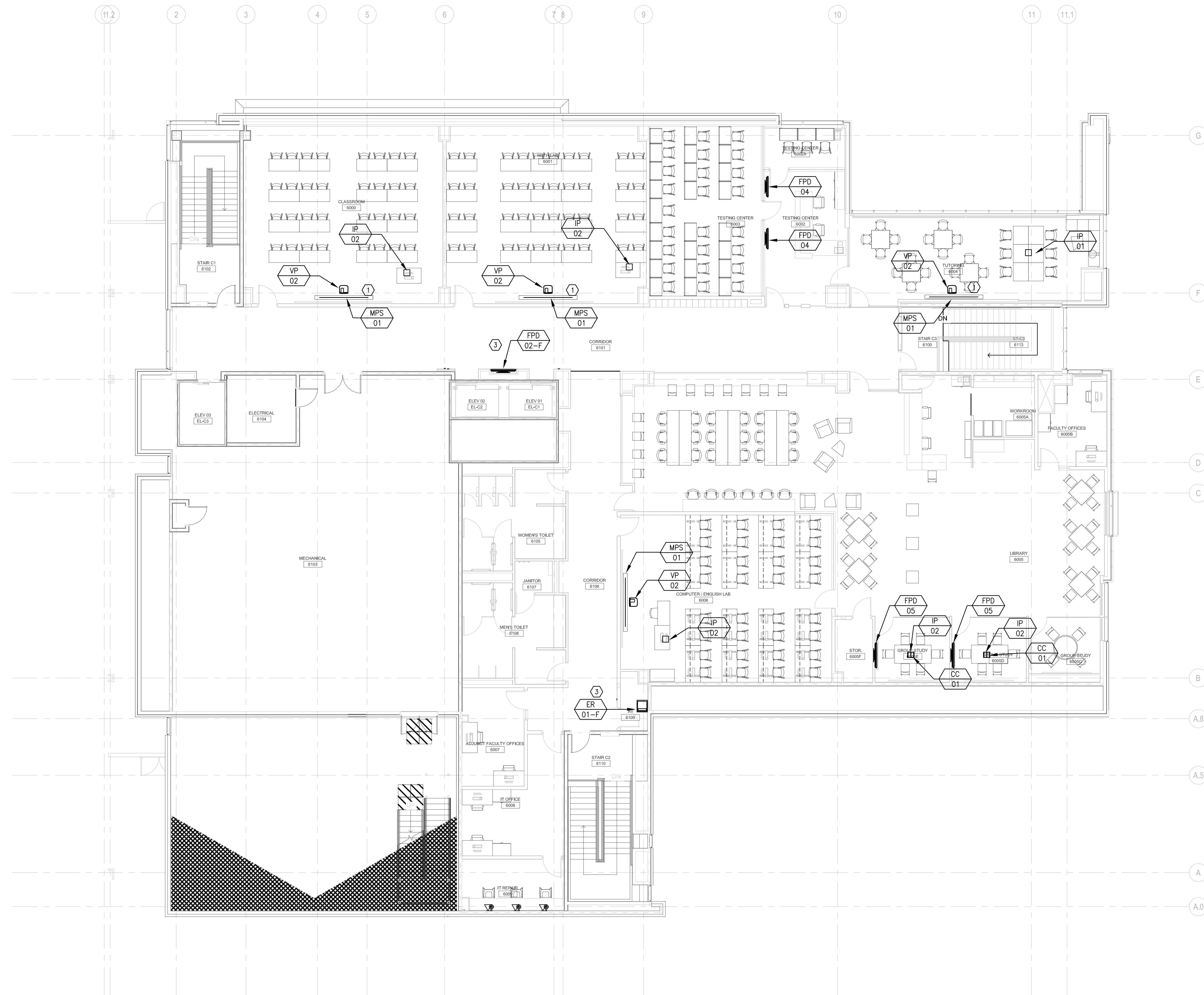

1 AUDIOVISUAL LEVEL 06 - FLOOR PLAN
1/8" = 1'-0"

NOTE: CONTRACTOR SHALL VERIFY ALL DIMENSIONS AND CONDITIONS AT JOB SITE AND BE FULLY RESPONSIBLE FOR SAME.

REVISIONS <table border="1"> <thead> <tr> <th>NO.</th> <th>DESCRIPTION</th> <th>DATE</th> </tr> </thead> <tbody> <tr> <td>01</td> <td>REVISION A</td> <td>09.16.14</td> </tr> <tr> <td>02</td> <td>REVISION B</td> <td>09.16.14</td> </tr> <tr> <td>03</td> <td>REVISION C</td> <td>10.29.14</td> </tr> <tr> <td>04</td> <td>AV 100% DD FINAL REVISION</td> <td>11.24.15</td> </tr> <tr> <td>05</td> <td>100% CD FOR CONSTRUCTION</td> <td>03.25.16</td> </tr> </tbody> </table>		NO.	DESCRIPTION	DATE	01	REVISION A	09.16.14	02	REVISION B	09.16.14	03	REVISION C	10.29.14	04	AV 100% DD FINAL REVISION	11.24.15	05	100% CD FOR CONSTRUCTION	03.25.16	DRAWN: TL PREPARED: RST TRACED: TL APPROVED: RST CHECKED: TL APPROVED: RST		DEMONICA KEMPER ARCHITECTS 125 N. HALSTED STREET, SUITE 301 CHICAGO, IL 60661 P: 312.496.0000	KJWW ENGINEERING 1100 WARRENVILLE ROAD, #400W NAPERVILLE, IL 60563 T: 312.559.4585	E.F. WHITNEY, INC. 568 ANN STREET BIRMINGHAM, MI 48009 T: 248.644.0990	SHEN MILSON WILKE 2 N. RIVERSIDE PLAZA CHICAGO, IL 60606 T: 312.559.4585	100% CD FOR CONSTRUCTION AUDIOVISUAL LEVEL 06 CITY CENTER CAMPUS JOLIET JUNIOR COLLEGE	PROJECT NO. DATE: APRIL 21, 2016 SHEET NO. TA106
NO.	DESCRIPTION	DATE																									
01	REVISION A	09.16.14																									
02	REVISION B	09.16.14																									
03	REVISION C	10.29.14																									
04	AV 100% DD FINAL REVISION	11.24.15																									
05	100% CD FOR CONSTRUCTION	03.25.16																									

GENERAL NOTES:

1. AV INTEGRATOR TO COORDINATE LOCATIONS AND INSTALLATION OF FLOOR BOXES, POKE THROUGH DEVICES, FLAT PANEL DISPLAYS, DISPLAY MOUNTS, CONTROL TABLET MOUNTS, INPUT/OUTPUT PANELS WITH ARCHITECT AND AE TEAM.
2. ALL FLOOR BOXES AND POKE THROUGH DEVICES ARE BEING PURCHASED BY THE OWNER AND INSTALLED BY THE ELECTRICAL CONTRACTOR: AV INTEGRATOR TO SUPPLY AND INSTALL THE INPUT/OUTPUT PLATES AND COVER FOR ALL FLOOR BOXES AND POKE THROUGH DEVICES. COORDINATE COVER FINISHES WITH ARCHITECT.

SHEET NOTES: (1)

1. CEILING MOUNT TIGHT AGAINST CEILING WITH TILE ADJUSTMENT; VERIFY MOUNTING VS DOOR CLEARANCE, WITH TILT ADJUST

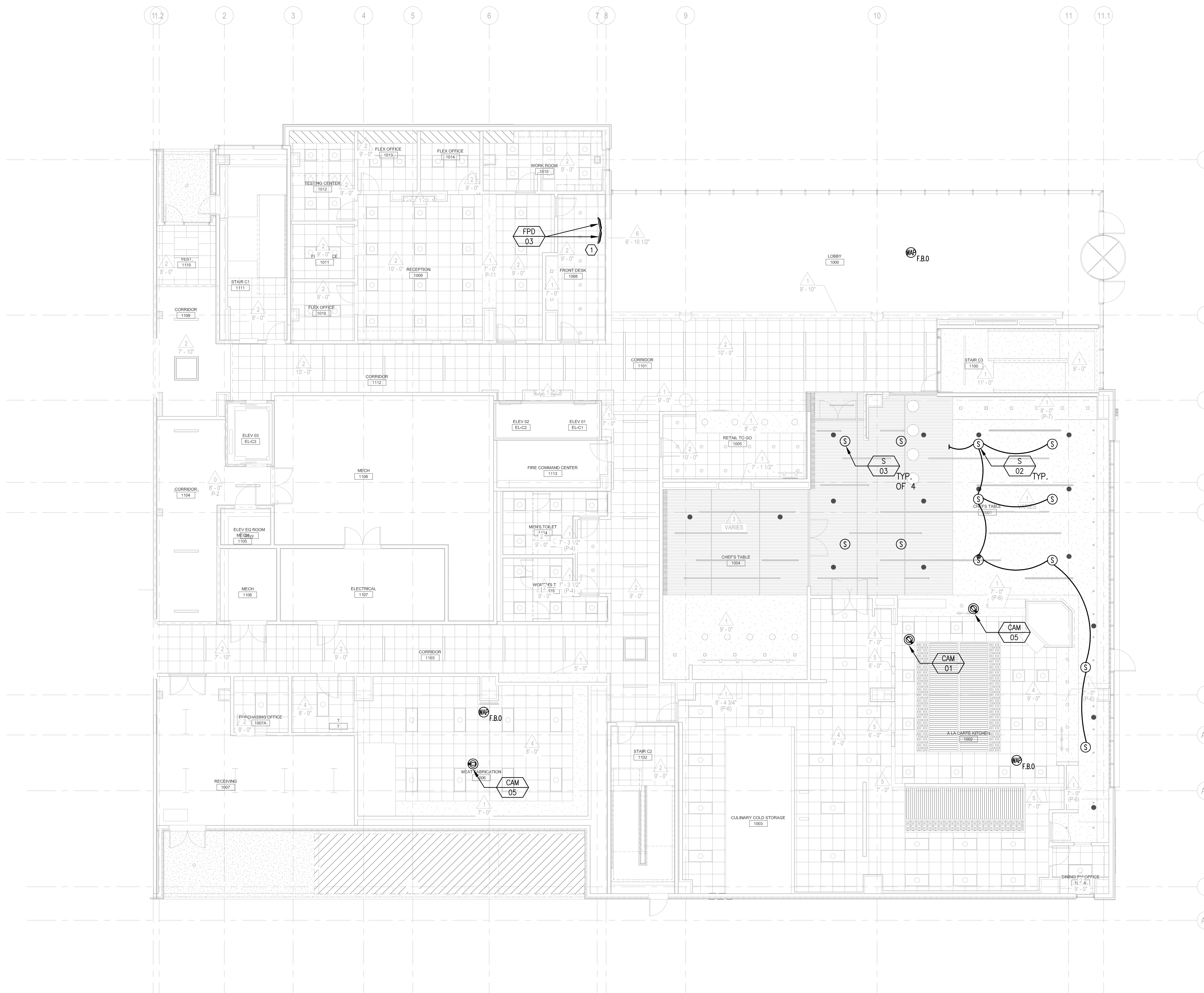

1 AUDIOVISUAL LEVEL 01 - RCP
1/8" = 1'-0"

NOTE: CONTRACTOR SHALL VERIFY ALL DIMENSIONS AND CONDITIONS AT JOB SITE AND BE FULLY RESPONSIBLE FOR SAME.

REVISIONS			DRAWN	PREPARED	100% CD FOR CONSTRUCTION				PROJECT NO.	
NO.	DESCRIPTION	DATE	TL	RST	AUDIOVISUAL RCP LEVEL 01				TA201	
01	REVISION A	09.16.14	TRACED	APPROVED					DATE	
02	REVISION B	09.16.14	TL	RST					APRIL 21, 2016	
03	REVISION C	10.29.14	CHECKED	APPROVED					SHEET NO.	
04	AV 100% DD FINAL REVISION	11.24.15	TL	RST					CITY CENTER CAMPUS	
05	100% CD FOR CONSTRUCTION	03.25.16							JOLIET JUNIOR COLLEGE	
									PROJECT NO.	
					125 N. HALSTED STREET, SUITE 301, CHICAGO, IL 60661 P: 312.496.0000 1100 WARRENVILLE ROAD, #400W, NAPERVILLE, IL 60563 T: 312.559.4585 568 ANN STREET, BIRMINGHAM, MI 48009 T: 248.644.0990 2 N. RIVERSIDE PLAZA, CHICAGO, IL 60606 T: 312.559.4585				DATE	
									APRIL 21, 2016	
									SHEET NO.	
									TA201	

GENERAL NOTES:

1. AV INTEGRATOR TO COORDINATE LOCATIONS AND INSTALLATION OF FLOOR BOXES, POKE THROUGH DEVICES, FLAT PANEL DISPLAYS, DISPLAY MOUNTS, CONTROL TABLE MOUNTS, INPUT/OUTPUT PANELS WITH ARCHITECT AND AE TEAM.
2. ALL FLOOR BOXES AND POKE THROUGH DEVICES ARE BEING PURCHASED BY THE OWNER AND INSTALLED BY THE ELECTRICAL CONTRACTOR. AV INTEGRATOR TO SUPPLY AND INSTALL THE INPUT/OUTPUT PLATES AND COVER FOR ALL FLOOR BOXES AND POKE THROUGH DEVICES. COORDINATE COVER FINISHES WITH ARCHITECT.

SHEET NOTES: (A)

1. CEILING POLE MOUNTED

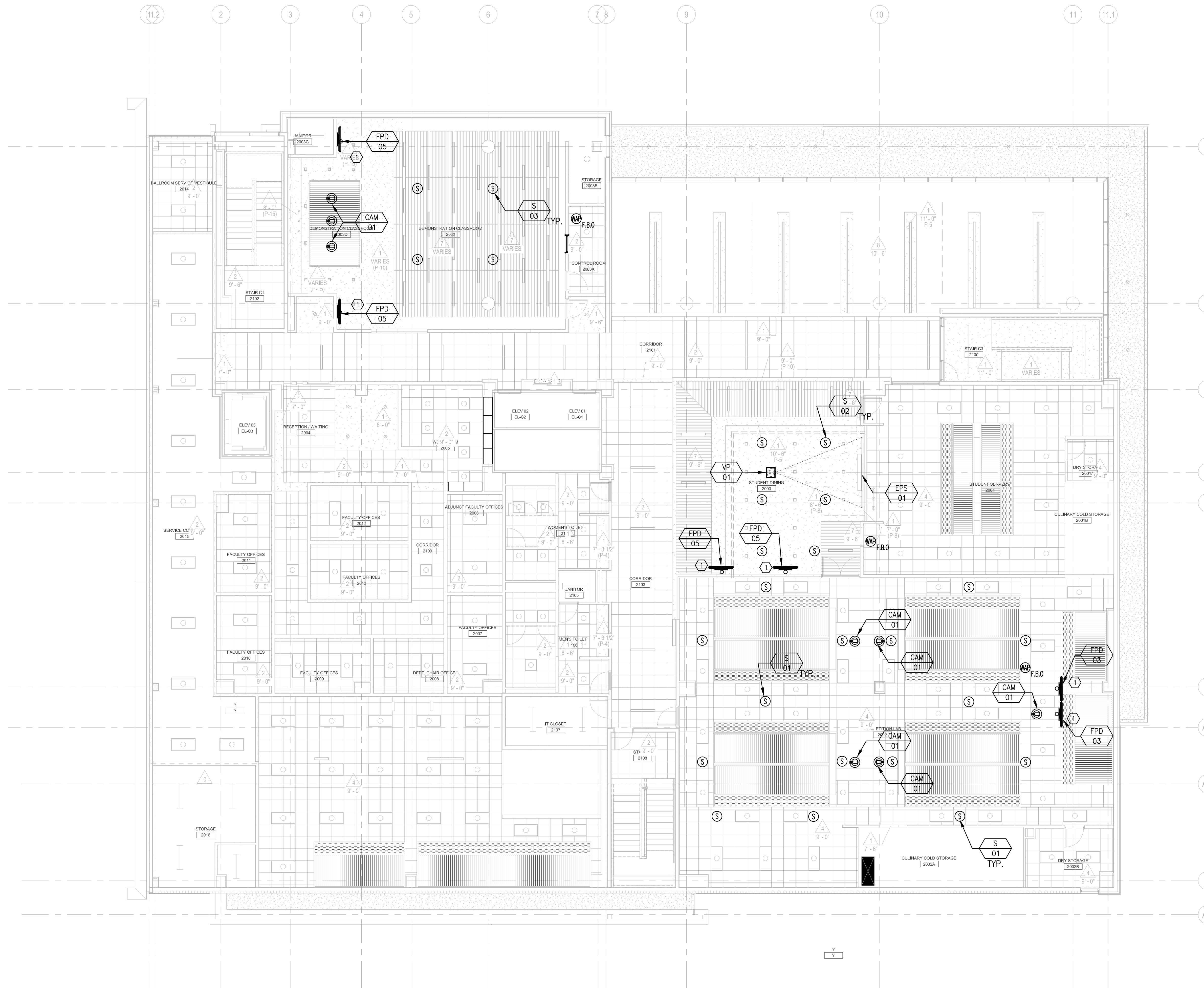

1 AUDIOVISUAL LEVEL 02 - RCP
1/8" = 1'-0"

NOTE: CONTRACTOR SHALL VERIFY ALL DIMENSIONS AND CONDITIONS AT JOB SITE AND BE FULLY RESPONSIBLE FOR SAME.

REVISIONS		
NO.	DESCRIPTION	DATE
01	REVISION A	09.16.14
02	REVISION B	09.16.14
03	REVISION C	10.29.14
04	AV 100% DD FINAL REVISION	11.24.15
05	100% CD FOR CONSTRUCTION	03.25.16

DRAWN	PREPARED
TL	RST
TRACED	APPROVED
TL	RST
CHECKED	APPROVED
TL	RST

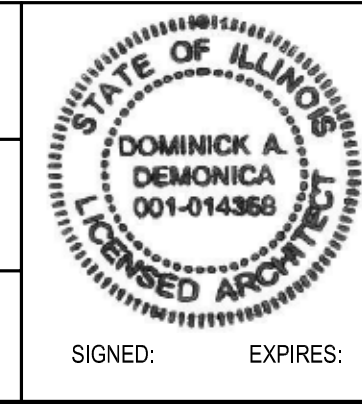

dkA DEMONICA
KEMPER
ARCHITECTS
125 N. HALSTED STREET,
SUITE 301
CHICAGO, IL 60661
P: 312.496.0000

KJW KJWW
ENGINEERING
1100 WARRENVILLE
ROAD, #400W
NAPERVILLE, IL 60563
T: 312.559.4585

EFW E.F. WHITNEY,
INC.
568 ANN STREET
BIRMINGHAM, MI 48009
T: 248.644.0990

SM&W SHEN MILSOM
WILKE LLC
2 N. RIVERSIDE PLAZA
CHICAGO, IL 60606
T: 312.559.4585

100% CD FOR CONSTRUCTION		PROJECT NO.
AUDIOVISUAL RCP LEVEL 02		DATE APRIL 21, 2016
CITY CENTER CAMPUS		SHEET NO.
JOLIET JUNIOR COLLEGE		TA202

GENERAL NOTES:

1. AV INTEGRATOR TO COORDINATE LOCATIONS AND INSTALLATION OF FLOOR BOXES, POKE THROUGH DEVICES, FLAT PANEL DISPLAYS, DISPLAY MOUNTS, CONTROL TABLE MOUNTS, INPUT/OUTPUT PANELS WITH ARCHITECT AND AE TEAM.
2. ALL FLOOR BOXES AND POKE THROUGH DEVICES ARE BEING PURCHASED BY THE OWNER AND INSTALLED BY THE ELECTRICAL CONTRACTOR. AV INTEGRATOR TO SUPPLY AND INSTALL THE INPUT/OUTPUT PLATES AND COVER FOR ALL FLOOR BOXES AND POKE THROUGH DEVICES. COORDINATE COVER FINISHES WITH ARCHITECT.

SHEET NOTES: (1)

1. CEILING POLE MOUNTED
2. CEILING POLE MOUNTED ON DUAL DISPLAY MOUNT

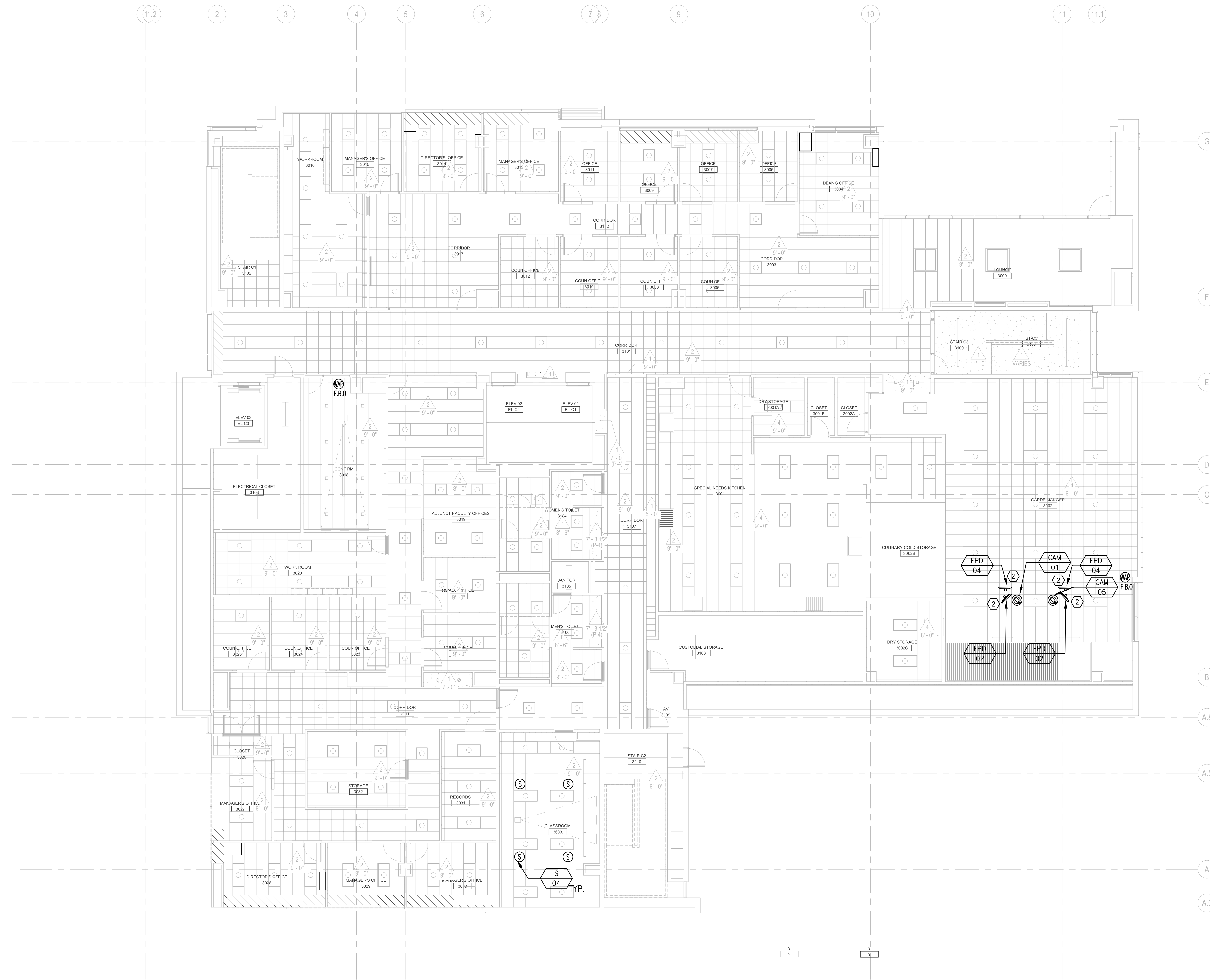

1 AUDIOVISUAL LEVEL 03 - RCP
1/8" = 1'-0"

NOTE: CONTRACTOR SHALL VERIFY ALL DIMENSIONS AND CONDITIONS AT JOB SITE AND BE FULLY RESPONSIBLE FOR SAME.

REVISIONS			DRAWN	PREPARED	100% CD FOR CONSTRUCTION				PROJECT NO.	
NO.	DESCRIPTION	DATE	TL	RST	AUDIOVISUAL RCP LEVEL 03					
01	REVISION A	09.16.14	TRACED	APPROVED	DEMONICA KEMPER ARCHITECTS 125 N. HALSTED STREET, SUITE 301 CHICAGO, IL 60661 P: 312.496.0000				DATE	
02	REVISION B	09.16.14	TL	RST					KJWW ENGINEERING 1100 WARRENVILLE ROAD, #400W NAPERVILLE, IL 60563 T: 312.559.4585	APRIL 21, 2016
03	REVISION C	10.29.14							E.F. WHITNEY, INC. 568 ANN STREET BIRMINGHAM, MI 48009 T: 248.644.0990	SHEET NO.
04	AV 100% DD FINAL REVISION	11.24.15							SHEN MILSOM WILKE LLC 2 N. RIVERSIDE PLAZA CHICAGO, IL 60606 T: 312.559.4585	TA203
05	100% CD FOR CONSTRUCTION	03.25.16	CHECKED	APPROVED						
			TL	RST						

GENERAL NOTES:

1. AV INTEGRATOR TO COORDINATE LOCATIONS AND INSTALLATION OF FLOOR BOXES, POKE THROUGH DEVICES, FLAT PANEL DISPLAYS, DISPLAY MOUNTS, CONTROL TABLET MOUNTS, INPUT/OUTPUT PANELS WITH ARCHITECT AND AE TEAM.
2. ALL FLOOR BOXES AND POKE THROUGH DEVICES ARE BEING PURCHASED BY THE OWNER AND INSTALLED BY THE ELECTRICAL CONTRACTOR. AV INTEGRATOR TO SUPPLY AND INSTALL THE INPUT/OUTPUT PLATES AND COVER FOR ALL FLOOR BOXES AND POKE THROUGH DEVICES. COORDINATE COVER FINISHES WITH ARCHITECT.

SHEET NOTES: (1)

1. CEILING POLE MOUNTED DISPLAY
2. MOUNTED ON VENT HOOD
3. DUPLICATE AV SYSTEM IN PRODUCTION LAB 5008 AND PLACE IN 5001 (ADD ALTERNATE ACCEPTED)
4. CEILING MOUNTED MANUAL PROJECTION SCREEN

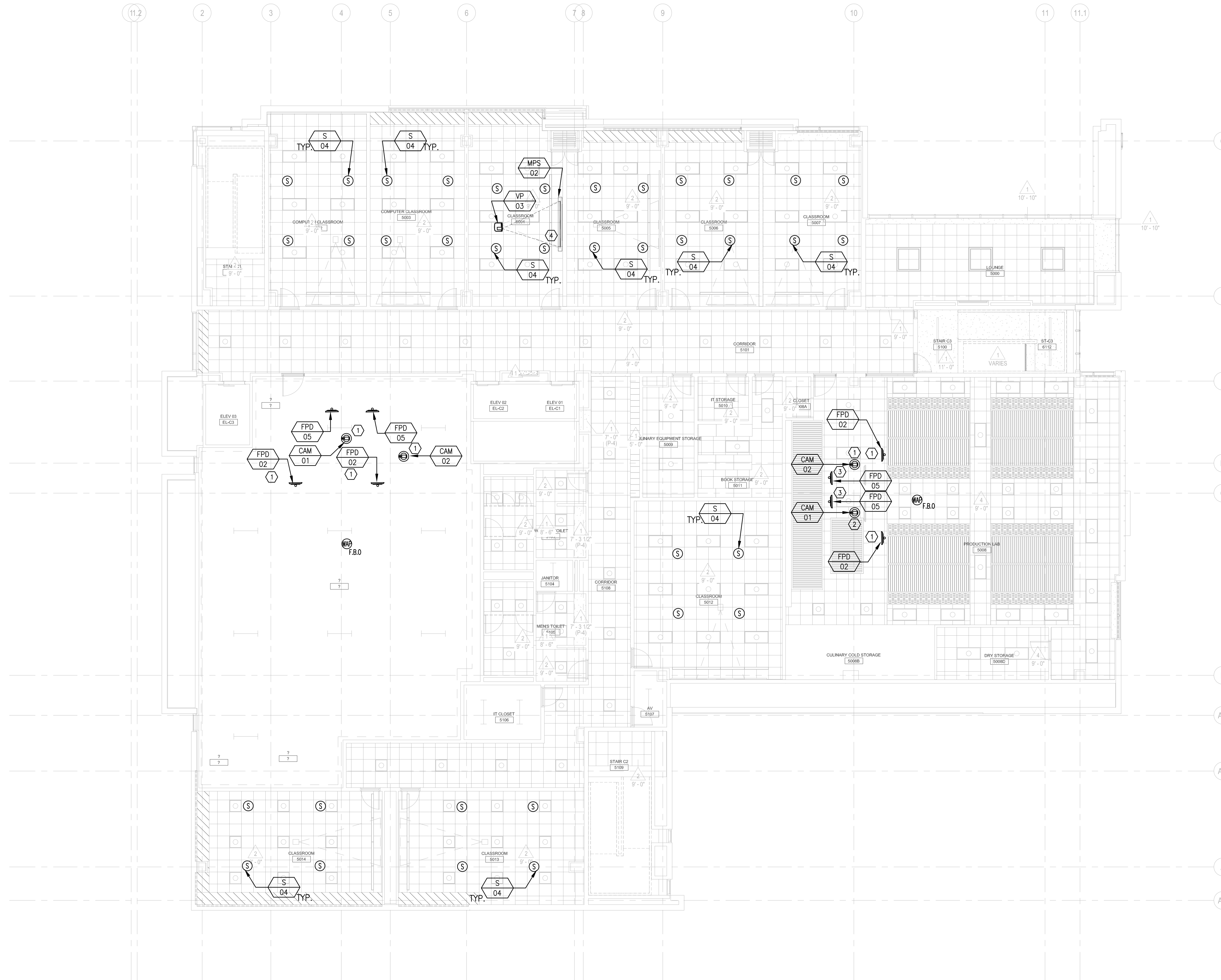

1 AUDIOVISUAL LEVEL 05 - RCP
1/8" = 1'-0"

NOTE: CONTRACTOR SHALL VERIFY ALL DIMENSIONS AND CONDITIONS AT JOB SITE AND BE FULLY RESPONSIBLE FOR SAME.

REVISIONS			DRAWN	PREPARED	100% CD FOR CONSTRUCTION				AUDIOVISUAL RCP LEVEL 05		PROJECT NO.
NO.	DESCRIPTION	DATE	TL	RST					CITY CENTER CAMPUS JOLIET JUNIOR COLLEGE		DATE
01	REVISION A	09.16.14	TL	RST							APRIL 21, 2016
02	REVISION B	09.16.14	TL	RST							SHEET NO.
03	REVISION C	10.29.14	TL	RST							TA205
04	AV 100% DD FINAL REVISION	11.24.15	TL	RST							
05	100% CD FOR CONSTRUCTION	03.25.16	TL	RST							
DEMONICA KEMPER ARCHITECTS 125 N. HALSTED STREET, SUITE 301 CHICAGO, IL 60661 P: 312.496.0000			KJWW ENGINEERING 1100 WARRENVILLE ROAD, #400W NAPERVILLE, IL 60563 T: 312.559.4585		E.F. WHITNEY, INC. 568 ANN STREET BIRMINGHAM, MI 48009 T: 248.644.0990		SHEN MILSON WILKE 2 N. RIVERSIDE PLAZA CHICAGO, IL 60606 T: 312.559.4585				

GENERAL NOTES:

1. AV INTEGRATOR TO COORDINATE LOCATIONS AND INSTALLATION OF FLOOR BOXES, POKE THROUGH DEVICES, FLAT PANEL DISPLAYS, DISPLAY MOUNTS, CONTROL TABLE MOUNTS, INPUT/OUTPUT PANELS WITH ARCHITECT AND AE TEAM.
2. ALL FLOOR BOXES AND POKE THROUGH DEVICES ARE BEING PURCHASED BY THE OWNER AND INSTALLED BY THE ELECTRICAL CONTRACTOR. AV INTEGRATOR TO SUPPLY AND INSTALL THE INPUT/OUTPUT PLATES AND COVER FOR ALL FLOOR BOXES AND POKE THROUGH DEVICES. COORDINATE COVER FINISHES WITH ARCHITECT.

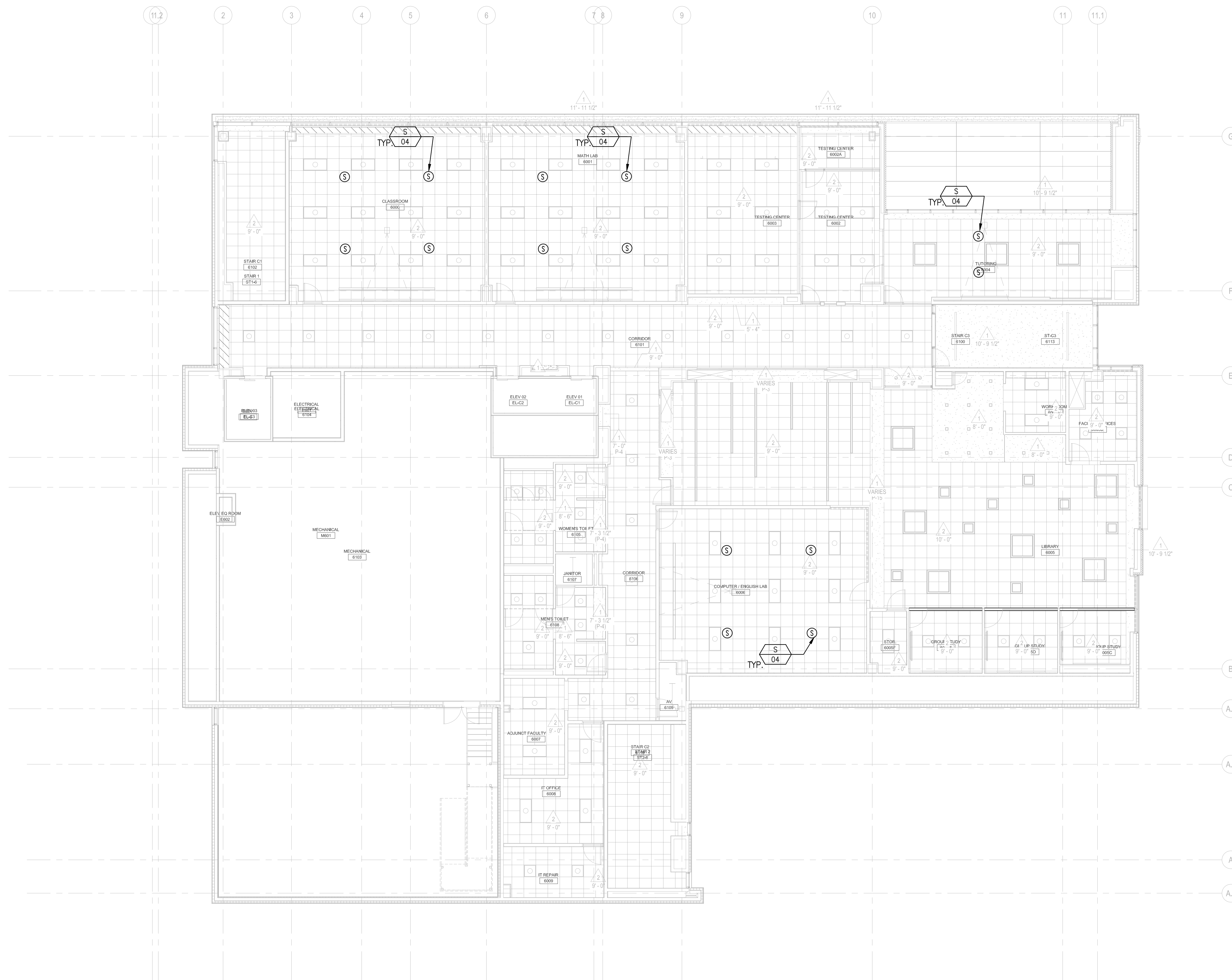

1 AUDIOVISUAL LEVEL 06 - RCP
1/8" = 1'-0"

NOTE: CONTRACTOR SHALL VERIFY ALL DIMENSIONS AND CONDITIONS AT JOB SITE AND BE FULLY RESPONSIBLE FOR SAME.

REVISIONS <table border="1"> <thead> <tr> <th>NO.</th> <th>DESCRIPTION</th> <th>DATE</th> </tr> </thead> <tbody> <tr> <td>01</td> <td>REVISION A</td> <td>09.16.14</td> </tr> <tr> <td>02</td> <td>REVISION B</td> <td>09.16.14</td> </tr> <tr> <td>03</td> <td>REVISION C</td> <td>10.29.14</td> </tr> <tr> <td>04</td> <td>AV 100% DD FINAL REVISION</td> <td>11.24.15</td> </tr> <tr> <td>05</td> <td>100% CD FOR CONSTRUCTION</td> <td>03.25.16</td> </tr> </tbody> </table>			NO.	DESCRIPTION	DATE	01	REVISION A	09.16.14	02	REVISION B	09.16.14	03	REVISION C	10.29.14	04	AV 100% DD FINAL REVISION	11.24.15	05	100% CD FOR CONSTRUCTION	03.25.16	DRAWN: TL PREPARED: RST TRACED: TL APPROVED: RST CHECKED: TL APPROVED: RST		DEMONICA KEMPER ARCHITECTS 125 N. HALSTED STREET, SUITE 301 CHICAGO, IL 60661 P: 312.496.0000	KJWW ENGINEERING 1100 WARRENVILLE ROAD, #400W NAPERVILLE, IL 60563 T: 312.559.4585	E.F. WHITNEY, INC. 568 ANN STREET BIRMINGHAM, MI 48009 T: 248.644.0990	SHEN MILSON WILKE 2 N. RIVERSIDE PLAZA CHICAGO, IL 60606 T: 312.559.4585	100% CD FOR CONSTRUCTION AUDIOVISUAL RCP LEVEL 06	PROJECT NO. DATE: APRIL 21, 2016 SHEET NO. TA206
NO.	DESCRIPTION	DATE																										
01	REVISION A	09.16.14																										
02	REVISION B	09.16.14																										
03	REVISION C	10.29.14																										
04	AV 100% DD FINAL REVISION	11.24.15																										
05	100% CD FOR CONSTRUCTION	03.25.16																										
CITY CENTER CAMPUS JOLIET JUNIOR COLLEGE																												

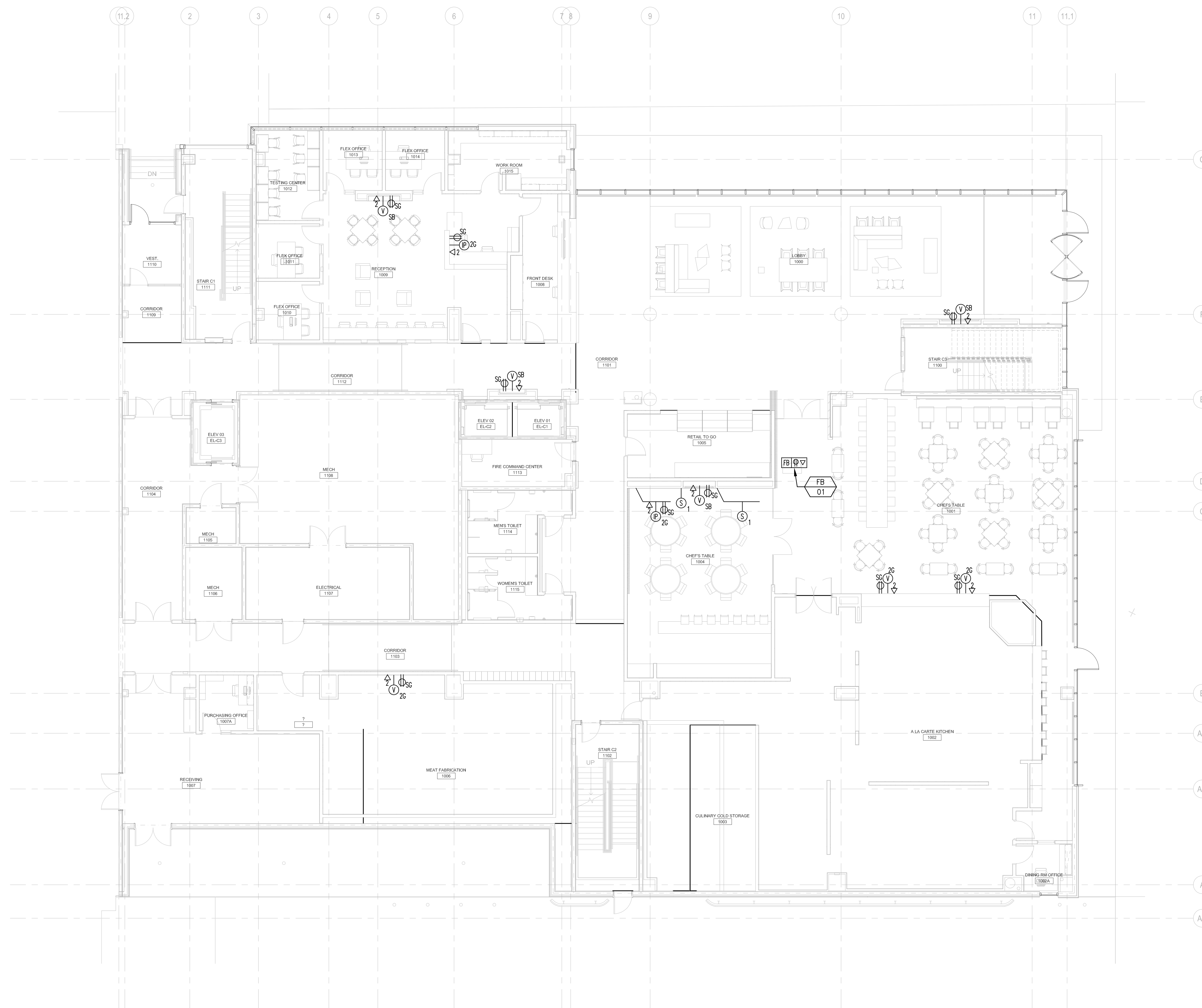

1 AUDIOVISUAL LEVEL 01 INFRASTRUCTURE - FLOOR PLAN
1/8" = 1'-0"

NOTE: CONTRACTOR SHALL VERIFY ALL DIMENSIONS AND CONDITIONS AT JOB SITE AND BE FULLY RESPONSIBLE FOR SAME.

REVISIONS		
NO.	DESCRIPTION	DATE
01	REVISION A	09.16.14
02	REVISION B	09.16.14
03	REVISION C	10.29.14
04	AV 100% DD FINAL REVISION	11.24.15
05	100% CD FOR CONSTRUCTION	03.25.16

DRAWN	PREPARED
TL	RST
TRACED	APPROVED
TL	RST
CHECKED	APPROVED
TL	RST

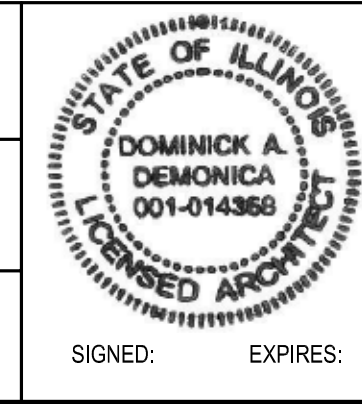

DKA DEMONICA KEMPER ARCHITECTS
125 N. HALSTED STREET, SUITE 301
CHICAGO, IL 60661
P: 312.496.0000

KJW KJWW ENGINEERING
1100 WARRENVILLE ROAD, #400W
NAPERVILLE, IL 60563
T: 312.559.4585

EFW E.F. WHITNEY, INC.
568 ANN STREET
BIRMINGHAM, MI 48009
T: 248.644.0990

SM&W SHEN MILSOM WILKE
2 N. RIVERSIDE PLAZA
CHICAGO, IL 60606
T: 312.559.4585

100% CD FOR CONSTRUCTION		PROJECT NO.
AUDIOVISUAL LEVEL 01 INFRASTRUCTURE		DATE APRIL 21, 2016
CITY CENTER CAMPUS JOLIET JUNIOR COLLEGE		SHEET NO. TA301

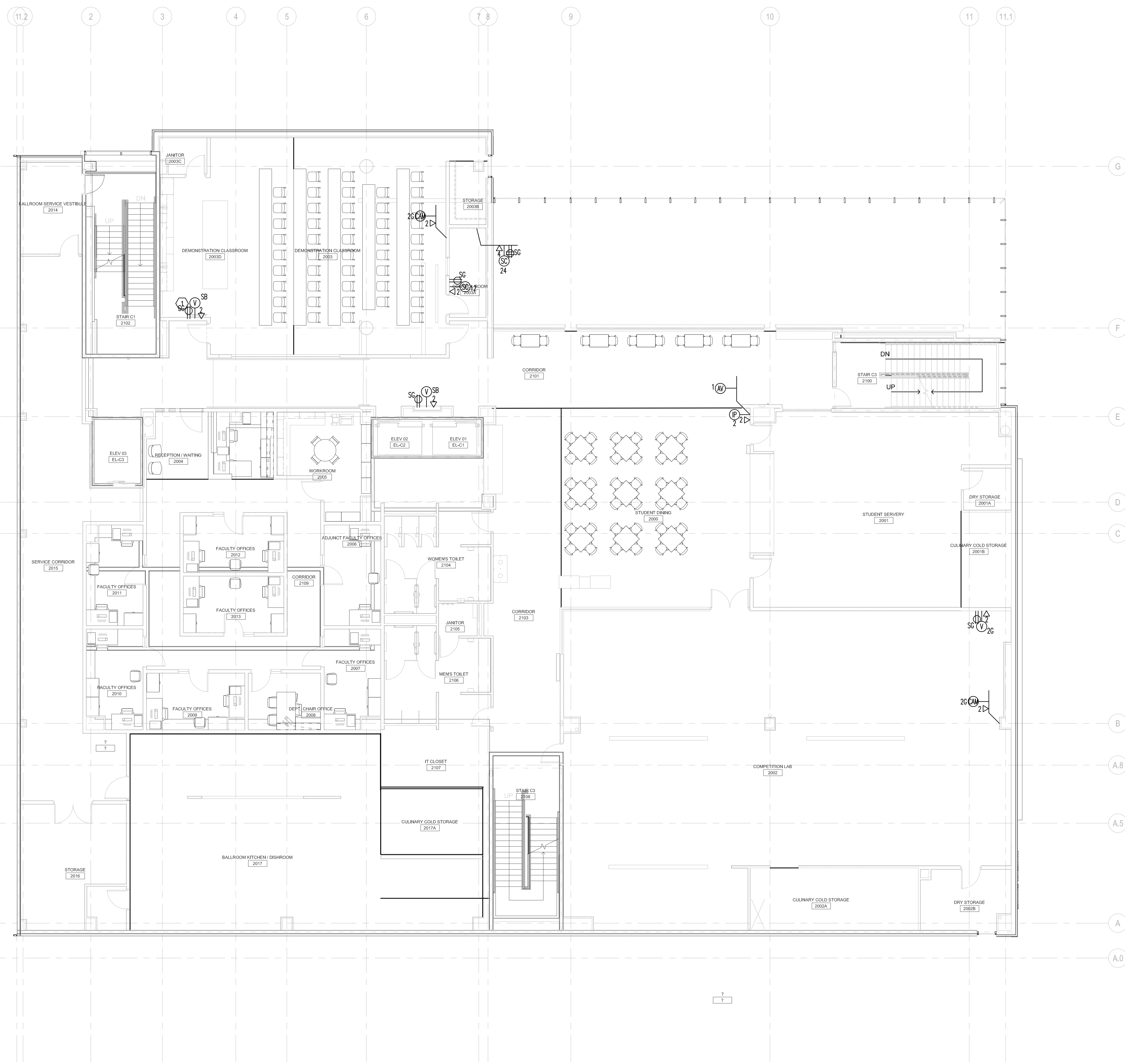

SHEET NOTES: ①
 1. AV, DATA AND AC POWER LOCATED AT THREE LOCATIONS FOR STACKED FLAT PANEL DISPLAYS

1 AUDIOVISUAL LEVEL 02 INFRASTRUCTURE - FLOOR PLAN
 1/8" = 1'-0"

NOTE: CONTRACTOR SHALL VERIFY ALL DIMENSIONS AND CONDITIONS AT JOB SITE AND BE FULLY RESPONSIBLE FOR SAME.

REVISIONS		
NO.	DESCRIPTION	DATE
01	REVISION A	09.16.14
02	REVISION B	09.16.14
03	REVISION C	10.29.14
04	AV 100% DD FINAL REVISION	11.24.15
05	100% CD FOR CONSTRUCTION	03.25.16

DRAWN	PREPARED
TL	RST
TRACED	APPROVED
TL	RST
CHECKED	APPROVED
TL	RST

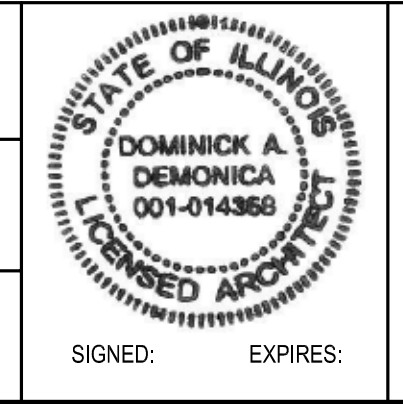

dkA DEMONICK KEMPER ARCHITECTS
 125 N. HALSTED STREET, SUITE 301
 CHICAGO, IL 60661
 P: 312.496.0000

KJW KJWW ENGINEERING
 1100 WARRENVILLE ROAD, #400W
 NAPERVILLE, IL 60563
 T: 312.559.4585

EFW E.F. WHITNEY, INC.
 568 ANN STREET
 BIRMINGHAM, MI 48009
 T: 248.644.0990

SM&W SHEN MILSOM WILKE
 2 N. RIVERSIDE PLAZA
 CHICAGO, IL 60606
 T: 312.559.4585

100% CD FOR CONSTRUCTION		PROJECT NO.
AUDIOVISUAL LEVEL 02 INFRASTRUCTURE		DATE APRIL 21, 2016
CITY CENTER CAMPUS JOLIET JUNIOR COLLEGE		SHEET NO. TA302

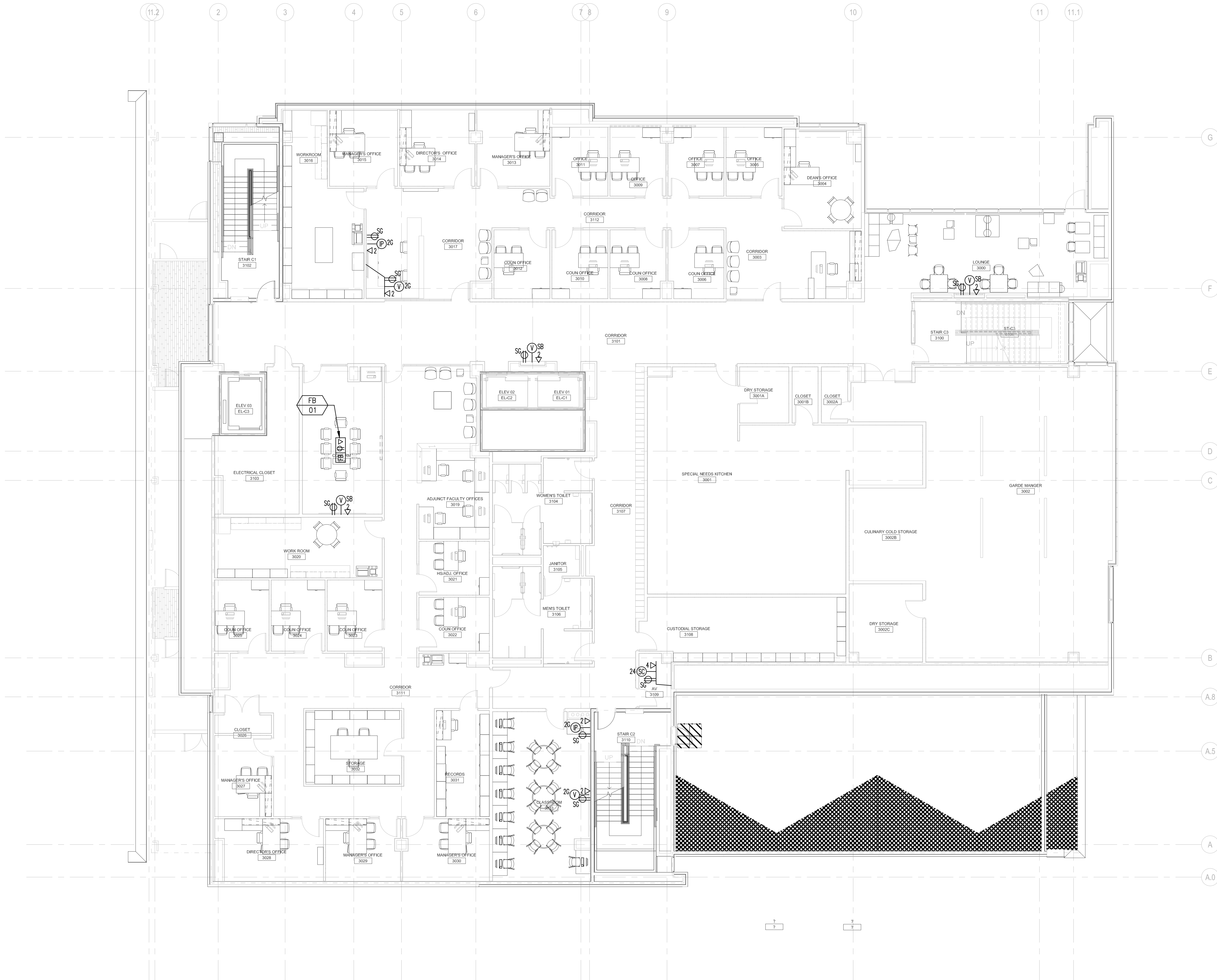

1 AUDIOVISUAL LEVEL 03 INFRASTRUCTURE - FLOOR PLAN
1/8" = 1'-0"

NOTE: CONTRACTOR SHALL VERIFY ALL DIMENSIONS AND CONDITIONS AT JOB SITE AND BE FULLY RESPONSIBLE FOR SAME.

REVISIONS		
NO.	DESCRIPTION	DATE
01	REVISION A	09.16.14
02	REVISION B	09.16.14
03	REVISION C	10.29.14
04	AV 100% DD FINAL REVISION	11.24.15
05	100% CD FOR CONSTRUCTION	03.25.16

DRAWN	PREPARED
TL	RST
TRACED	APPROVED
TL	RST
CHECKED	APPROVED
TL	RST

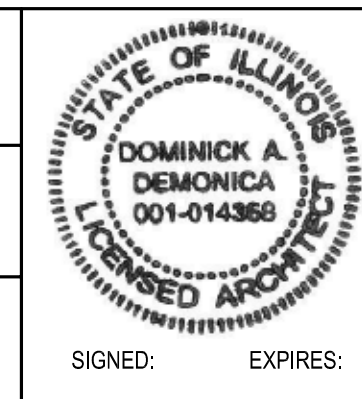

dkA DEMONICA KEMPER ARCHITECTS
125 N. HALSTED STREET, SUITE 301
CHICAGO, IL 60661
P: 312.496.0000

KJWW KJWW ENGINEERING
1100 WARRENVILLE ROAD, #400W
NAPERVILLE, IL 60563
T: 312.559.4585

EFW E.F. WHITNEY, INC.
568 ANN STREET
BIRMINGHAM, MI 48009
T: 248.644.0990

SM&W SHEN MILSOM WILKE LLC
2 N. RIVERSIDE PLAZA
CHICAGO, IL 60606
T: 312.559.4585

100% CD FOR CONSTRUCTION		PROJECT NO.
AUDIOVISUAL LEVEL 03 INFRASTRUCTURE		DATE APRIL 21, 2016
CITY CENTER CAMPUS JOLIET JUNIOR COLLEGE		SHEET NO. TA303

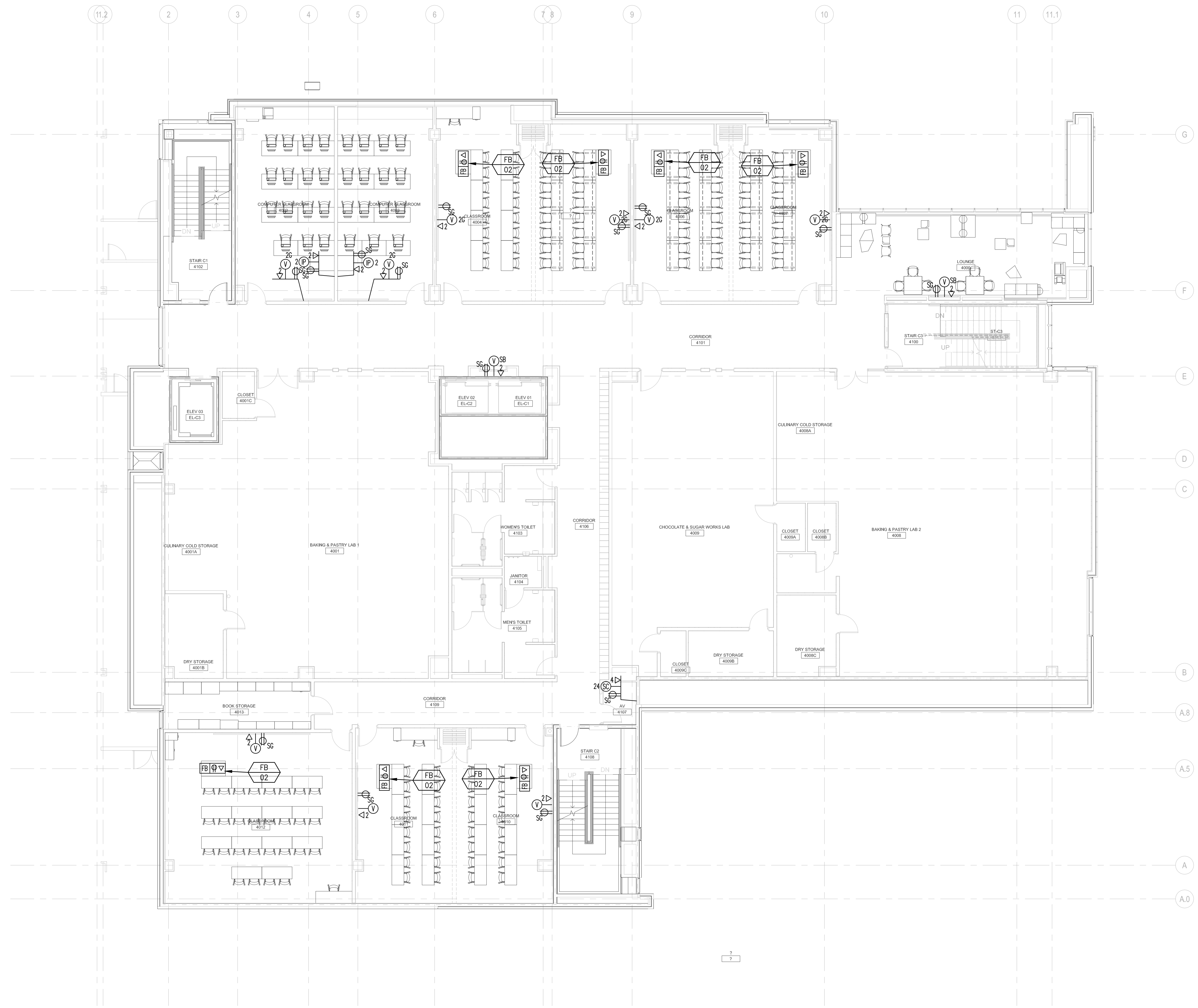

1 AUDIOVISUAL LEVEL 04 INFRASTRUCTURE - FLOOR PLAN
 1/8" = 1'-0"

NOTE: CONTRACTOR SHALL VERIFY ALL DIMENSIONS AND CONDITIONS AT JOB SITE AND BE FULLY RESPONSIBLE FOR SAME.

REVISIONS		
NO.	DESCRIPTION	DATE
01	REVISION A	09.16.14
02	REVISION B	09.16.14
03	REVISION C	10.29.14
04	AV 100% DD FINAL REVISION	11.24.15
05	100% CD FOR CONSTRUCTION	03.25.16

DRAWN	PREPARED
TL	RST
TRACED	APPROVED
TL	RST
CHECKED	APPROVED
TL	RST

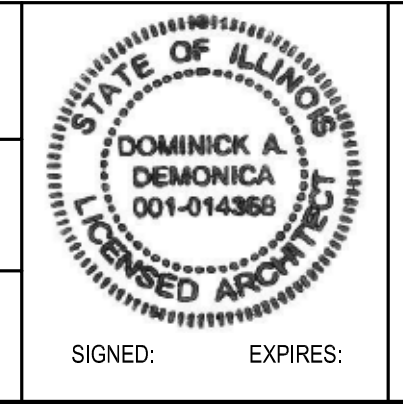

dkA DEMONICA KEMPER ARCHITECTS
 125 N. HALSTED STREET, SUITE 301
 CHICAGO, IL 60661
 P: 312.496.0000

KJW KJWW ENGINEERING
 1100 WARRENVILLE ROAD, #400W
 NAPERVILLE, IL 60563
 T: 312.559.4585

EFW E.F. WHITNEY, INC.
 568 ANN STREET
 BIRMINGHAM, MI 48009
 T: 248.644.0990

SM&W SHEN MILSON WILKE
 2 N. RIVERSIDE PLAZA
 CHICAGO, IL 60606
 T: 312.559.4585

100% CD FOR CONSTRUCTION		PROJECT NO.
AUDIOVISUAL LEVEL 04 INFRASTRUCTURE		DATE
CITY CENTER CAMPUS JOLIET JUNIOR COLLEGE		SHEET NO.
		TA304

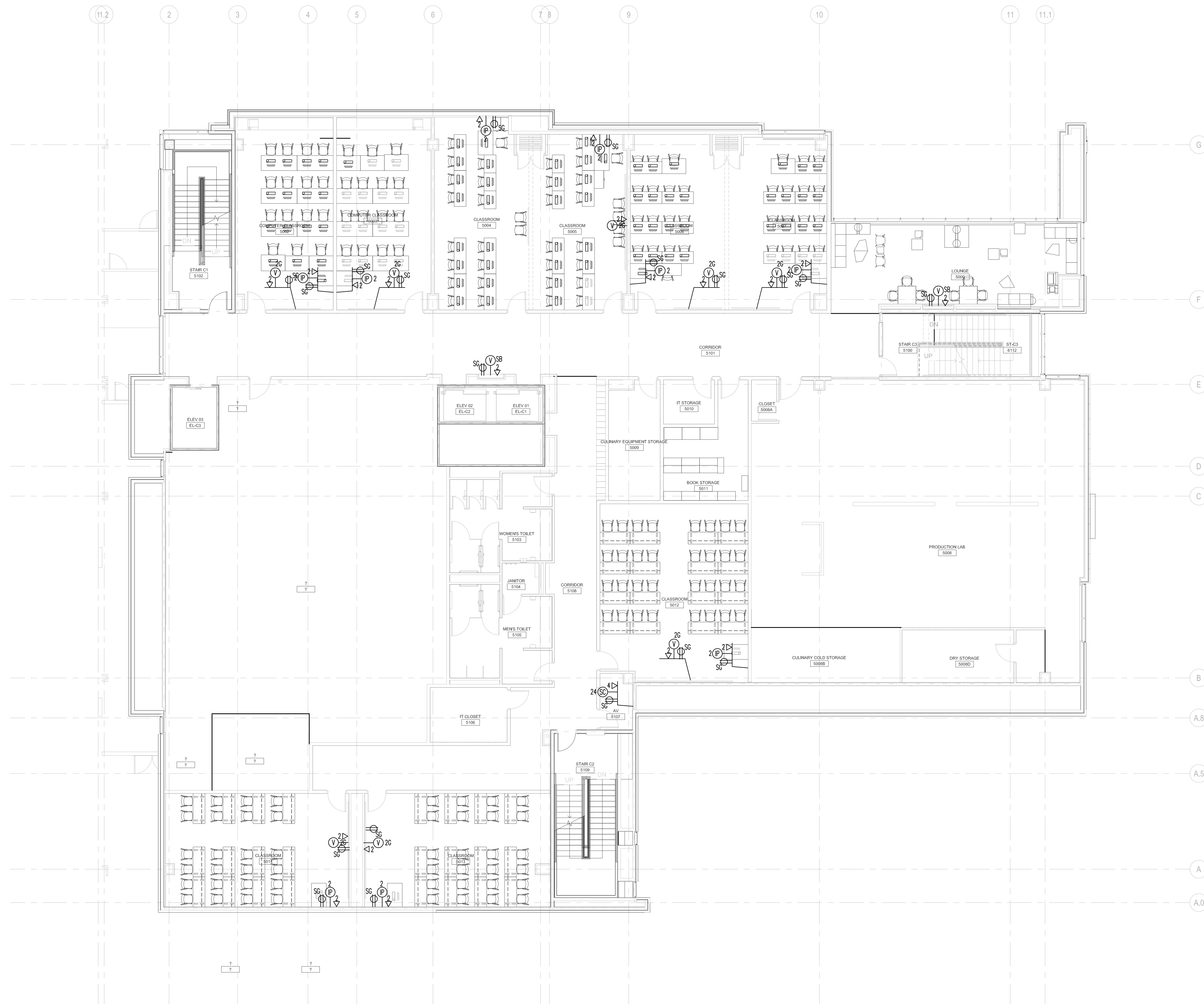

1 AUDIOVISUAL LEVEL 05 INFRASTRUCTURE - FLOOR PLAN
1/8" = 1'-0"

NOTE: CONTRACTOR SHALL VERIFY ALL DIMENSIONS AND CONDITIONS AT JOB SITE AND BE FULLY RESPONSIBLE FOR SAME.

REVISIONS			DRAWN	PREPARED	100% CD FOR CONSTRUCTION				PROJECT NO.	
NO.	DESCRIPTION	DATE	TL	RST	AUDIOVISUAL LEVEL 05 INFRASTRUCTURE					
01	REVISION A	09.16.14	TRACED	APPROVED	<div style="display: flex; justify-content: space-between;"> <div style="text-align: center;"> <p>DOMINICK A. DEMONICK 001-014360 REGISTERED ARCHITECT</p> </div> <div style="text-align: center;"> <p>DEMOMONICK KEMPER ARCHITECTS 125 N. HALSTED STREET, SUITE 301 CHICAGO, IL 60661 P: 312.496.0000</p> </div> <div style="text-align: center;"> <p>KJWW ENGINEERING 1100 WARRENVILLE ROAD, #400W NAPERVILLE, IL 60563 T: 312.559.4585</p> </div> <div style="text-align: center;"> <p>E.F. WHITNEY, INC. 568 ANN STREET BIRMINGHAM, MI 48009 T: 248.644.0990</p> </div> <div style="text-align: center;"> <p>SHEN MILSON WILKE 2 N. RIVERSIDE PLAZA CHICAGO, IL 60606 T: 312.559.4585</p> </div> </div>				TA305	
02	REVISION B	09.16.14	TL	RST					DATE	APRIL 21, 2016
03	REVISION C	10.29.14	TL	RST					SHEET NO.	
04	AV 100% DD FINAL REVISION	11.24.15	CHECKED	APPROVED						
05	100% CD FOR CONSTRUCTION	03.25.16	TL	RST						

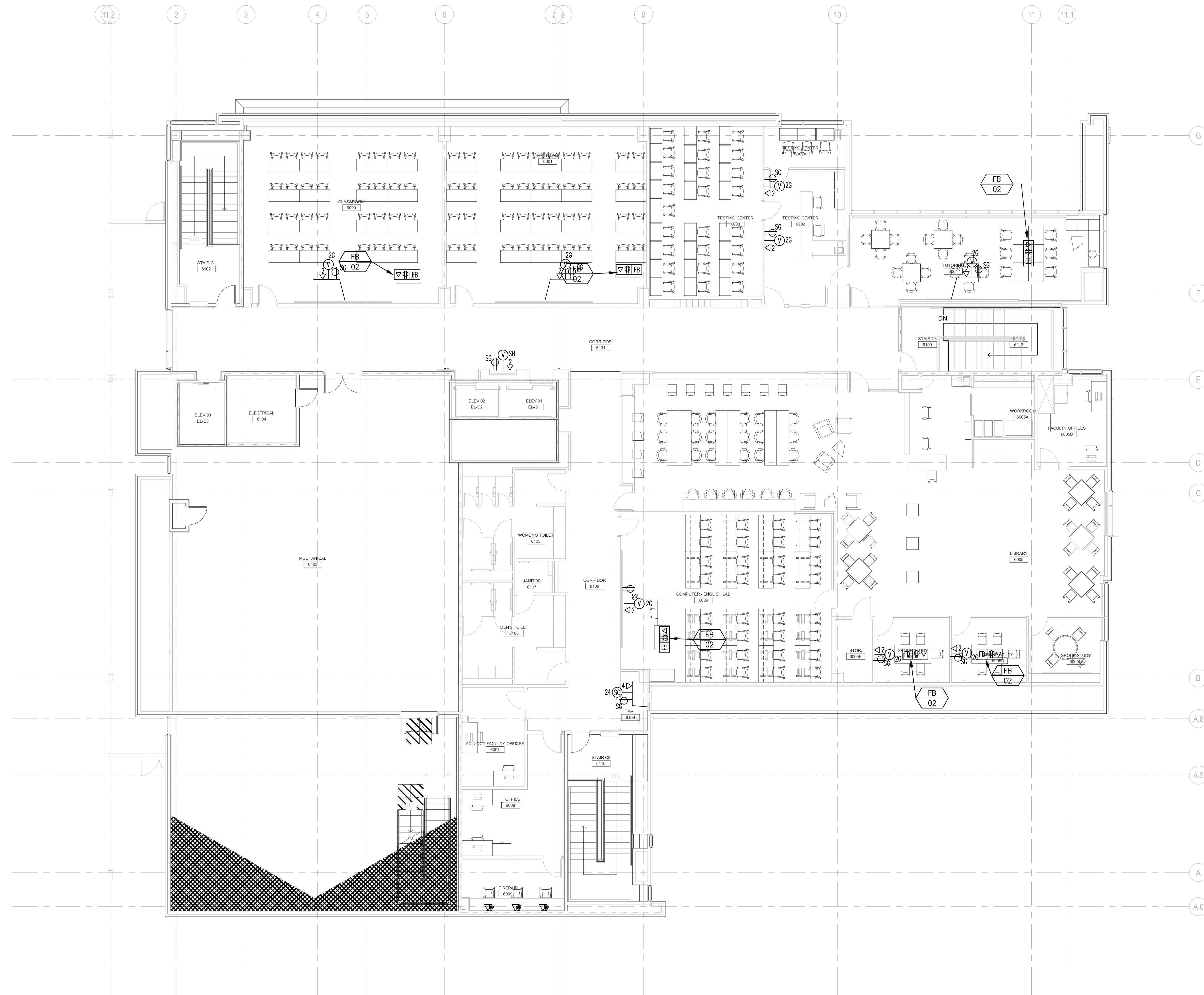

1 AUDIOVISUAL LEVEL 06 INFRASTRUCTURE - FLOOR PLAN
1/8" = 1'-0"

NOTE: CONTRACTOR SHALL VERIFY ALL DIMENSIONS AND CONDITIONS AT JOB SITE AND BE FULLY RESPONSIBLE FOR SAME.

REVISIONS		
NO.	DESCRIPTION	DATE
01	REVISION A	09.16.14
02	REVISION B	09.16.14
03	REVISION C	10.29.14
04	AV 100% DD FINAL REVISION	11.24.15
05	100% CD FOR CONSTRUCTION	03.25.16

DRAWN	PREPARED
TL	RST
TRACED	APPROVED
TL	RST
CHECKED	APPROVED
TL	RST

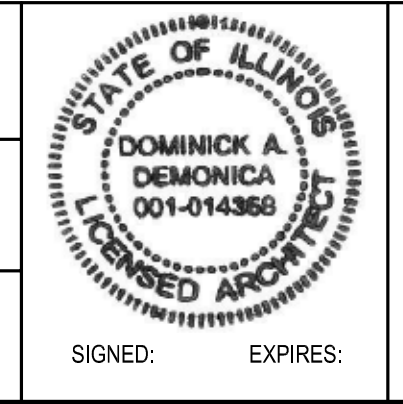

dka DEMONICK KEMPER ARCHITECTS
125 N. HALSTED STREET, SUITE 301
CHICAGO, IL 60661
P: 312.496.0000

KJW KJWW ENGINEERING
1100 WARRENVILLE ROAD, #400W
NAPERVILLE, IL 60563
T: 312.559.4585

EFW E.F. WHITNEY, INC.
568 ANN STREET
BIRMINGHAM, MI 48009
T: 248.644.0990

SM&W SHEN MILSON WILKE
2 N. RIVERSIDE PLAZA
CHICAGO, IL 60606
T: 312.559.4585

100% CD FOR CONSTRUCTION		PROJECT NO.
AUDIOVISUAL LEVEL 06 INFRASTRUCTURE		DATE
CITY CENTER CAMPUS JOLIET JUNIOR COLLEGE		APRIL 21, 2016
		SHEET NO.
		TA306

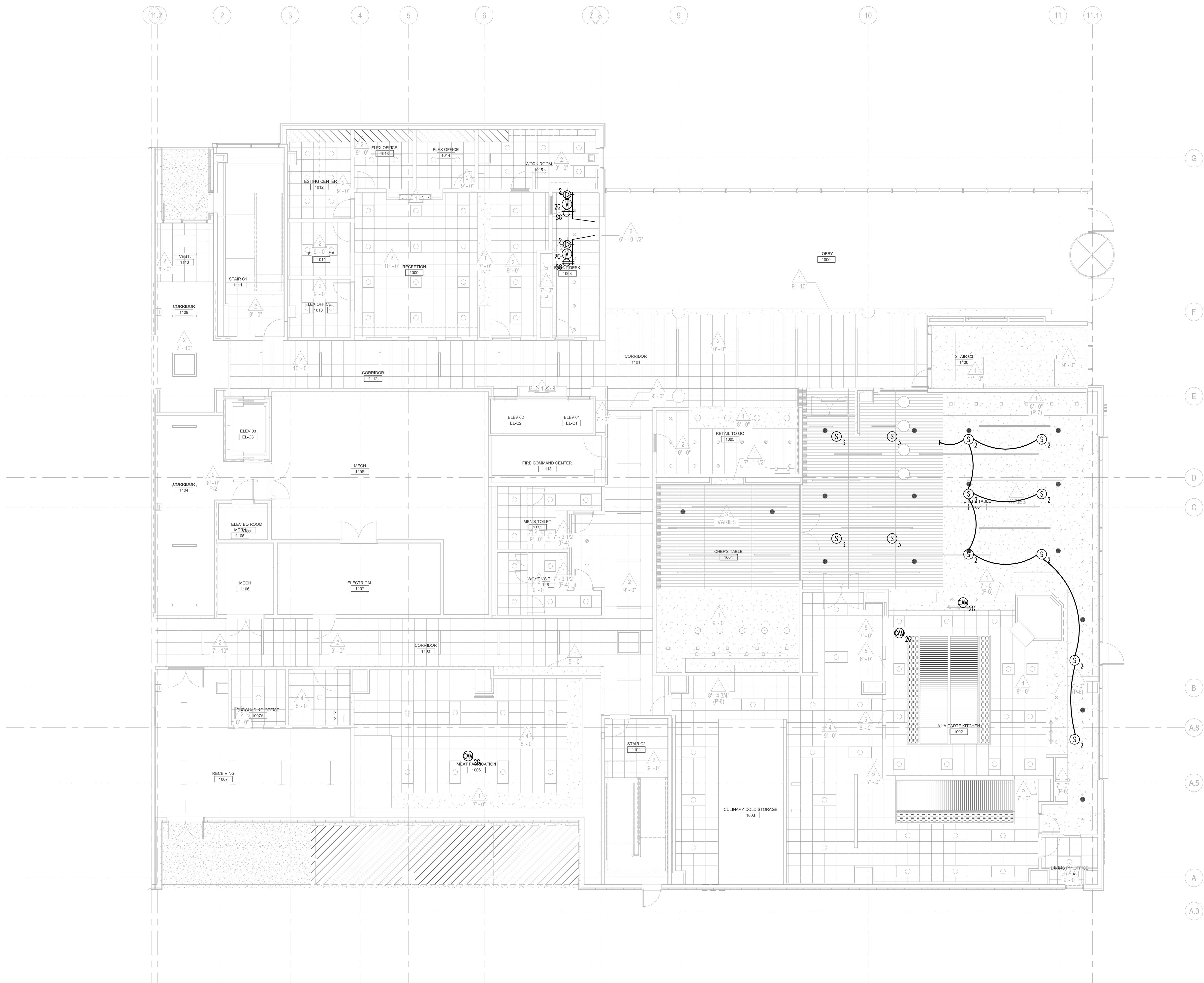

1 AUDIOVISUAL LEVEL 01 INFRASTRUCTURE - RCP
1/8" = 1'-0"

NOTE: CONTRACTOR SHALL VERIFY ALL DIMENSIONS AND CONDITIONS AT JOB SITE AND BE FULLY RESPONSIBLE FOR SAME.

REVISIONS			DRAWN	PREPARED					100% CD FOR CONSTRUCTION		PROJECT NO.
NO.	DESCRIPTION	DATE	TL	RST					AUDIOVISUAL RCP LEVEL 01 INFRASTRUCTURE		DATE
01	REVISION A	09.16.14	TL	RST							APRIL 21, 2016
02	REVISION B	09.16.14	TRACED	APPROVED							SHEET NO.
03	REVISION C	10.29.14	TL	RST							TA401
04	AV 100% DD FINAL REVISION	11.24.15	CHECKED	APPROVED							
05	100% CD FOR CONSTRUCTION	03.25.16	TL	RST							



dka DEMONICK KEMPER ARCHITECTS
125 N. HALSTED STREET, SUITE 301
CHICAGO, IL 60661
P: 312.496.0000

KJW KJWW ENGINEERING
1100 WARRENVILLE ROAD, #400W
NAPERVILLE, IL 60563
T: 312.559.4585

EFW E.F. WHITNEY, INC.
568 ANN STREET
BIRMINGHAM, MI 48009
T: 248.644.0990

SMR&W SHEN MILSOM WILKE LLC
2 N. RIVERSIDE PLAZA
CHICAGO, IL 60606
T: 312.559.4585

100% CD FOR CONSTRUCTION		PROJECT NO.
AUDIOVISUAL RCP LEVEL 01 INFRASTRUCTURE		DATE
CITY CENTER CAMPUS JOLIET JUNIOR COLLEGE		SHEET NO.
		TA401

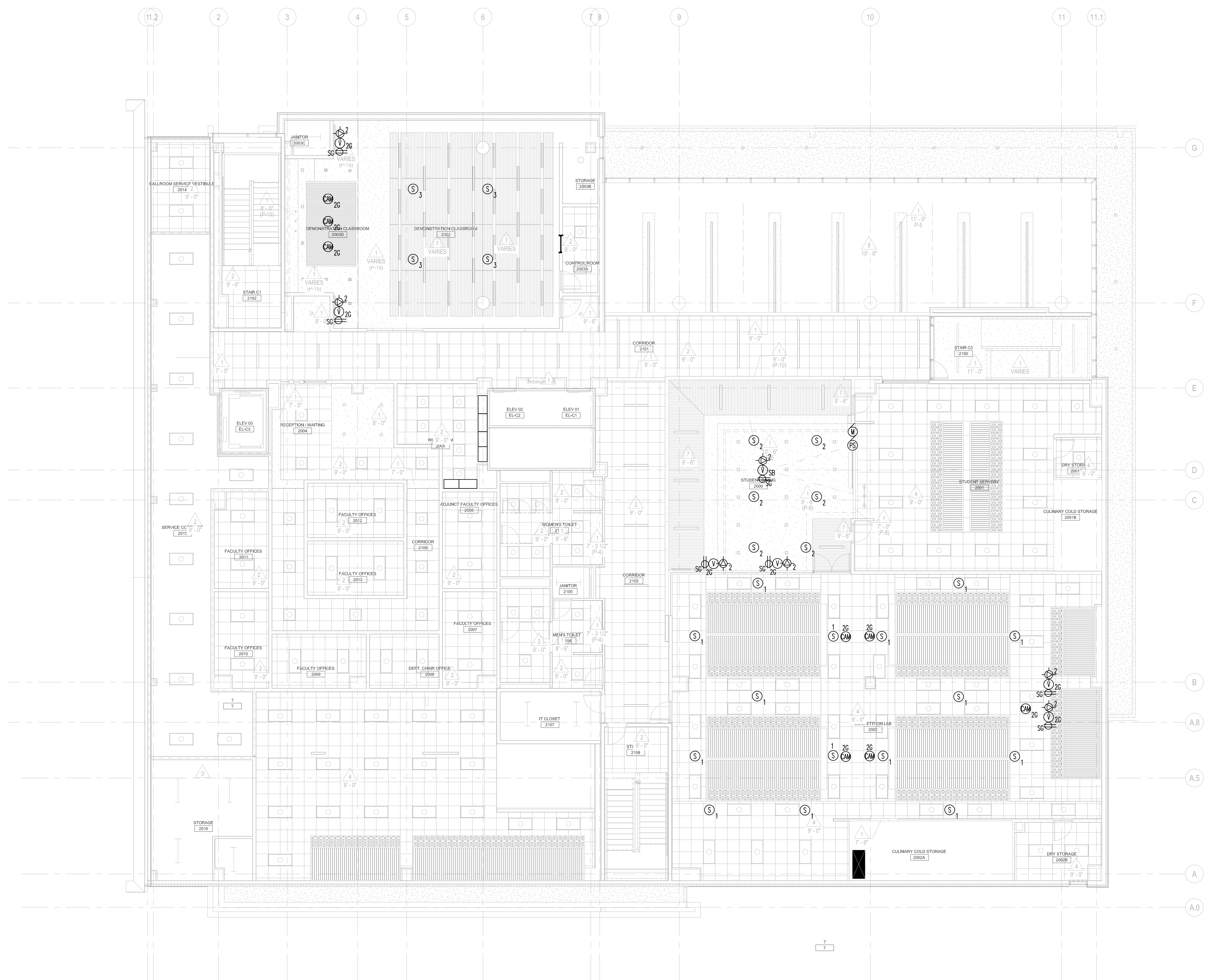

1 AUDIOVISUAL LEVEL 02 INFRASTRUCTURE - RCP
 1/8" = 1'-0"

NOTE: CONTRACTOR SHALL VERIFY ALL DIMENSIONS AND CONDITIONS AT JOB SITE AND BE FULLY RESPONSIBLE FOR SAME.

REVISIONS		
NO.	DESCRIPTION	DATE
01	REVISION A	09.16.14
02	REVISION B	09.16.14
03	REVISION C	10.29.14
04	AV 100% DD FINAL REVISION	11.24.15
05	100% CD FOR CONSTRUCTION	03.25.16

DRAWN	PREPARED
TL	RST
TRACED	APPROVED
TL	RST
CHECKED	APPROVED
TL	RST

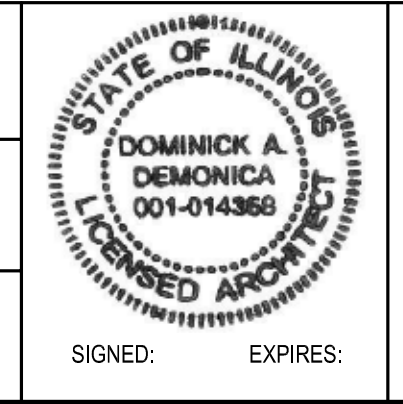

DKA DEMONICA
 KEMPER
 ARCHITECTS
 125 N. HALSTED STREET,
 SUITE 301
 CHICAGO, IL 60661
 P: 312.496.0000

KJW KJWW
 ENGINEERING
 1100 WARRENVILLE
 ROAD, #400W
 NAPERVILLE, IL 60563
 T: 312.559.4585

EFW E.F. WHITNEY,
 INC.
 568 ANN STREET
 BIRMINGHAM, MI 48009
 T: 248.644.0990



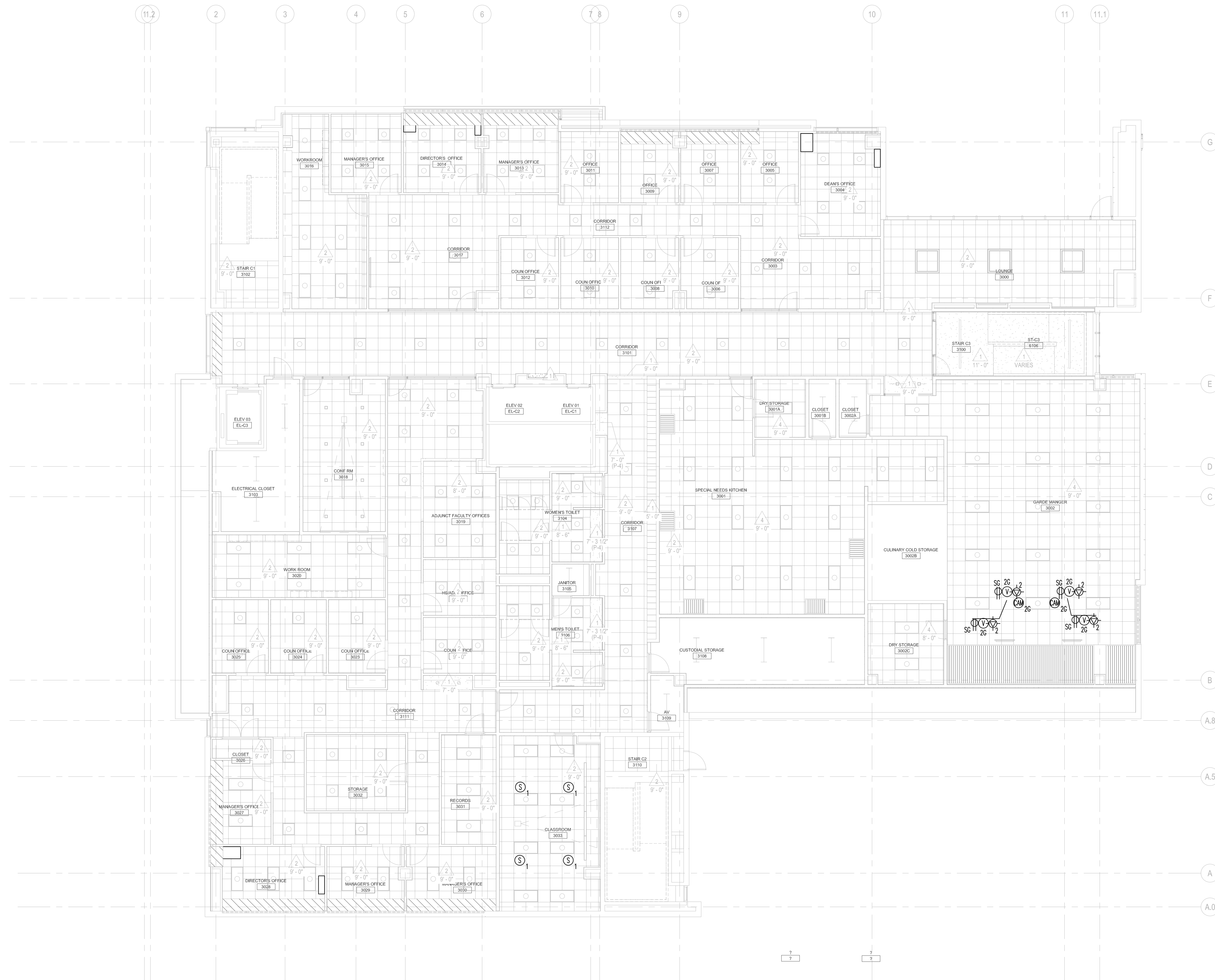

SM&W SHEN MILSOM
 WILKE LLC
 SHEN MILSOM WILKE
 2 N. RIVERSIDE PLAZA
 CHICAGO, IL 60606
 T: 312.559.4585

100% CD FOR CONSTRUCTION		PROJECT NO.
AUDIOVISUAL RCP LEVEL 02 INFRASTRUCTURE		DATE APRIL 21, 2016
CITY CENTER CAMPUS JOLIET JUNIOR COLLEGE		SHEET NO. TA402



1 AUDIOVISUAL LEVEL 03 INFRASTRUCTURE - RCP
1/8" = 1'-0"

NOTE: CONTRACTOR SHALL VERIFY ALL DIMENSIONS AND CONDITIONS AT JOB SITE AND BE FULLY RESPONSIBLE FOR SAME.

REVISIONS			DRAWN	PREPARED	100% CD FOR CONSTRUCTION				PROJECT NO.						
NO.	DESCRIPTION	DATE	TL	RST	AUDIOVISUAL RCP LEVEL 03 INFRASTRUCTURE				PROJECT NO.						
01	REVISION A	09.16.14	TRACED	APPROVED	<div style="display: flex; justify-content: space-between; align-items: center;"> <div style="text-align: center;">  <p>DKA DEMONICA KEMPER ARCHITECTS</p> <p>125 N. HALSTED STREET, SUITE 301 CHICAGO, IL 60661 P: 312.496.0000</p> </div> <div style="text-align: center;">  <p>KJW KJWW ENGINEERING</p> <p>1100 WARRENVILLE ROAD, #400W NAPERVILLE, IL 60563 T: 312.559.4585</p> </div> <div style="text-align: center;">  <p>EFW E.F. WHITNEY, INC.</p> <p>568 ANN STREET BIRMINGHAM, MI 48009 T: 248.644.0990</p> </div> <div style="text-align: center;">  <p>SM&W SHEN MILSOM WILKE LLC</p> <p>2 N. RIVERSIDE PLAZA CHICAGO, IL 60606 T: 312.559.4585</p> </div> </div>				PROJECT NO.						
02	REVISION B	09.16.14	TL	RST					DATE	APRIL 21, 2016	SHEET NO.	TA403			
03	REVISION C	10.29.14	TL	RST					<div style="text-align: center;"> <p>CITY CENTER CAMPUS JOLIET JUNIOR COLLEGE</p> </div>						
04	AV 100% DD FINAL REVISION	11.24.15	CHECKED	APPROVED											
05	100% CD FOR CONSTRUCTION	03.25.16	TL	RST											

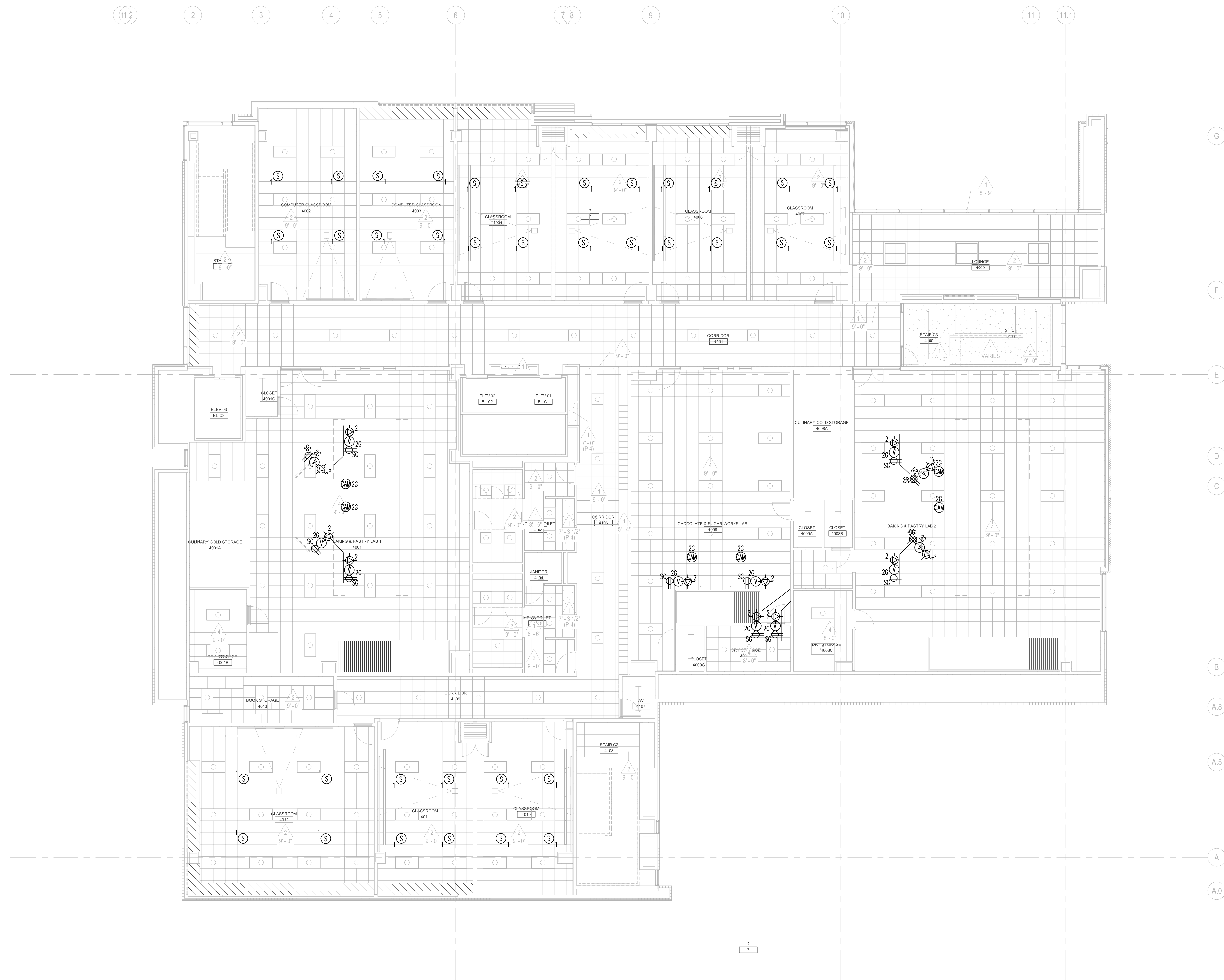

1 AUDIOVISUAL LEVEL 04 INFRASTRUCTURE - RCP
1/8" = 1'-0"

NOTE: CONTRACTOR SHALL VERIFY ALL DIMENSIONS AND CONDITIONS AT JOB SITE AND BE FULLY RESPONSIBLE FOR SAME.

REVISIONS		
NO.	DESCRIPTION	DATE
01	REVISION A	09.16.14
02	REVISION B	09.16.14
03	REVISION C	10.29.14
04	AV 100% DD FINAL REVISION	11.24.15
05	100% CD FOR CONSTRUCTION	03.25.16

DRAWN	PREPARED
TL	RST
TRACED	APPROVED
TL	RST
CHECKED	APPROVED
TL	RST

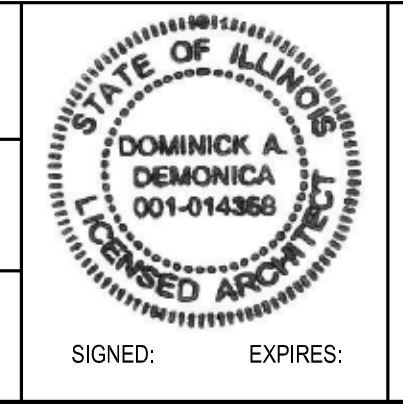

dka DEMONICA KEMPER ARCHITECTS
125 N. HALSTED STREET, SUITE 301
CHICAGO, IL 60661
P: 312.496.0000

KJW KJWW ENGINEERING
1100 WARRENVILLE ROAD, #400W
NAPERVILLE, IL 60563
T: 312.559.4585

EFW E.F. WHITNEY, INC.
568 ANN STREET
BIRMINGHAM, MI 48009
T: 248.644.0990

SM&W SHEN MILSON WILKE
2 N. RIVERSIDE PLAZA
CHICAGO, IL 60606
T: 312.559.4585

100% CD FOR CONSTRUCTION		PROJECT NO.
AUDIOVISUAL RCP LEVEL 04 INFRASTRUCTURE		DATE APRIL 21, 2016
CITY CENTER CAMPUS JOLIET JUNIOR COLLEGE		SHEET NO. TA404

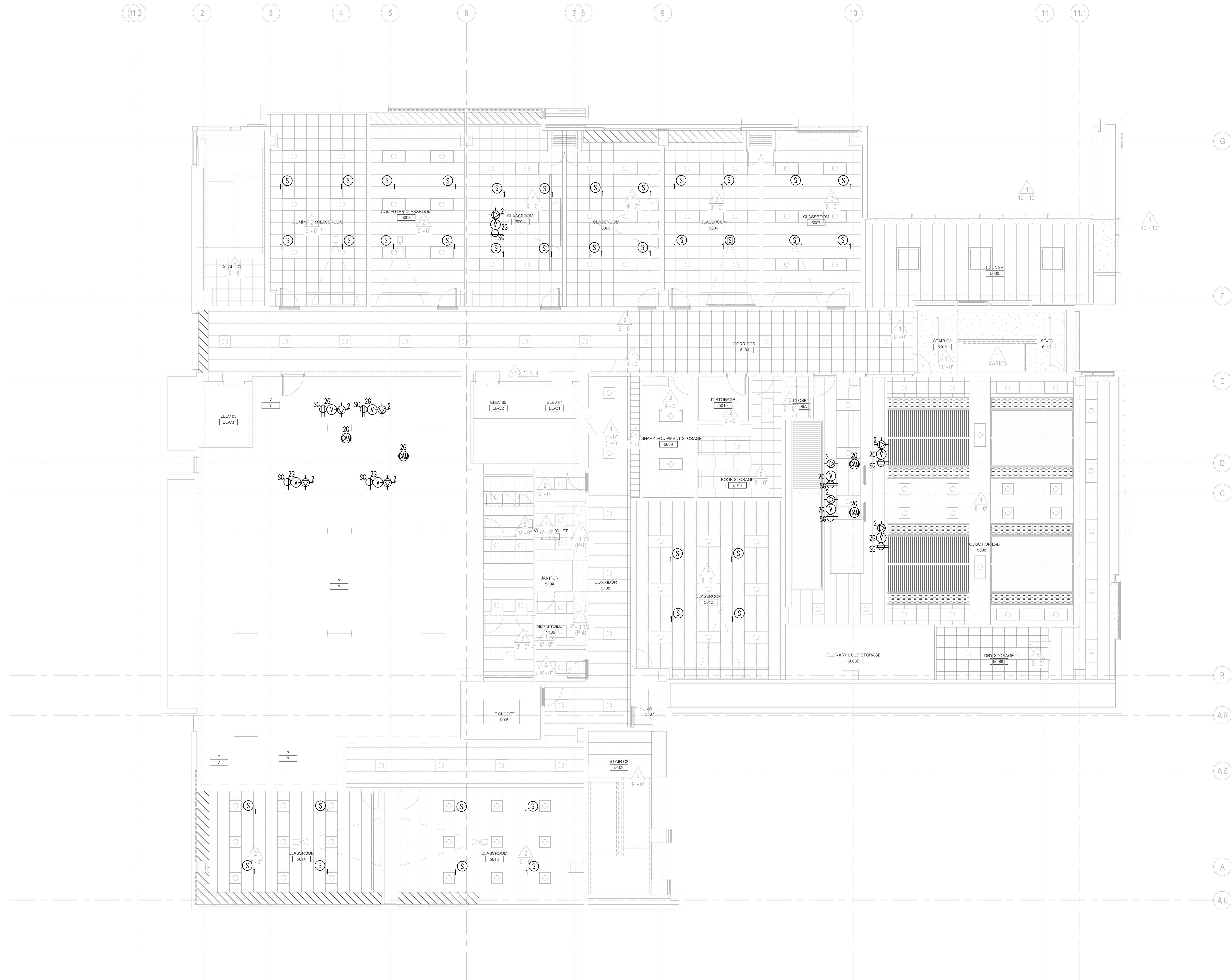

1 AUDIOVISUAL LEVEL 05 INFRASTRUCTURE - RCP
 1/8" = 1'-0"

NOTE: CONTRACTOR SHALL VERIFY ALL DIMENSIONS AND CONDITIONS AT JOB SITE AND BE FULLY RESPONSIBLE FOR SAME.

REVISIONS			DRAWN	PREPARED	100% CD FOR CONSTRUCTION				AUDIOVISUAL RCP LEVEL 05 INFRASTRUCTURE		PROJECT NO.
NO.	DESCRIPTION	DATE	TL	RST					CITY CENTER CAMPUS JOLIET JUNIOR COLLEGE		DATE
01	REVISION A	09.16.14	TL	RST							APRIL 21, 2016
02	REVISION B	09.16.14	TL	RST							SHEET NO.
03	REVISION C	10.29.14	TL	RST							TA405
04	AV 100% DD FINAL REVISION	11.24.15	TL	RST							
05	100% CD FOR CONSTRUCTION	03.25.16	TL	RST							

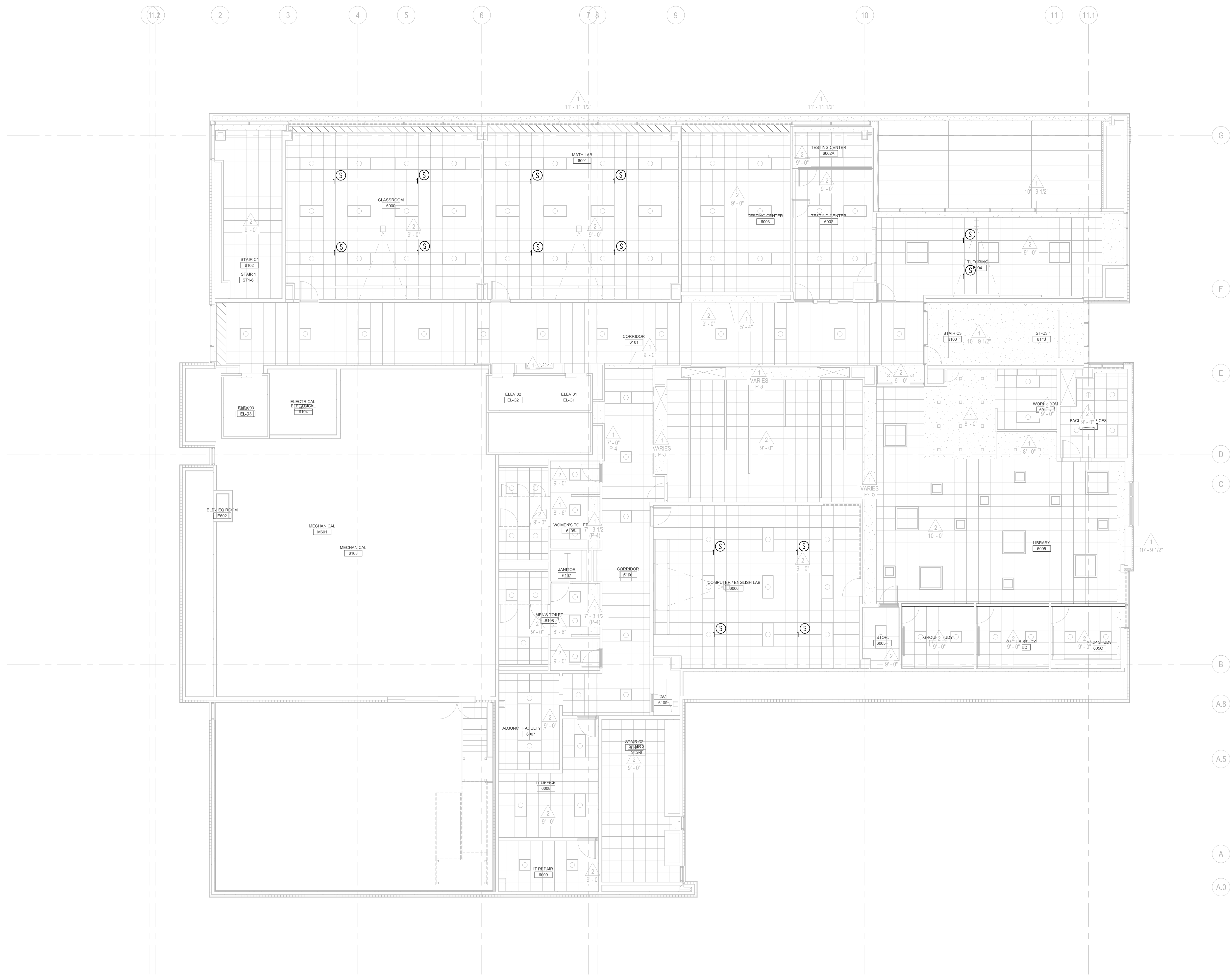

1 AUDIOVISUAL LEVEL 06 INFRASTRUCTURE - RCP
1/8" = 1'-0"

NOTE: CONTRACTOR SHALL VERIFY ALL DIMENSIONS AND CONDITIONS AT JOB SITE AND BE FULLY RESPONSIBLE FOR SAME.

REVISIONS		
NO.	DESCRIPTION	DATE
01	REVISION A	09.16.14
02	REVISION B	09.16.14
03	REVISION C	10.29.14
04	AV 100% DD FINAL REVISION	11.24.15
05	100% CD FOR CONSTRUCTION	03.25.16

DRAWN	PREPARED
TL	RST
TRACED	APPROVED
TL	RST
CHECKED	APPROVED
TL	RST

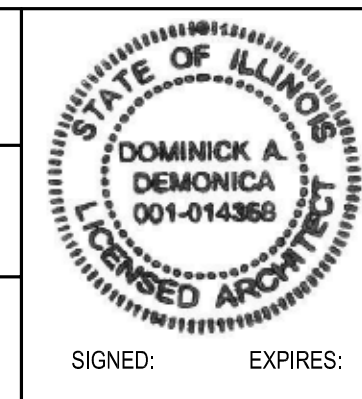

dkA DEMONICK A. DEMONICA ARCHITECTS
125 N. HALSTED STREET, SUITE 301
CHICAGO, IL 60661
P: 312.496.0000

KJWW KJWW ENGINEERING
1100 WARRENVILLE ROAD, #400W
NAPERVILLE, IL 60563
T: 312.559.4585

EFW E.F. WHITNEY, INC.
568 ANN STREET
BIRMINGHAM, MI 48009
T: 248.644.0990

SM&W SHEN MILSON WILKE
2 N. RIVERSIDE PLAZA
CHICAGO, IL 60606
T: 312.559.4585

100% CD FOR CONSTRUCTION		PROJECT NO.
AUDIOVISUAL RCP LEVEL 06 INFRASTRUCTURE		DATE APRIL 21, 2016
CITY CENTER CAMPUS JOLIET JUNIOR COLLEGE		SHEET NO. TA406

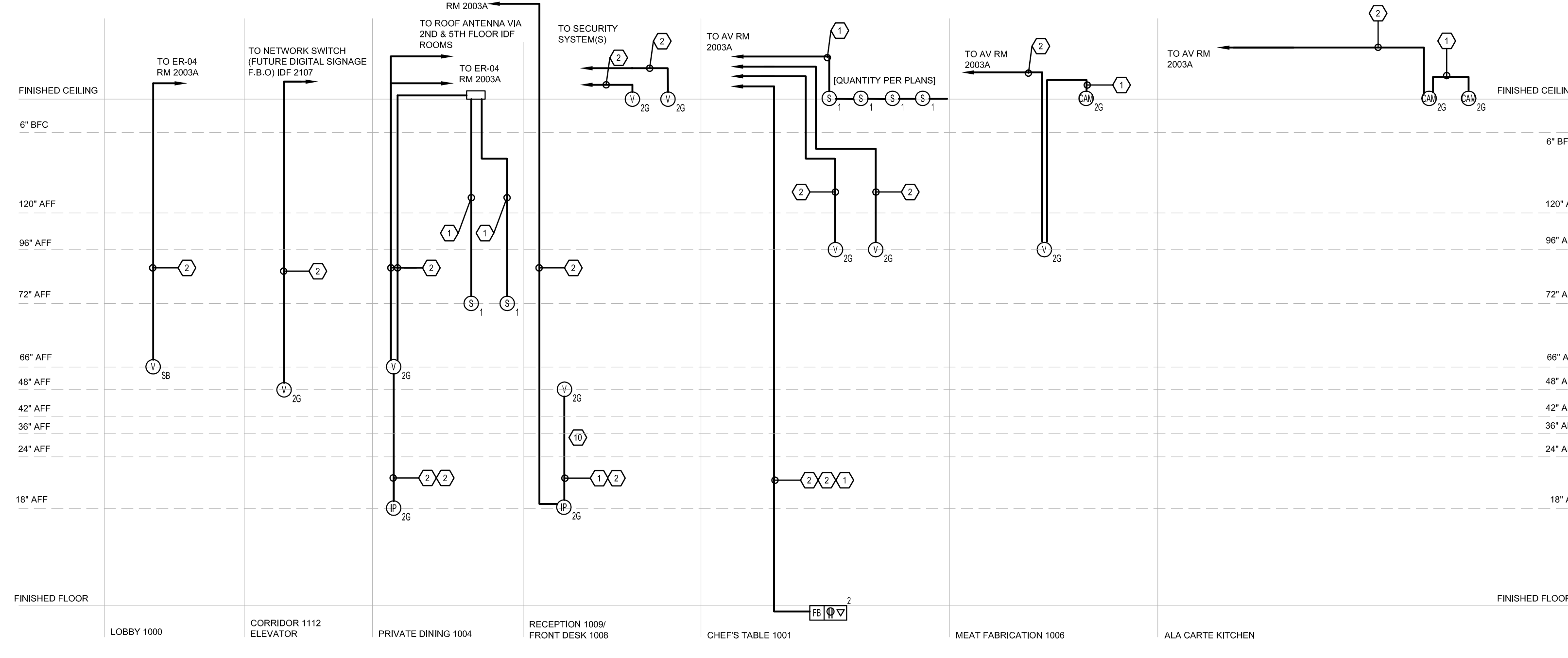
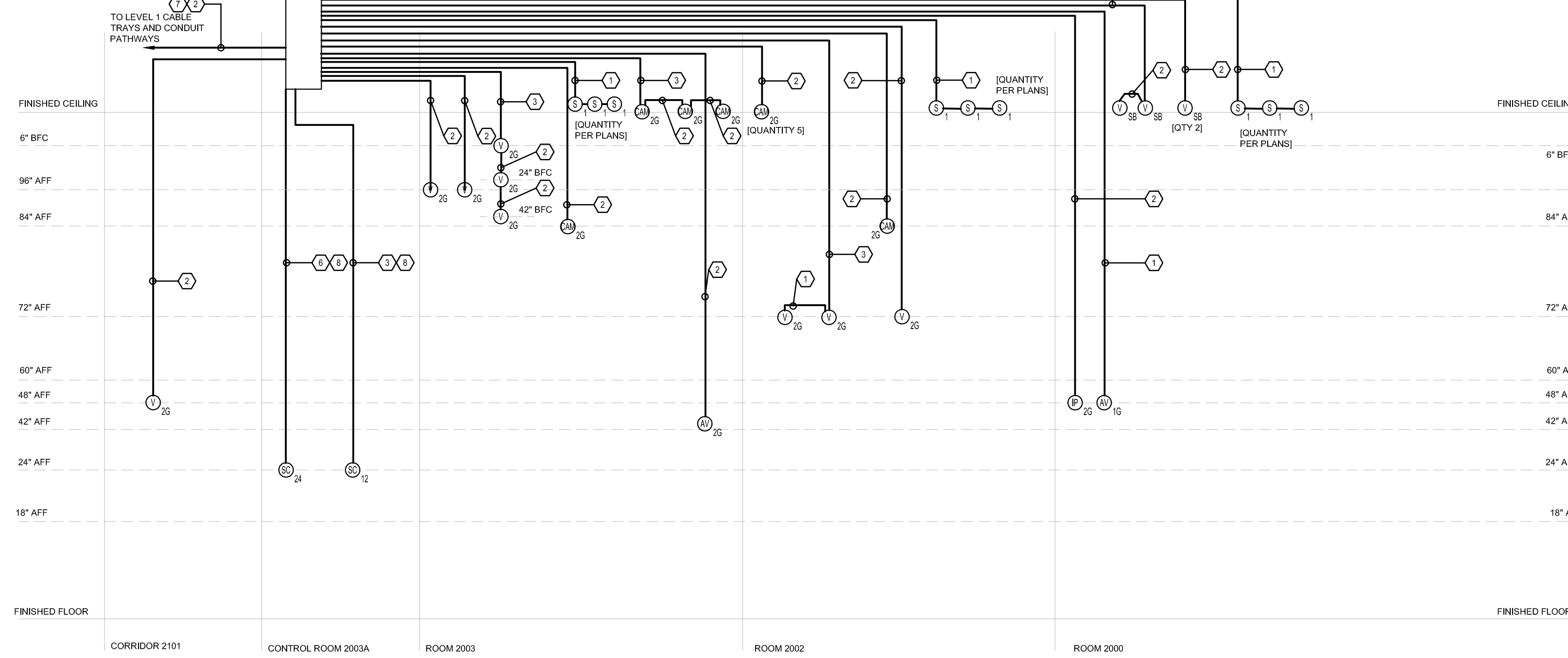
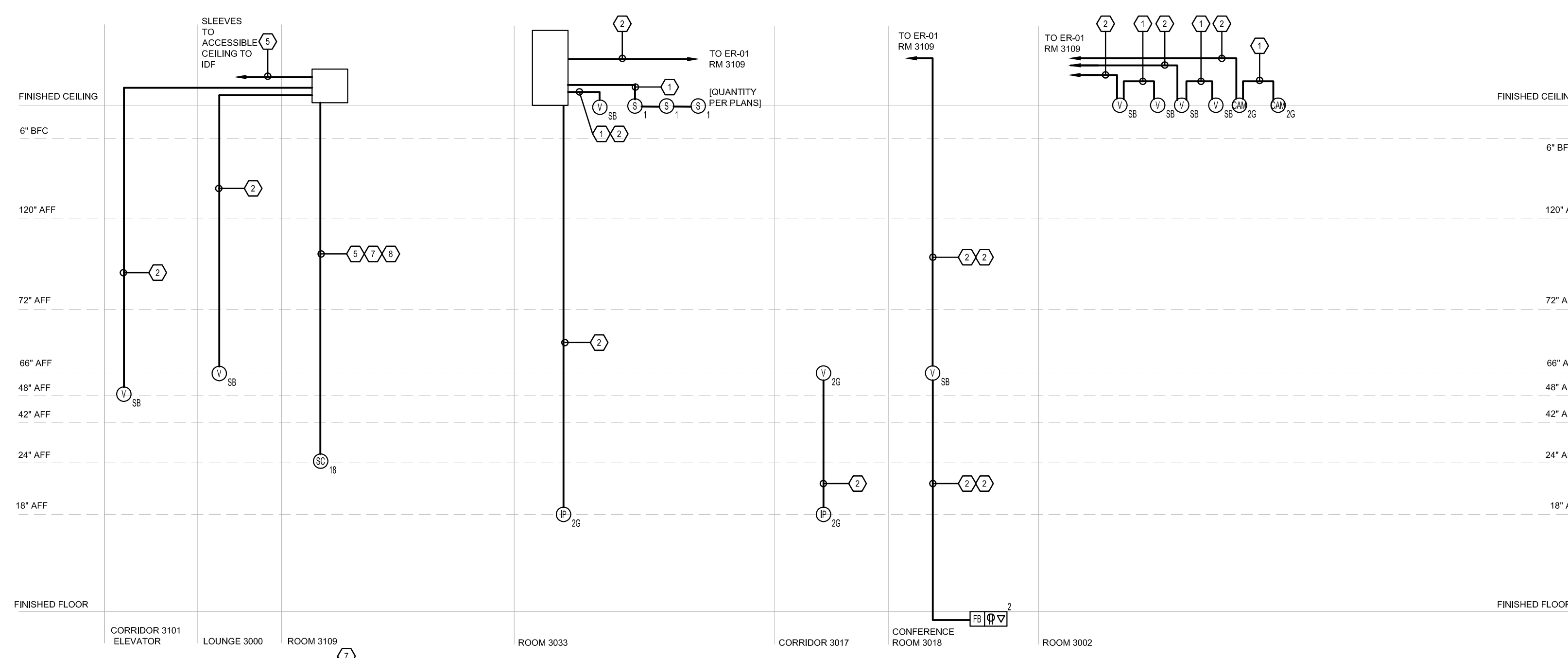
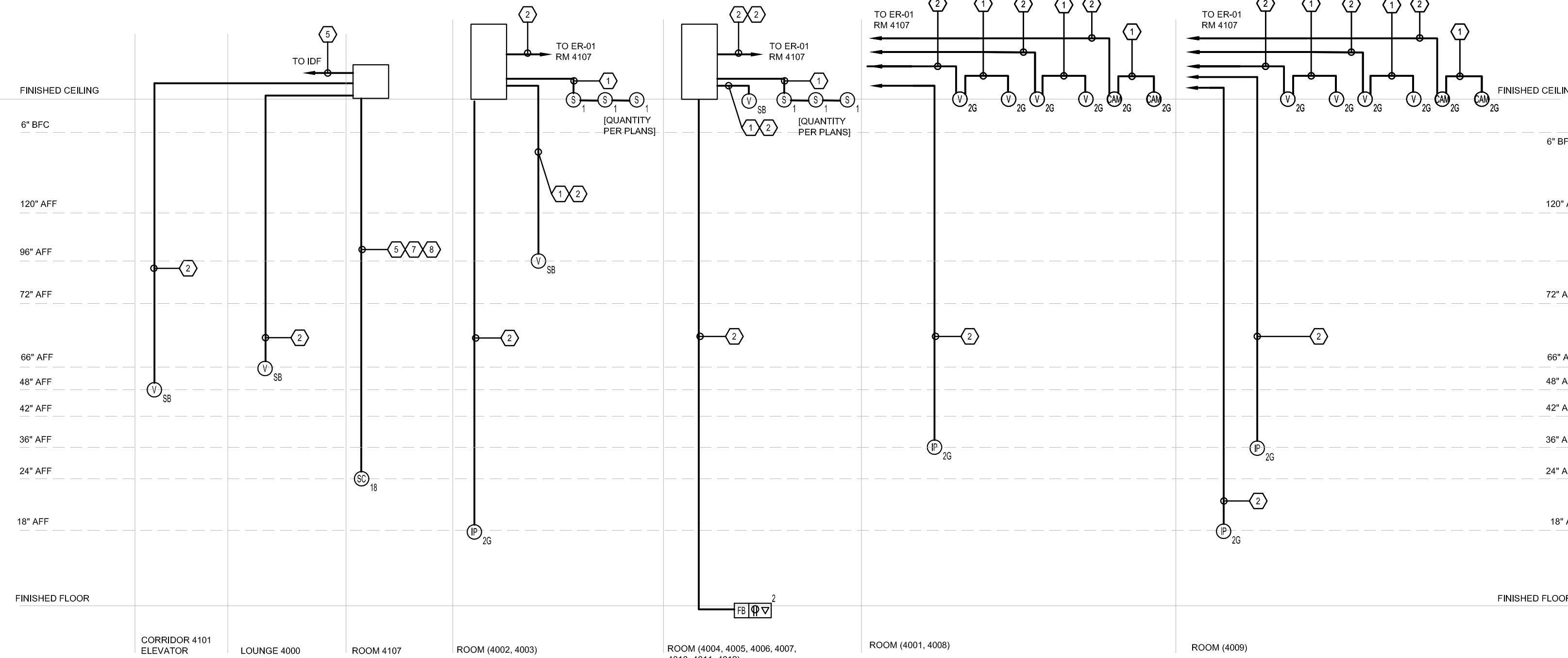
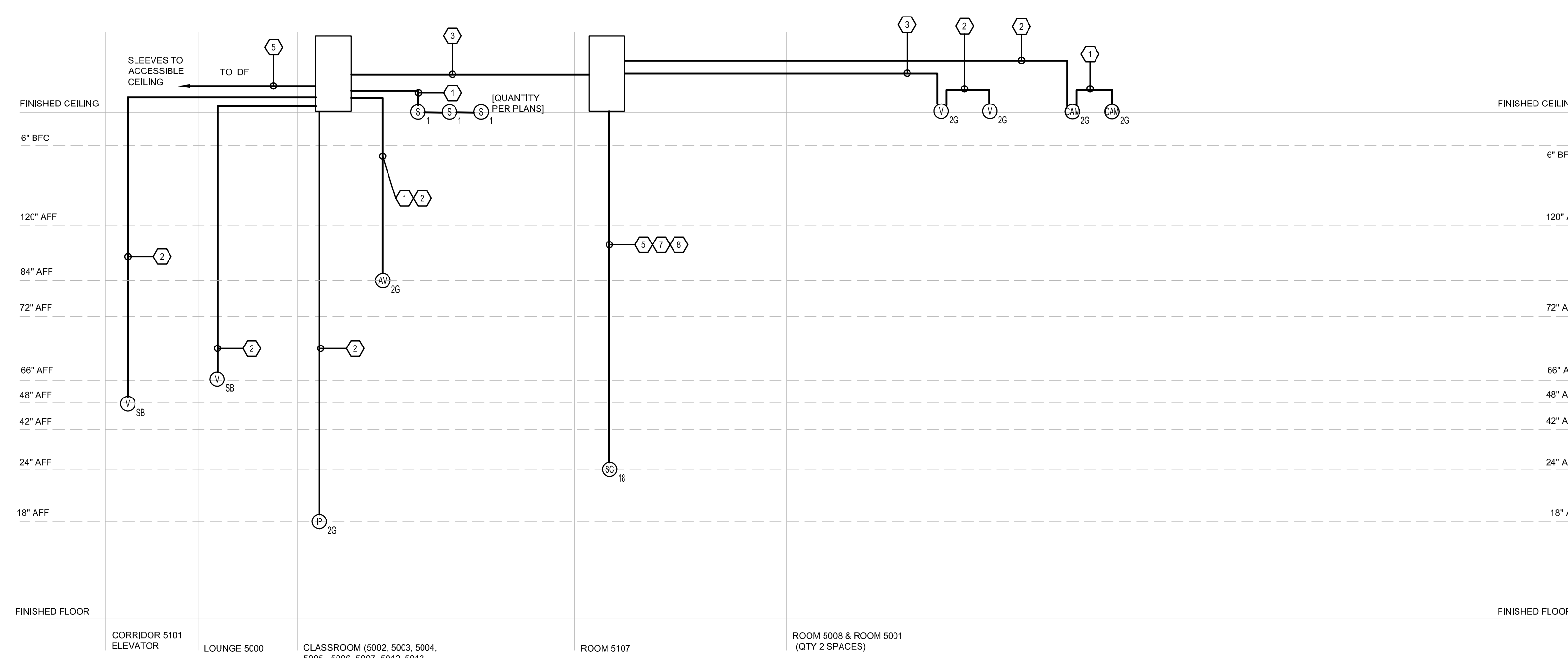
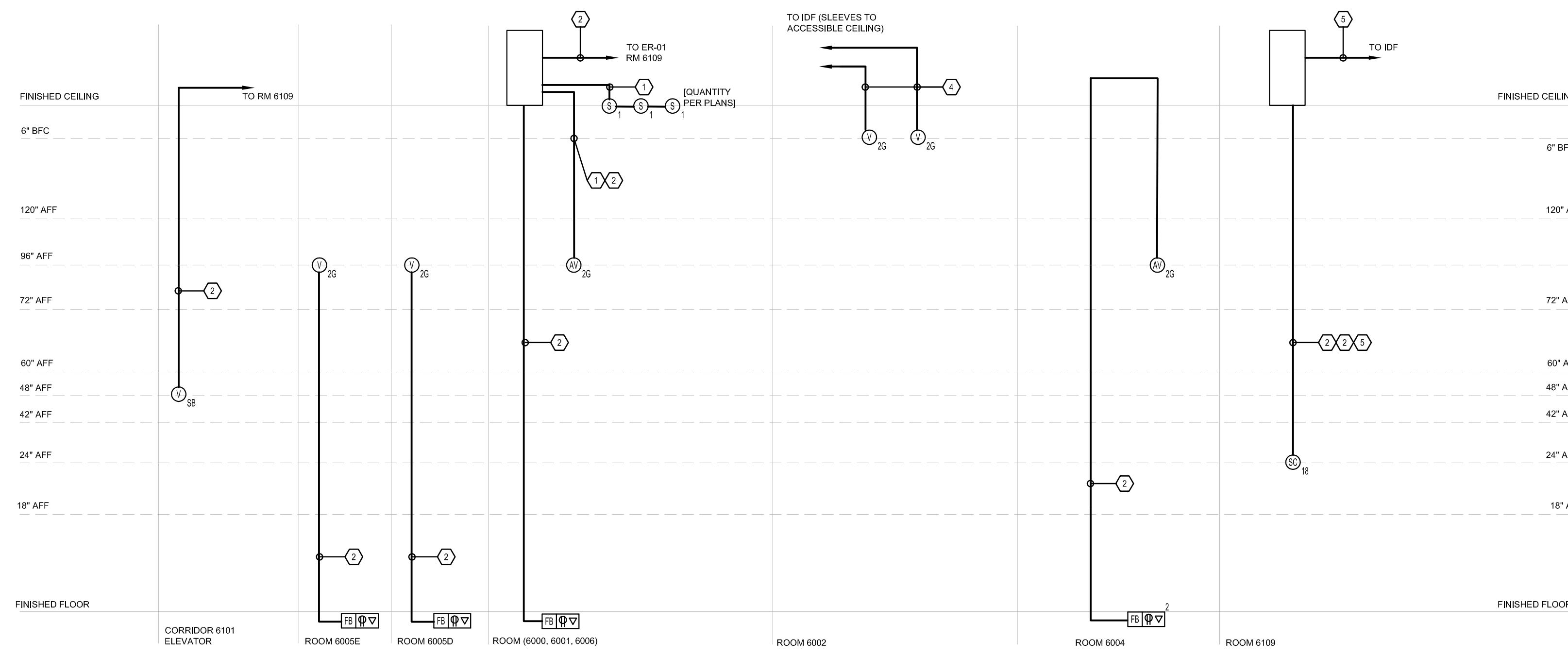

- GENERAL NOTES:**
1. CONDUITS INDICATE SIGNAL CABLE PATHS. USE STUBS TO ACCESSIBLE CEILING WHERE OPEN/PLENUM CABLE IS PERMITTED.
- RISER DIAGRAM NOTES:**
1. (1) 3/4" CONDUIT
 2. (1) 1" CONDUIT
 3. (1) 1-1/4" CONDUIT
 4. (1) 2" CONDUIT
 5. (2) 1-1/4" CONDUIT
 6. (5) 1-1/4" CONDUIT & (2) 2" CONDUIT
 7. (2) 2" CONDUIT
 8. (3) 1" CONDUIT
 9. (2) AV-2G POLE MOUNTED ON ROOM 1001 SIDE OF WALL
 10. ROUTE CONDUIT THRU MILLWORK
 11. MOUNT DISPLAYS TO ANGLED CEILING

NOTE: CONTRACTOR SHALL VERIFY ALL DIMENSIONS AND CONDITIONS AT JOB SITE AND BE FULLY RESPONSIBLE FOR SAME.

REVISIONS		
NO.	DESCRIPTION	DATE
01	REVISION A	09.16.14
02	REVISION B	09.16.14
03	REVISION C	10.29.14
04	AV 100% DD FINAL REVISION	11.24.15
05	100% CD FOR CONSTRUCTION	03.25.16

DRAWN	PREPARED
TL	RST
TRACED	APPROVED
TL	RST
CHECKED	APPROVED
TL	RST

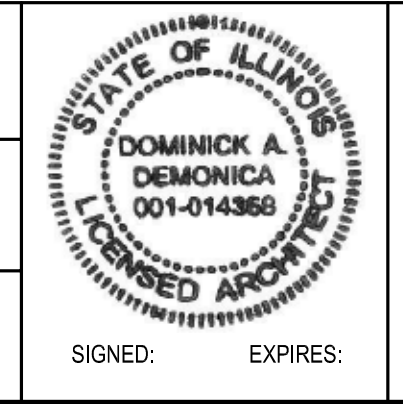

DKA DEMONICA KEMPER ARCHITECTS
 125 N. HALSTED STREET, SUITE 301
 CHICAGO, IL 60661
 P: 312.496.0000

KJW KJWW ENGINEERING
 1100 WARRENVILLE ROAD, #400W
 NAPERVILLE, IL 60563
 T: 312.559.4585

EFW E.F. WHITNEY, INC.
 568 ANN STREET
 BIRMINGHAM, MI 48009
 T: 248.644.0990

SM&W SHEN MILSOM WILKE
 2 N. RIVERSIDE PLAZA
 CHICAGO, IL 60606
 T: 312.559.4585

100% CD FOR CONSTRUCTION		PROJECT NO.
AUDIOVISUAL RISER DIAGRAMS		DATE
CITY CENTER CAMPUS		APRIL 21, 2016
JOLIET JUNIOR COLLEGE		SHEET NO.
TA500		

LOUDSPEAKER SCHEDULE (S)							
TYPE	MANUFACTURER	MODEL	MOUNTING	BACK CAN MODEL	SUPPORT HARDWARE/ YOKE/TILE BRIDGING	DEPTH, INSTALLED	NOTES
S-01	JBL	CTRL 26CT	N/A	N/A	N/A	8.3"	
S-02	JBL	CTRL 26DT	N/A	N/A	Atlas BMT95-9-7	Included with back can	
S-03	JBL	CTRL 64PT	N/A	N/A	N/A	N/A PENDANT	
S-04	EXTRON	FF220T-D3	CEILING TILE DROP IN				INCLUDE SAFETY CABLES AT FOUR CORNERS
S-05	INNOVOX	S2.1US	WALL SURFACE	N/A	N/A	1.75"	

FLAT PANEL DISPLAY SCHEDULE (FPD)							
TYPE	SCREEN SIZE	SPEAKERS	MOUNTING	GENERAL DIMENSIONS*	POWER	WEIGHT	NOTES
FPD-02	24"	INTEGRAL	WALL	14"x23"x1.18"	120VAC / 4A	11 LBS	
FPD-03	32"	INTEGRAL	WALL	18"x30"x2"	120VAC / 5A	18 LBS	
FPD-04	47"	INTEGRAL	WALL	25"x43"x3"	120VAC / 1A	37 LBS	
FPD-05	55"	INTEGRAL	WALL	28"x50"x3"	120VAC / 1.2A	56 LBS	
FPD-06	60"	INTEGRAL	WALL	32"x55"x2"	120VAC / 1.5A	71 LBS	
FPD-07	70"	INTEGRAL	WALL	37"x63"x2"	120VAC / 2A	95 LBS	
FPD-08	80"	INTEGRAL	WALL	43"x73"x4"	120VAC / 2.5A	128 LBS	

GENERAL NOTES:
A. *DISPLAY DIMENSIONS REFLECT A CROSS SECTION OF MANUFACTURERS AND IS NOT INDICATIVE OF A PARTICULAR MANUFACTURER OR MODEL. DIMENSION IS THE MAXIMUM ACROSS COMMON MODELS IN A GIVEN SCREEN SIZE.
B. REFER TO RESPECTIVE ARCHITECTURAL AND INTERIORS ELEVATIONS FOR EXACT LOCATION OF SCREEN.
C. AV INTEGRATOR TO COORDINATE WITH ARCHITECT AND OWNER FOR EXACT LOCATIONS OF FPD'S

MANUAL FRONT PROJECTION SCREEN SCHEDULE (MPS)									
TYPE	MANUFACTURER	MODEL	SCREEN FABRIC	SCREEN SIZE	EXTRA DROP	MOUNTING	CASE DIMENSIONS	WEIGHT	NOTES
MPS-01	Da Lite	35441	Da Matte	60"x96"		Wall	7-3/4"x105-1/2"x6-3/8"	95 lbs	1
MPS-02	Da Lite	20897	Da Matte	65"x104"		Ceiling	7-3/4"x113-1/2"x6-3/8"	95lbs	1

GENERAL NOTES:
A. SCREEN SHALL BE TENSIONED AND SEAMLESS, WITHOUT PERFORATIONS. SCREENS SHALL HAVE BLACK BACKING IN ORDER TO BLOCK AMBIENT LIGHT.
B. REFER TO RESPECTIVE ARCHITECTURAL PLAN FOR LOCATION OF SCREEN.
C. SEE SPECIFICATIONS FOR ADDITIONAL INFORMATION. CASE SIZE AND LOCATION TO BE VERIFIED IN FIELD.
D. MANUAL PROJECTION SCREENS SHALL BE PURCHASED BY OWNER AND INSTALLED BY CDB GENERAL CONTRACTOR

ELECTRIC FRONT PROJECTION SCREEN SCHEDULE (EPS)											
TYPE	MANUFACTURER	MODEL	SCREEN FABRIC	SCREEN SIZE	EXTRA DROP	MOUNTING	CASE DIMENSIONS	POWER REQUIREMENT	LOW VOLTAGE CONTROL MODEL NUMBER	WEIGHT	NOTES
EPS-01	Da Lite	20849LS	Da Matte	65"x104"	STD 12"	REC CEIL	7-3/4"x122-1/2"x6-3/8"	120V 2.4A	#40973	114 LBS	1,2

GENERAL NOTES:
A. SCREEN SHALL BE TENSIONED AND SEAMLESS, WITHOUT PERFORATIONS. SCREENS SHALL HAVE BLACK BACKING IN ORDER TO BLOCK AMBIENT LIGHT.
B. REFER TO RESPECTIVE ARCHITECTURAL PLAN FOR LOCATION OF SCREEN.
C. SEE SPECIFICATIONS FOR ADDITIONAL INFORMATION. CASE SIZE AND LOCATION TO BE VERIFIED IN FIELD.
NOTES:
1. PROVIDE LOW VOLTAGE MULTI-CONTROL NEMA 1 ENCLOSURE AND LOW VOLTAGE CONTROL WIRING SYSTEM.
2. PROJECTION SCREEN TO BE PURCHASED THROUGH JJC. GC TO INSTALL CHASSIS; AV INTEGRATOR TO INSTALL SCREEN AND ROLLER

SPECIALTY BACKBOX SCHEDULE (SB)							
TYPE	LOCATION	EQUIPMENT TYPE	MANUFACTURER	MODEL	DETAIL SHEET	MOUNTING	NOTES
SB-01	WALL RECESSED	IN-WALL DISPLAY STORAGE BOX WITH DATA AND POWER	CHEIF	PAC2S3FCW	TAB00	IN WALL	V-SB

NOTES:
1. MOUNT PROVIDED AND INSTALLED BY GC. POWER AND RACEWAY/BOXES BY EC





FLOORBOX SCHEDULE (FB)										
TYPE	MANUFACTURER	MODEL	COVER	AV	CONFIGURATION	DIMENSIONS	DEPTH	NOTES		
FB-01	WIREMOLD	EFBS-OG	(NOTE 1)	4-GANG	1-GANG 1-GANG	15-1/4" x 11-1/4"	4"	1,2,4		
FB-02	WIREMOLD	8ATC	(NOTE 1)	6-GANG	1-GANG 1-GANG	16-1/4" x 9-1/4"	3-1/2"	1,3		

NOTES:

EQUIPMENT SCHEDULE (EQS)			
NO.	LOCATION	EQUIPMENT TYPE	MOUNTING
CAM-01	CEILING	PTZ CAMERA	CEILING
CAM-02	CEILING	FIXED CAMERA	CEILING
CAM-03	WALL	PTZ CAMERA	WALL MOUNT
CAM-04	INSTR STATION	PTZ CAMERA WITH ARTICULATING ARM	THROUGH SURFACE
CAM-05	INSTR STATION	FIXED CAMERA WITH ARTICULATING ARM	THROUGH SURFACE
EPS-01	CEILING	ELECTRIC PROJECTION SCREEN	FLUSH MOUNT IN CEILING
ER-01	AV CLOSET	44RU EQUIPMENT RACK	FLOOR MOUNT
ER-01-F	AV CLOSET	FUTURE 44RU EQUIPMENT RACK	FLOOR MOUNT
ER-03	AV CTRL RM	12RU EQUIPMENT RACK	UNDER COUNTER TOP
ER-04	AV CTRL RM	44RU EQUIPMENT RACK	FLOOR MOUNT- ON CASTERS
FB-01	FLOOR	AV FLOOR BOX	FLUSH MOUNT
FB-02	FLOOR	AV FLOOR BOX - POKE THROUGH	FLUSH MOUNT
FPD-XX-F		FUTURE FLAT PANEL DISPLAY	RECESSED WALL
FPD-02		FLAT PANEL DISPLAY 24"	POLE MOUNT
FPD-03		FLAT PANEL DISPLAY 32"	RECESSED WALL
FPD-04		FLAT PANEL DISPLAY 47"	VARIES
FPD-05		FLAT PANEL DISPLAY 55"	VARIES
FPD-06		FLAT PANEL DISPLAY 65"	VARIES
FPD-07		FLAT PANEL DISPLAY 70"	VARIES
FPD-08	LOBBY	FLAT PANEL DISPLAY 80"	VARIES
KS-01	STUDENT SERV	KEY SWITCH FOR ELECTRIC PROJECTION SCREEN	WALL
IP-01	WALL	AV INPUT CONNECTIVITY PANEL (HDMI) QTY 2	FLUSH MOUNT
IP-02	WALL	AV INPUT CONNECTIVITY PANEL (HDMI) QTY 2	FLUSH MOUNT
IP-03	FLOOR BOX	AV INPUT CONNECTIVITY PANEL (HDMI) QTY 1	
MPS-01	WALL	MANUAL PROJECTION SCREEN 60X96	WALL MOUNT
MPS-02	WALL	MANUAL PROJECTION SCREEN 65X104	WALL MOUNT
RX-01		HDBT RECEIVER (1 GANG DEVICE)	WALL / FLOOR BOX
RX-02		HDBT RECEIVER	BEHIND DISPLAY / IN SPEC BOX
S-01		CEILING SPEAKER	CEILING TILE MOUNT
S-02		CEILING SPEAKER WITH BACK CAN	GYPSTUM CEILING MOUNT
S-03	CHEF'S TABLE	PENDANT SPEAKER	HUNG FROM CEILING DECK
S-04	PRIVATE DINING	COLUMNAR SPEAKER FOR FLAT PANEL DISPLAY	WALL
TP-01	HOSTESS	TOUCH CONTROL PANEL - 7" DIAG DISPLAY	HOSTESS STAND TABLE TOP
TP-02	CULINARY LABS	TABLET CONTROL SURFACE	TABLE TOP QUICK RELEASE MOUNT
TX-01		HDBT TRANSMITTER PANEL	WALL / FLOOR BOX
TX-02		HDBT TRANSMITTER	EQUIP RACK / SPECIALTY BBOX
VP-01	STUDENT SERV	VIDEO PROJECTOR	CEILING MOUNT
VP-02	CLASSROOMS	VIDEO PROJECTOR - SHORT THROW	WALL MOUNT WITH INCLUDED ARM
VP-03	RM 5004	VIDEO PROJECTOR	CEILING MOUNT
WAP		WIRELESS ACCESS POINT	SURFACE CEILING
WM-1	EQUIP RACK	WIRELESS MICROPHONE RECEIVER	RACK MOUNT

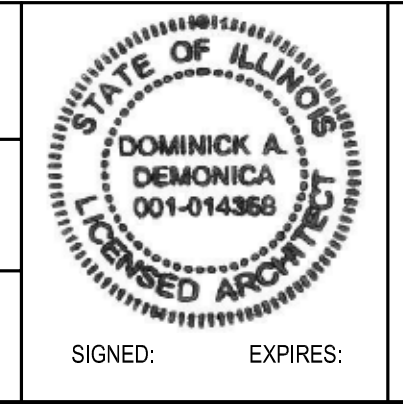
JOLIET JUNIOR COLLEGE CITY CENTER					
Multimedia Systems Power & Heat Load Calculations					
4/11/2016					
		Power (Watts)		Heat Load (BTU/Hr)	
ROOM NAME	Location	PEAK	QUESCENT	PEAK	QUESCENT
LOBBY / RECEPTION / CORRIDORS	In-Room	2,490	2,004	6,813	6,854
	In-Equip. Rack	0	0	0	0
CHEF'S TABLE	In-Room	630	16	1,724	55
	In-Equip. Rack	0	0	0	0
MEAT FABRICATION	In-Room	175	7	479	24
	In-Equip. Rack	0	0	0	0
DEMONSTRATION CLASSROOM	In-Room	560	6	1,532	21
	In-Equip. Rack	0	0	0	0
DEMO CLASS CONTROL ROOM	In-Room	800	285	2,189	975
	In-Equip. Rack	2,790	295	7,633	1,009
COMPETITION LAB	In-Room	0	0	0	0
	In-Equip. Rack	0	0	0	0
STUDENT DINING	In-Room	1,005	9	2,750	31
	In-Equip. Rack	0	0	0	0
LOUNGE	In-Room	200	2	547	7
	In-Equip. Rack	0	0	0	0
CONFERENCE ROOM	In-Room	330	2	903	7
	In-Equip. Rack	0	0	0	0
AV RACK ROOM	In-Room	800	285	2,189	975
	In-Equip. Rack	2,790	295	7,633	1,009
GARDE MANGER	In-Room	620	269	1,696	920
	In-Equip. Rack	0	0	0	0
CLASSROOM	In-Room	475	20	1,300	68
	In-Equip. Rack	0	0	0	0
#REF!	In-Room	0	0	0	0
	In-Equip. Rack	0	0	0	0
COMPUTER CLASSROOM / MATH LAB / ENGLISH LAB	In-Room	475	20	1,300	68
	In-Equip. Rack	0	0	0	0
LAB	In-Room	610	21	1,669	72
	In-Equip. Rack	0	0	0	0
PRODUCTION LAB	In-Room	480	29	1,313	99
	In-Equip. Rack	0	0	0	0
TESTING CENTER / TUTORING	In-Room	745	9	2,038	31
	In-Equip. Rack	0	0	0	0
GROUP STUDY	In-Room	290	0	547	0
	In-Equip. Rack	0	0	0	0

NOTE: CONTRACTOR SHALL VERIFY ALL DIMENSIONS AND CONDITIONS AT JOB SITE AND BE FULLY RESPONSIBLE FOR SAME.

REVISIONS <table border="1"> <thead> <tr> <th>NO.</th> <th>DESCRIPTION</th> <th>DATE</th> </tr> </thead> <tbody> <tr><td>01</td><td>REVISION A</td><td>09.16.14</td></tr> <tr><td>02</td><td>REVISION B</td><td>09.16.14</td></tr> <tr><td>03</td><td>REVISION C</td><td>10.29.14</td></tr> <tr><td>04</td><td>AV 100% DD FINAL REVISION</td><td>11.24.15</td></tr> <tr><td>05</td><td>100% CD FOR CONSTRUCTION</td><td>03.25.16</td></tr> </tbody> </table>		NO.	DESCRIPTION	DATE	01	REVISION A	09.16.14	02	REVISION B	09.16.14	03	REVISION C	10.29.14	04	AV 100% DD FINAL REVISION	11.24.15	05	100% CD FOR CONSTRUCTION	03.25.16	DRAWN: TL PREPARED: RST TRACED: TL CHECKED: TL	APPROVED: RST APPROVED: RST APPROVED: RST	 DOMINICK A. DEMONICA 001-014360 SIGNED: _____ EXPIRES: _____	 DEMONICA KEMPER ARCHITECTS 125 N. HALSTED STREET, SUITE 301 CHICAGO, IL 60661 P: 312.496.0000	 KJW ENGINEERING 1100 WARRENVILLE ROAD, #400W NAPERVILLE, IL 60563 T: 312.559.4585	 E.F. WHITNEY, INC. 568 ANN STREET BIRMINGHAM, MI 48009 T: 248.644.0990	 SHEN MILSON WILKE 2 N. RIVERSIDE PLAZA CHICAGO, IL 60606 T: 312.559.4585	100% CD FOR CONSTRUCTION AUDIOVISUAL SCHEDULES CITY CENTER CAMPUS JOLIET JUNIOR COLLEGE	PROJECT NO. DATE: APRIL 21, 2016 SHEET NO. TA600
NO.	DESCRIPTION	DATE																										
01	REVISION A	09.16.14																										
02	REVISION B	09.16.14																										
03	REVISION C	10.29.14																										
04	AV 100% DD FINAL REVISION	11.24.15																										
05	100% CD FOR CONSTRUCTION	03.25.16																										

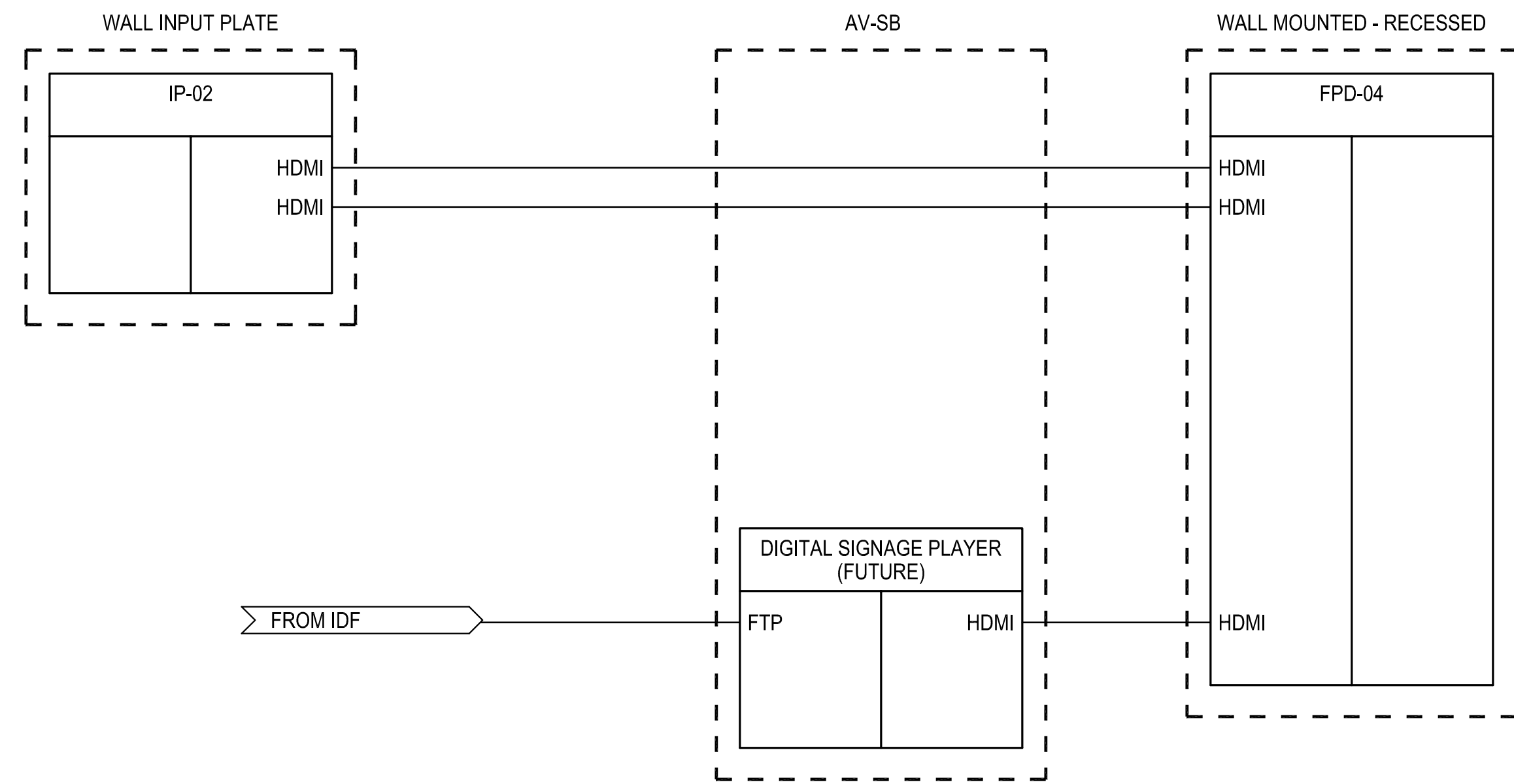

5 AUDIOVISUAL SIGNAL FLOW DIAGRAM - RECEPTION RM 1009
SCALE: NTS

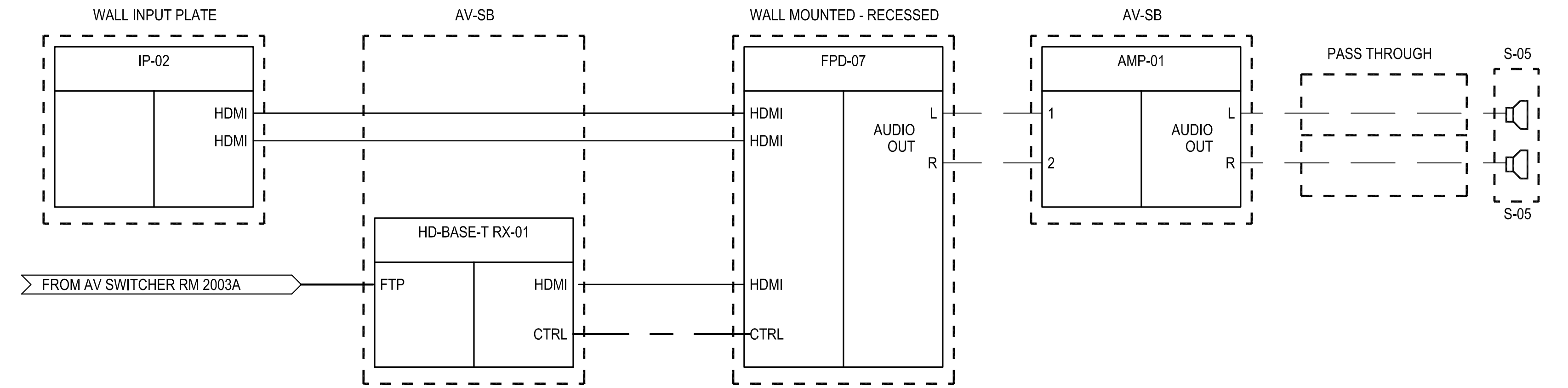

2 AUDIOVISUAL SIGNAL FLOW DIAGRAM - PRIVATE DINING - RM 1004
SCALE: NTS

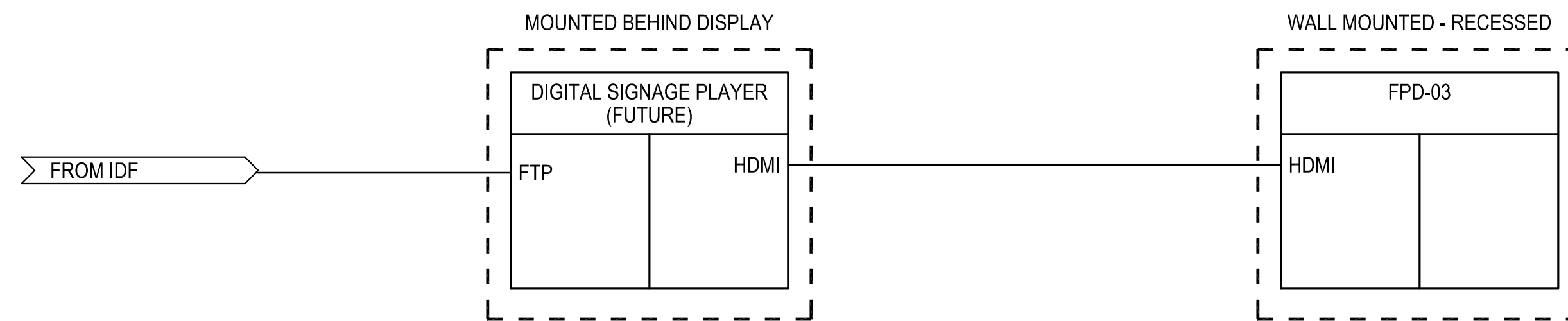

4 AUDIOVISUAL SIGNAL FLOW DIAGRAM - CORRIDOR RM 1112 (ELEVATOR)
SCALE: NTS

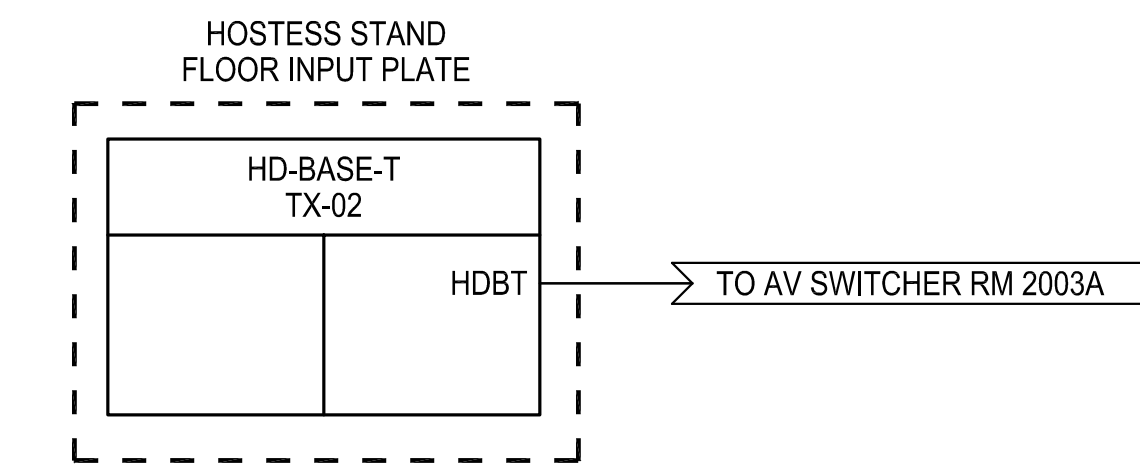

4 AUDIOVISUAL SIGNAL FLOW DIAGRAM - CORRIDOR RM 1112 (ELEVATOR)
SCALE: NTS

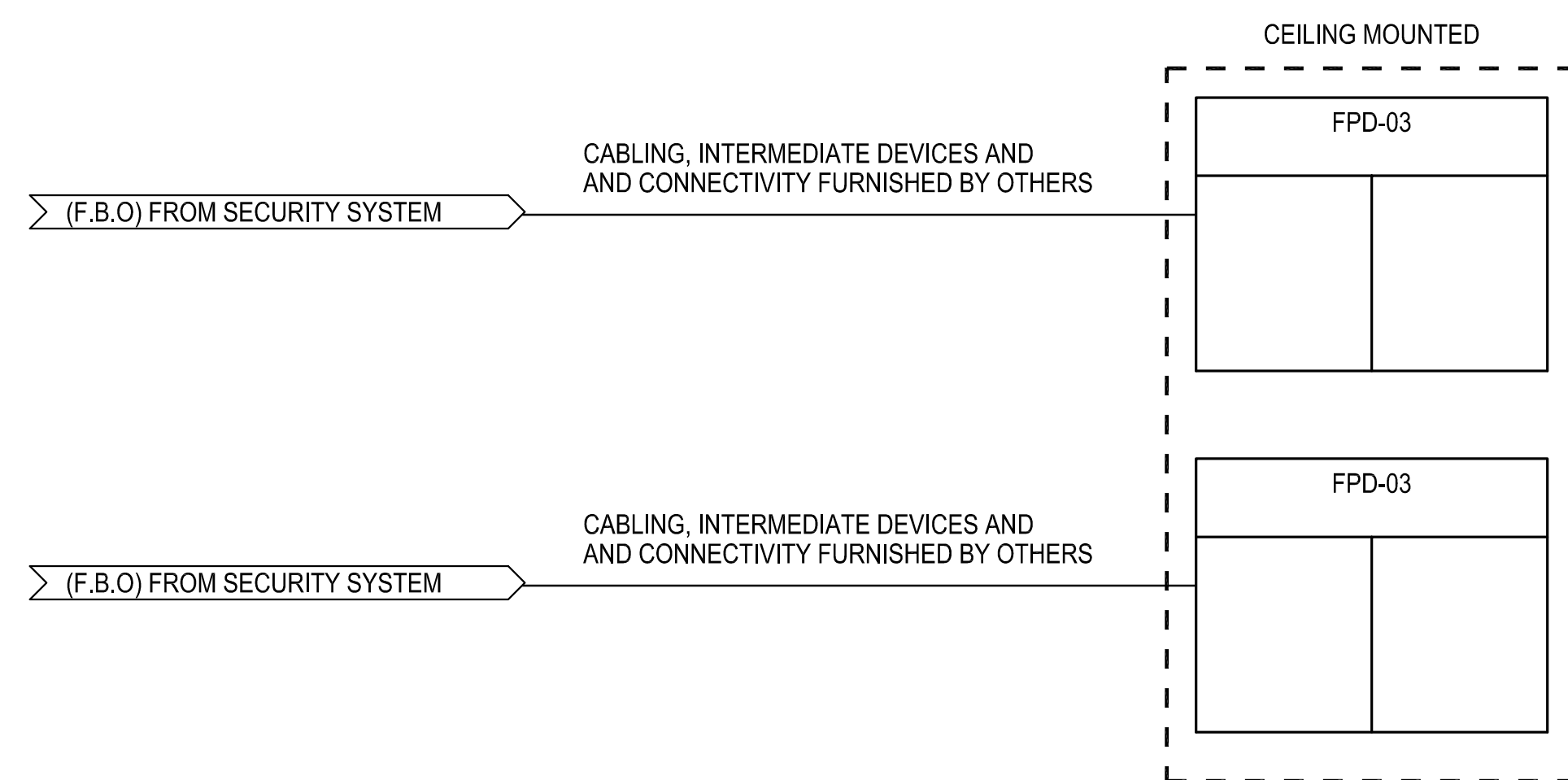

3 AUDIOVISUAL SIGNAL FLOW DIAGRAM - FRONT DESK RM 1008
SCALE: NTS

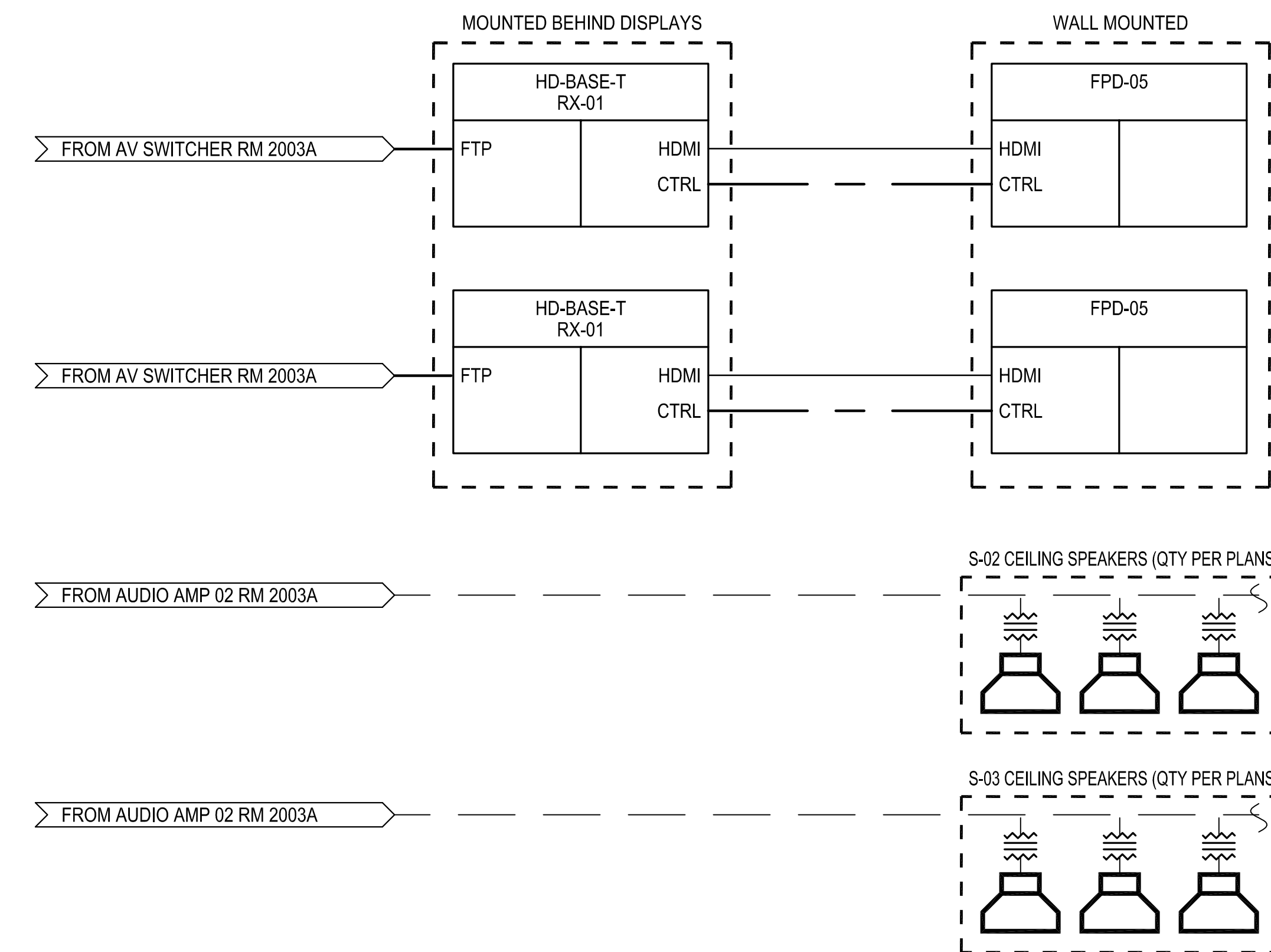

1 AUDIOVISUAL SIGNAL FLOW DIAGRAM - CHEF'S TABLE - RM 1001
SCALE: NTS

NOTE: CONTRACTOR SHALL VERIFY ALL DIMENSIONS AND CONDITIONS AT JOB SITE AND BE FULLY RESPONSIBLE FOR SAME.

REVISIONS			DRAWN	PREPARED	100% CD FOR CONSTRUCTION				PROJECT NO.	
NO.	DESCRIPTION	DATE	TL	RST	AUDIOVISUAL SIGNAL FLOW DIAGRAMS				PROJECT NO.	
01	REVISION A	09.16.14	TRACED	APPROVED	CITY CENTER CAMPUS JOLIET JUNIOR COLLEGE				DATE	
02	REVISION B	09.16.14	TL	RST					APRIL 21, 2016	
03	REVISION C	10.29.14	TL	RST					SHEET NO.	
04	AV 100% DD FINAL REVISION	11.24.15	CHECKED	APPROVED					TA701	
05	100% CD FOR CONSTRUCTION	03.25.16	TL	RST						
			DEMONICA KEMPER ARCHITECTS 125 N. HALSTED STREET, SUITE 301 CHICAGO, IL 60661 P: 312.496.0000		KJWW ENGINEERING 1100 WARRENVILLE ROAD, #400W NAPERVILLE, IL 60563 T: 312.559.4585		E.F. WHITNEY, INC. 568 ANN STREET BIRMINGHAM, MI 48009 T: 248.644.0990		SHEN MILSOM WILKE LLC 2 N. RIVERSIDE PLAZA CHICAGO, IL 60606 T: 312.559.4585	

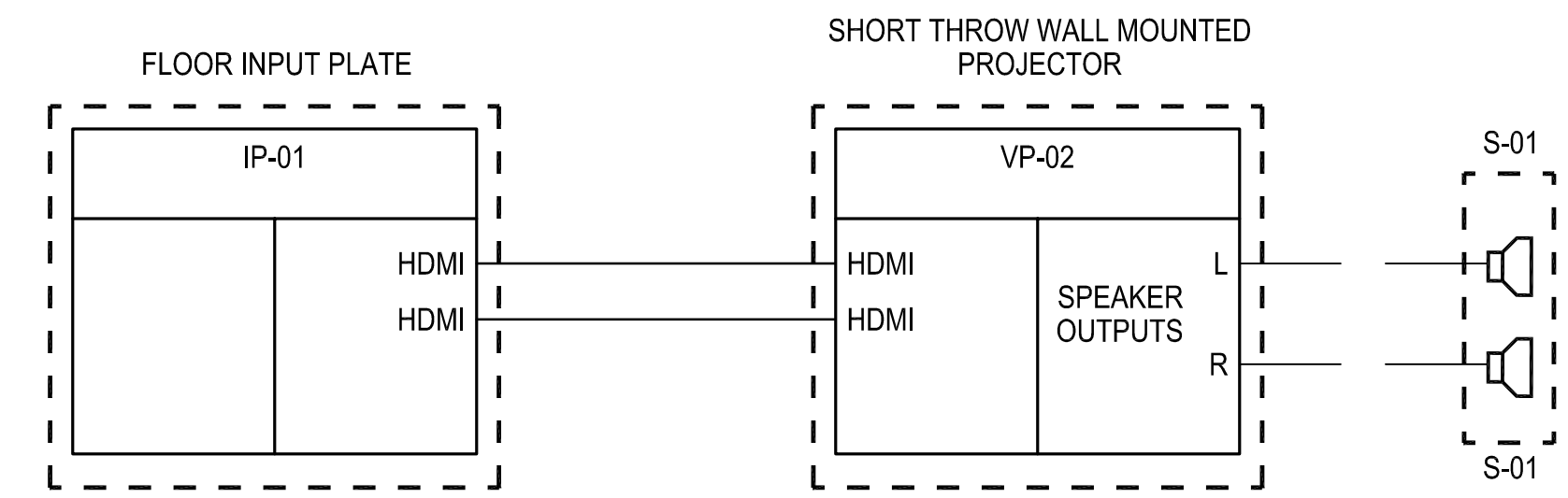

3 AUDIOVISUAL SIGNAL FLOW DIAGRAM - TUTORING RM 6004
SCALE: NTS

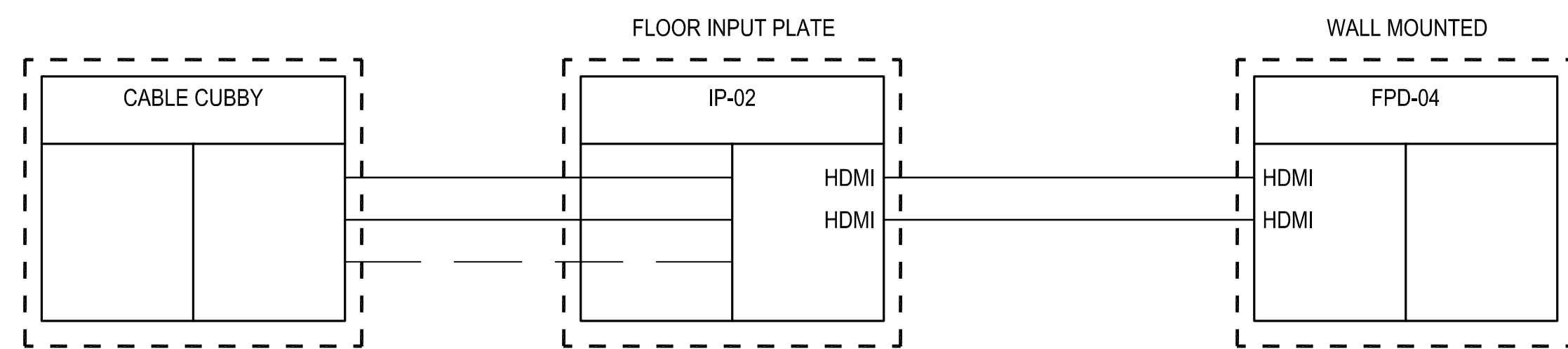

5 AUDIOVISUAL SIGNAL FLOW DIAGRAM - RM 3018 CONFERENCE ROOM
SCALE: NTS

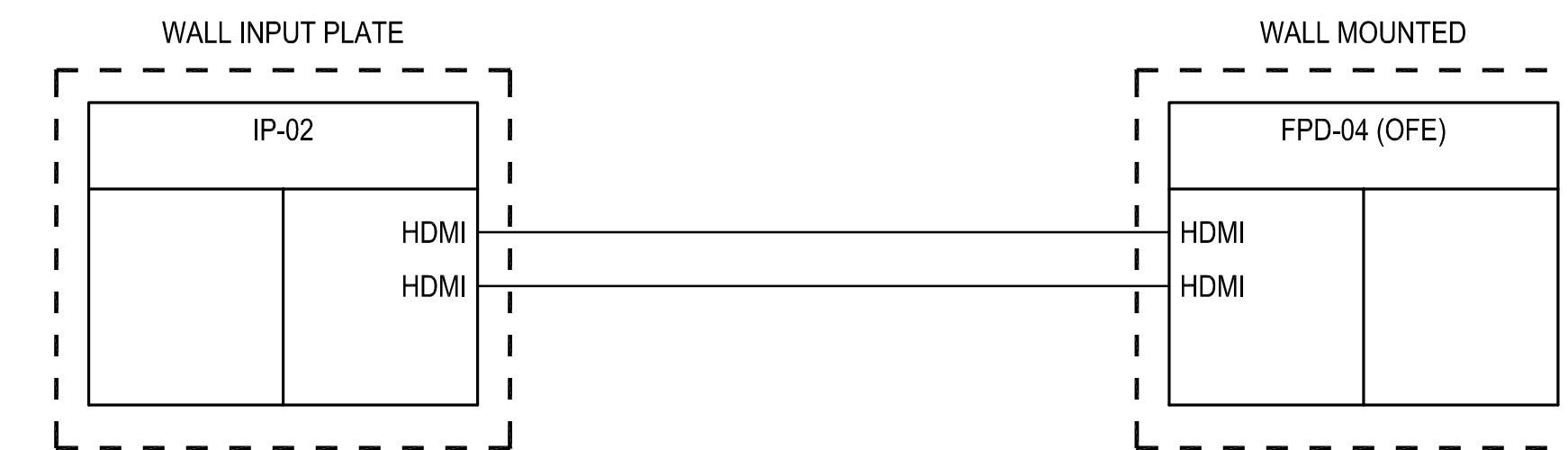

2 AUDIOVISUAL SIGNAL FLOW DIAGRAM - CORRIDOR 3017
SCALE: NTS

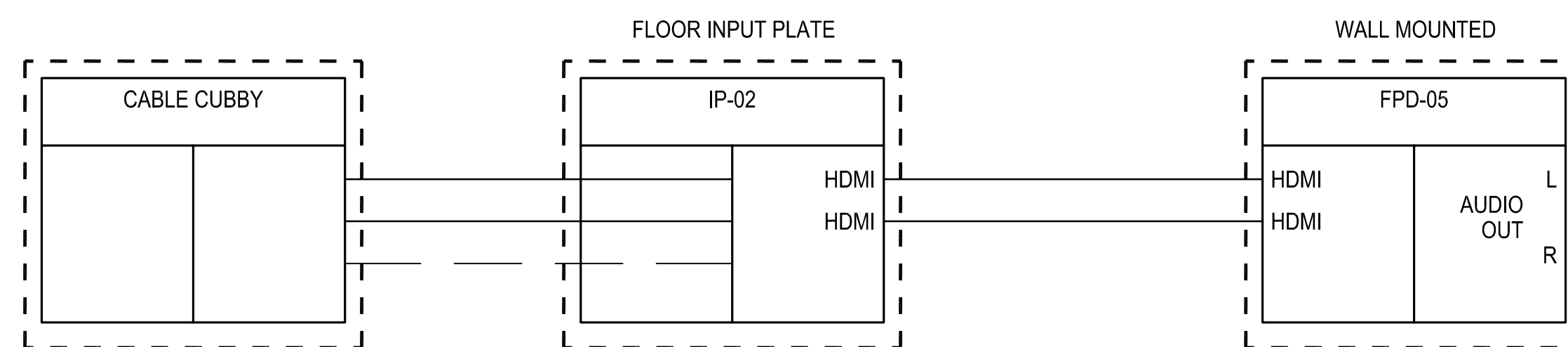

4 AUDIOVISUAL SIGNAL FLOW DIAGRAM - GROUP STUDY ROOMS 6005D AND 6005E
SCALE: NTS

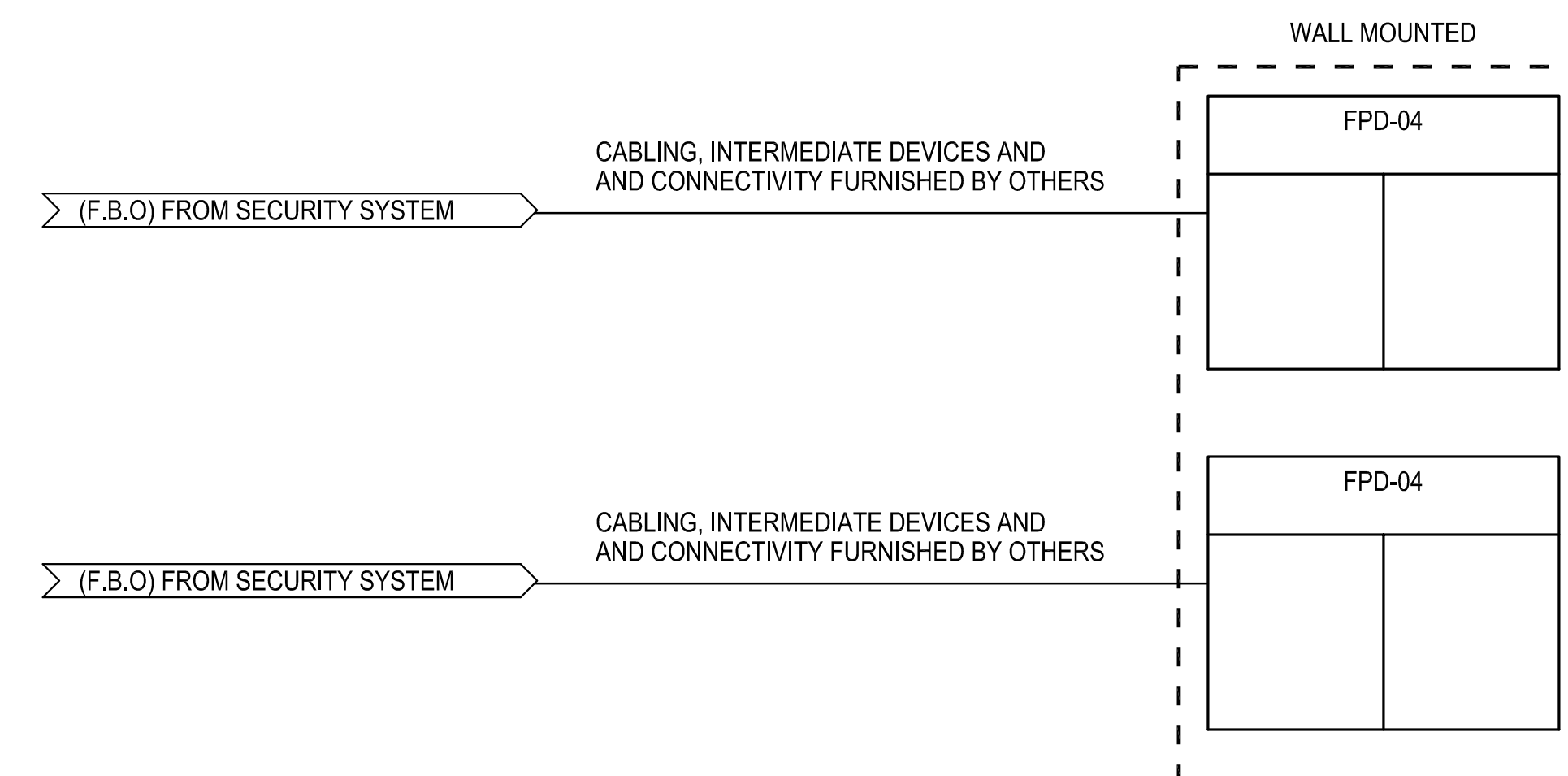

1 AUDIOVISUAL SIGNAL FLOW DIAGRAM - TESTING CENTER RM 6002
SCALE: NTS

NOTE: CONTRACTOR SHALL VERIFY ALL DIMENSIONS AND CONDITIONS AT JOB SITE AND BE FULLY RESPONSIBLE FOR SAME.

REVISIONS		
NO.	DESCRIPTION	DATE
01	REVISION A	09.16.14
02	REVISION B	09.16.14
03	REVISION C	10.29.14
04	AV 100% DD FINAL REVISION	11.24.15
05	100% CD FOR CONSTRUCTION	03.25.16

DRAWN	PREPARED
TL	RST
TRACED	APPROVED
TL	RST
CHECKED	APPROVED
TL	RST

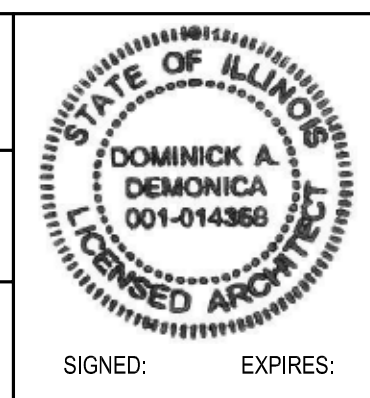

dkA DEMONICK A. DEMONICA ARCHITECTS
125 N. HALSTED STREET, SUITE 301
CHICAGO, IL 60661
P: 312.496.0000

KJWW KJWW ENGINEERING
1100 WARRENVILLE ROAD, #400W
NAPERVILLE, IL 60563
T: 312.559.4585

E.F.W. E.F. WHITNEY, INC.
568 ANN STREET
BIRMINGHAM, MI 48009
T: 248.644.0990

SM&W SHEN MILSOM WILKE LLC
2 N. RIVERSIDE PLAZA
CHICAGO, IL 60606
T: 312.559.4585

100% CD FOR CONSTRUCTION		PROJECT NO.
AUDIOVISUAL SIGNAL FLOW DIAGRAMS		DATE APRIL 21, 2016
CITY CENTER CAMPUS JOLIET JUNIOR COLLEGE		SHEET NO. TA702

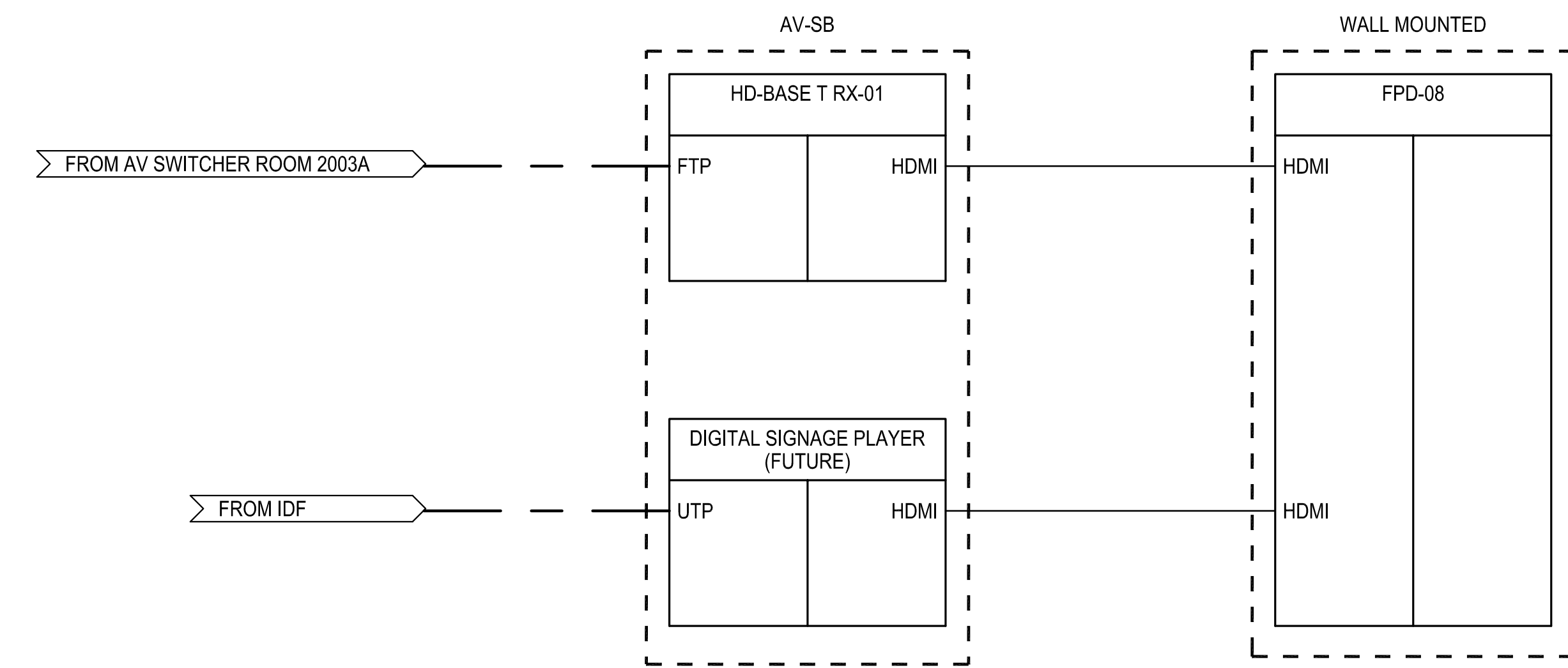

3 AUDIOVISUAL SIGNAL FLOW DIAGRAM - LOBBY 1000
SCALE: NTS

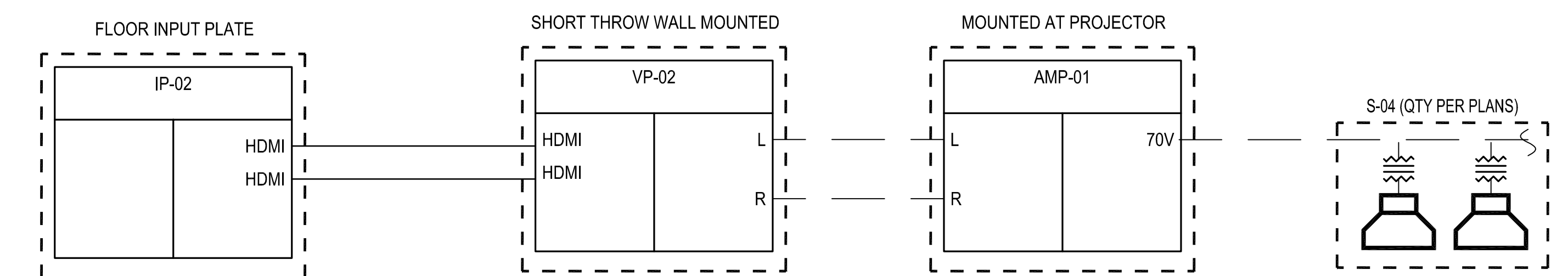

2 AUDIOVISUAL SIGNAL FLOW DIAGRAM - CLASSROOM TYPE 2 (4004,4005, 4006, 4007, 4010, 4011, 4012)
SCALE: NTS

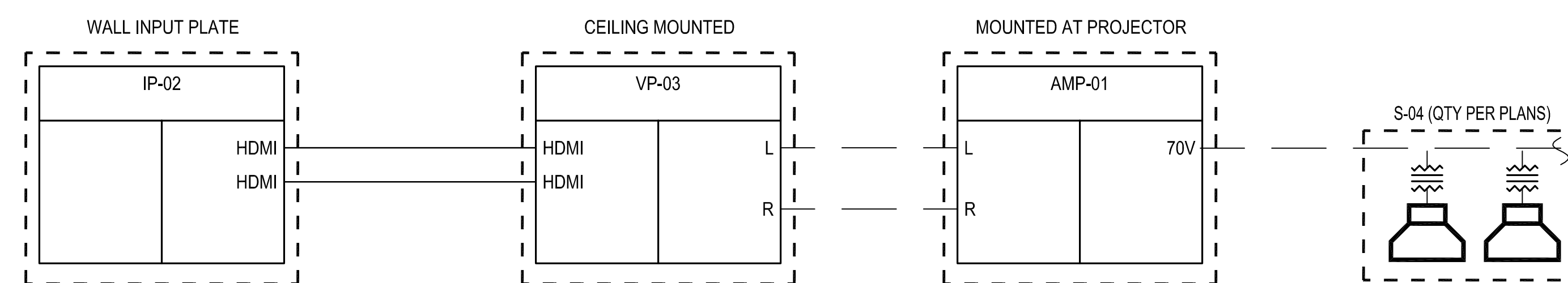

4 AUDIOVISUAL SIGNAL FLOW DIAGRAM - CLASSROOM 5004
SCALE: NTS

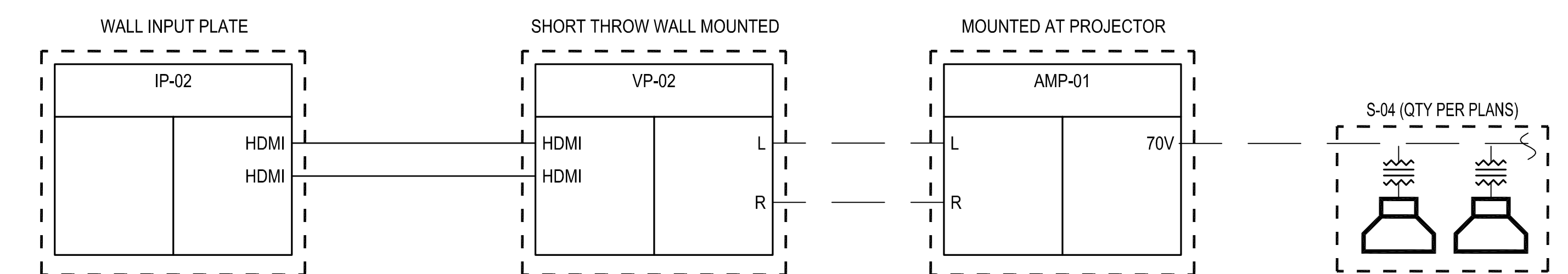

1 AUDIOVISUAL SIGNAL FLOW DIAGRAM - CLASSROOM TYPE 1 (4002,4003, 5002, 5003, 5005,5012, 5013, 5014)
SCALE: NTS

NOTE: CONTRACTOR SHALL VERIFY ALL DIMENSIONS AND CONDITIONS AT JOB SITE AND BE FULLY RESPONSIBLE FOR SAME.

REVISIONS		
NO.	DESCRIPTION	DATE
01	REVISION A	09.16.14
02	REVISION B	09.16.14
03	REVISION C	10.29.14
04	AV 100% DD FINAL REVISION	11.24.15
05	100% CD FOR CONSTRUCTION	03.25.16

DRAWN	PREPARED
TL	RST
TRACED	APPROVED
TL	RST
CHECKED	APPROVED
TL	RST

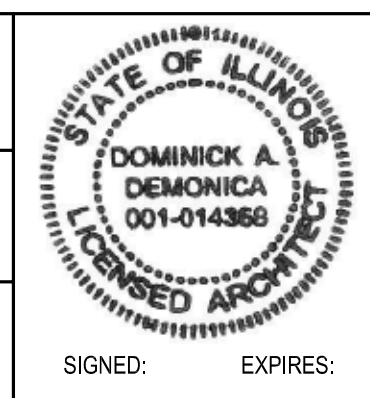

DKA DEMONICA KEMPER ARCHITECTS
125 N. HALSTED STREET, SUITE 301
CHICAGO, IL 60661
P: 312.496.0000

KJWW KJWW ENGINEERING
1100 WARRENVILLE ROAD, #400W
NAPERVILLE, IL 60563
T: 312.559.4585

E.F.W. E.F. WHITNEY, INC.
568 ANN STREET
BIRMINGHAM, MI 48009
T: 248.644.0990

SM&W SHEN MILSOM WILKE LLC
2 N. RIVERSIDE PLAZA
CHICAGO, IL 60606
T: 312.559.4585

100% CD FOR CONSTRUCTION		PROJECT NO.
AUDIOVISUAL SIGNAL FLOW DIAGRAMS		DATE
CITY CENTER CAMPUS JOLIET JUNIOR COLLEGE		APRIL 21, 2016
		SHEET NO.
		TA703

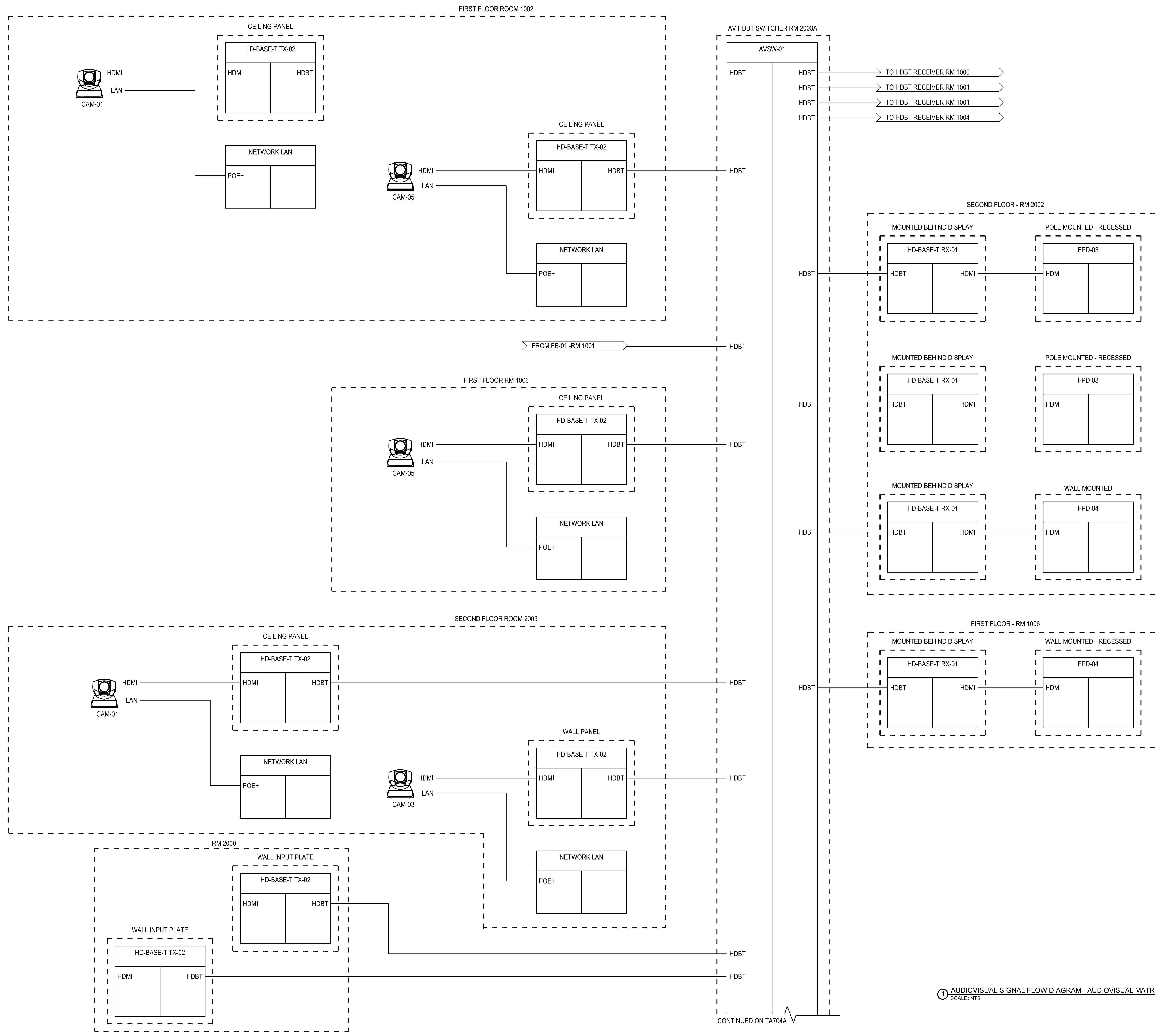

1 AUDIOVISUAL SIGNAL FLOW DIAGRAM - AUDIOVISUAL MATRIX SYSTEM
SCALE: NTS

CONTINUED ON TA704A

NOTE: CONTRACTOR SHALL VERIFY ALL DIMENSIONS AND CONDITIONS AT JOB SITE AND BE FULLY RESPONSIBLE FOR SAME.

REVISIONS		
NO.	DESCRIPTION	DATE
01	REVISION A	09.16.14
02	REVISION B	09.16.14
03	REVISION C	10.29.14
04	AV 100% DD FINAL REVISION	11.24.15
05	100% CD FOR CONSTRUCTION	03.25.16

DRAWN	PREPARED
TL	RST
TRACED	APPROVED
TL	RST
CHECKED	APPROVED
TL	RST

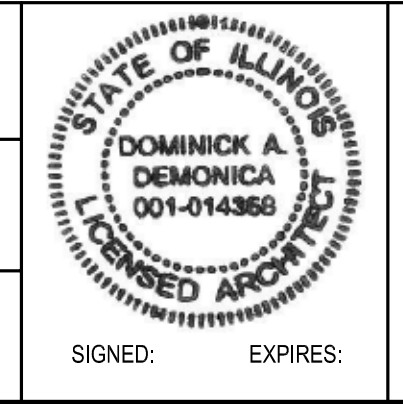

DKA DEMONICK A. DEMONICA ARCHITECTS
125 N. HALSTED STREET, SUITE 301
CHICAGO, IL 60661
P: 312.496.0000

KJW KJWW ENGINEERING
1100 WARRENVILLE ROAD, #400W
NAPERVILLE, IL 60563
T: 312.559.4585

EFW E.F. WHITNEY, INC.
568 ANN STREET
BIRMINGHAM, MI 48009
T: 248.644.0990

SM&W SHEN MILSOM WILKE
2 N. RIVERSIDE PLAZA
CHICAGO, IL 60606
T: 312.559.4585

100% CD FOR CONSTRUCTION		PROJECT NO.
AUDIOVISUAL SIGNAL FLOW DIAGRAMS		DATE
CITY CENTER CAMPUS JOLIET JUNIOR COLLEGE		SHEET NO.
		TA704

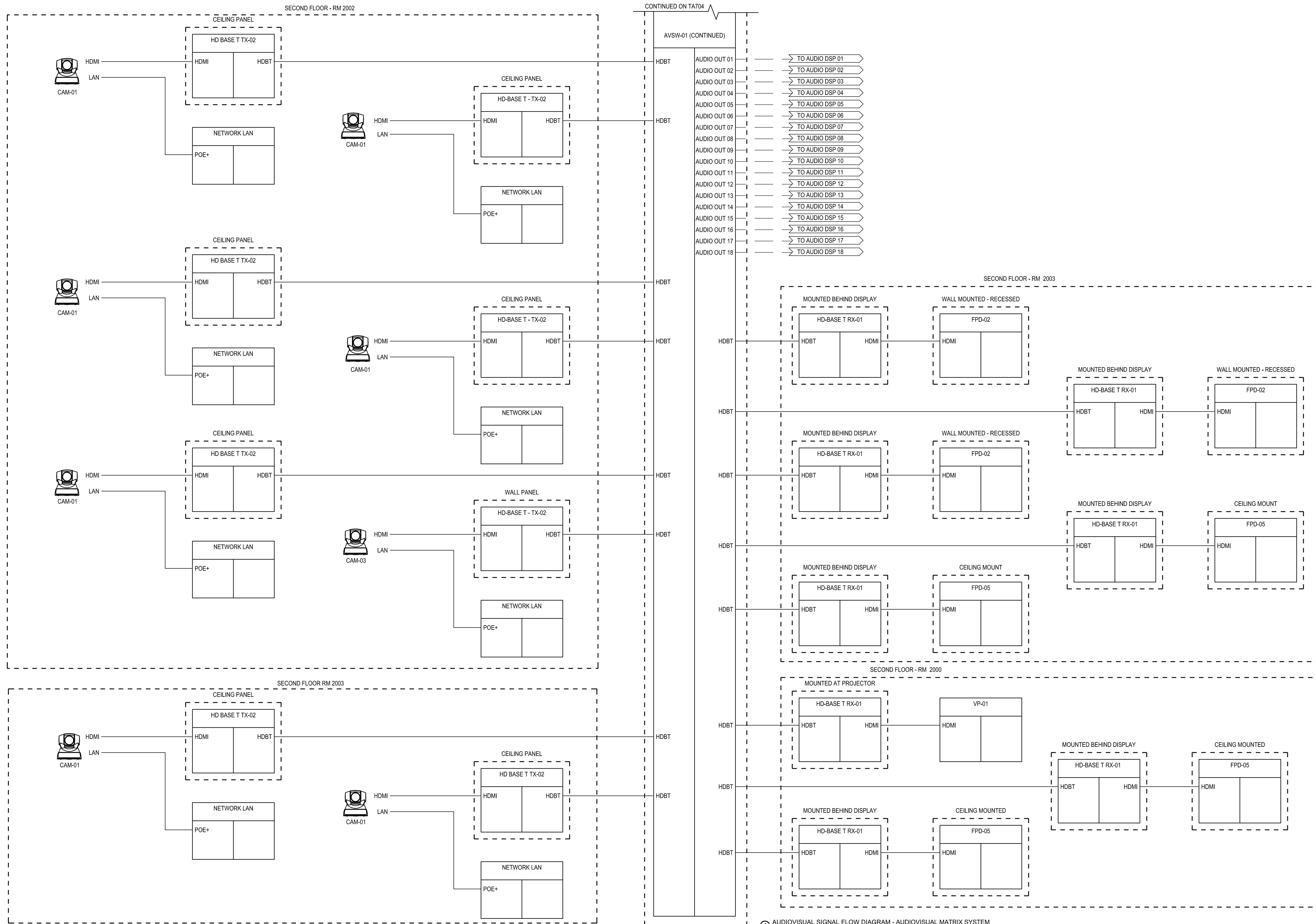

1 AUDIOVISUAL SIGNAL FLOW DIAGRAM - AUDIOVISUAL MATRIX SYSTEM
SCALE: NTS

NOTE: CONTRACTOR SHALL VERIFY ALL DIMENSIONS AND CONDITIONS AT JOB SITE AND BE FULLY RESPONSIBLE FOR SAME.

REVISIONS		
NO.	DESCRIPTION	DATE
01	REVISION A	09.16.14
02	REVISION B	09.16.14
03	REVISION C	10.29.14
04	AV 100% DD FINAL REVISION	11.24.15
05	100% CD FOR CONSTRUCTION	03.25.16

DRAWN	PREPARED
TL	RST
TRACED	APPROVED
TL	RST
CHECKED	APPROVED
TL	RST

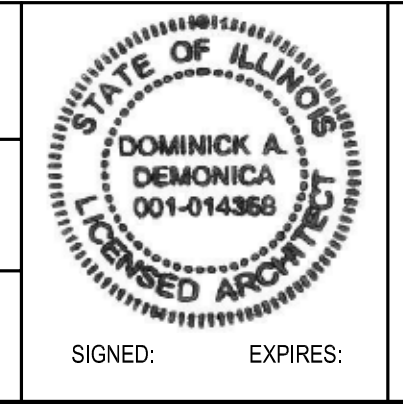

dka DEMONICK A. DEMONICA ARCHITECTS
125 N. HALSTED STREET, SUITE 301
CHICAGO, IL 60661
P: 312.496.0000

KJW KJWW ENGINEERING
1100 WARRENVILLE ROAD, #400W
NAPERVILLE, IL 60563
T: 312.559.4585

EFW E.F. WHITNEY, INC.
568 ANN STREET
BIRMINGHAM, MI 48009
T: 248.644.0990

SM&W SHEN MILSOM WILKE
2 N. RIVERSIDE PLAZA
CHICAGO, IL 60606
T: 312.559.4585

100% CD FOR CONSTRUCTION		PROJECT NO.
AUDIOVISUAL SIGNAL FLOW DIAGRAMS		DATE
CITY CENTER CAMPUS JOLIET JUNIOR COLLEGE		SHEET NO.
		TA704A

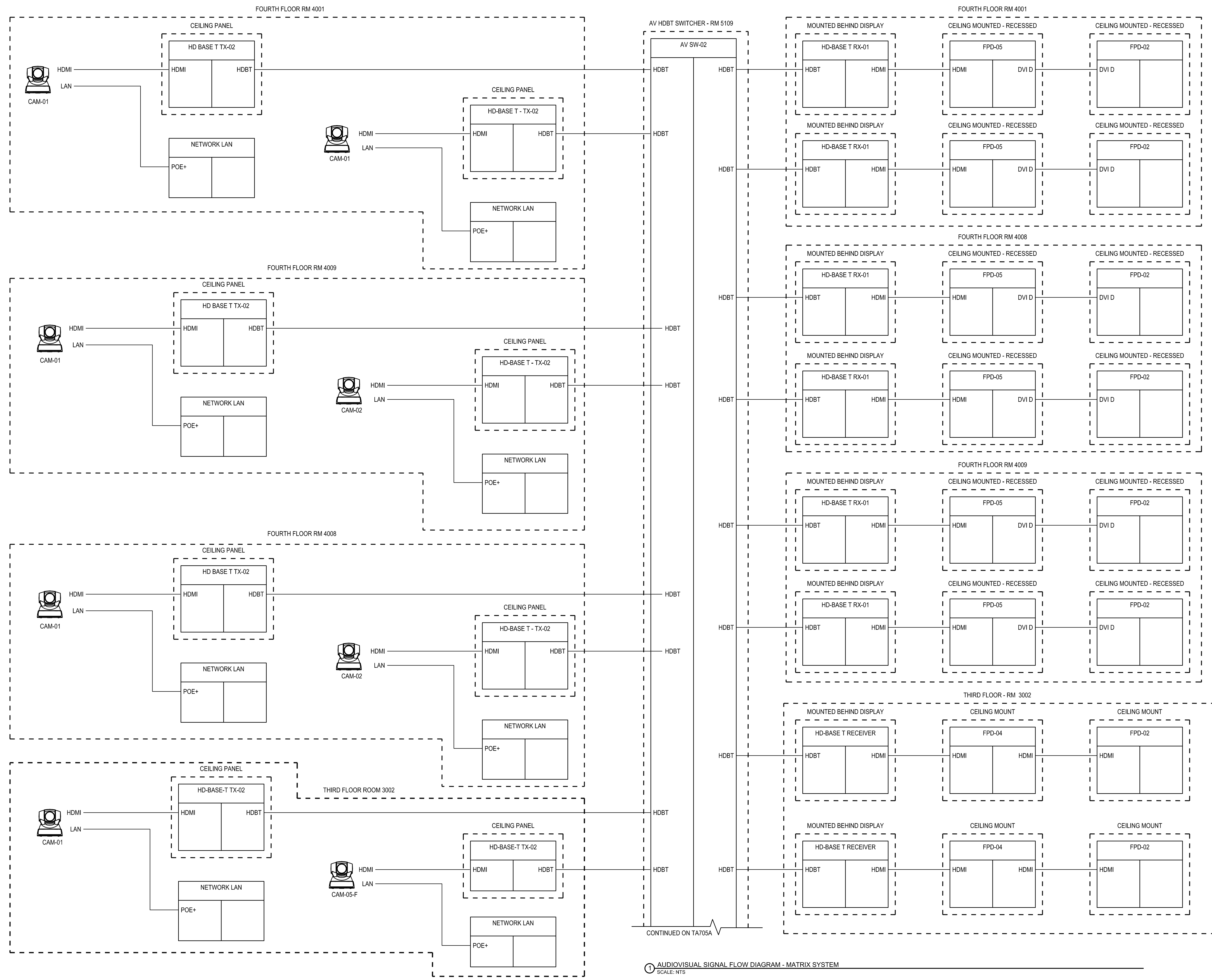

CONTINUED ON TA705A

AUDIOVISUAL SIGNAL FLOW DIAGRAM - MATRIX SYSTEM
SCALE: NTS

NOTE: CONTRACTOR SHALL VERIFY ALL DIMENSIONS AND CONDITIONS AT JOB SITE AND BE FULLY RESPONSIBLE FOR SAME.

REVISIONS		
NO.	DESCRIPTION	DATE
01	REVISION A	09.16.14
02	REVISION B	09.16.14
03	REVISION C	10.29.14
04	AV 100% DD FINAL REVISION	11.24.15
05	100% CD FOR CONSTRUCTION	03.25.16

DRAWN	PREPARED
TL	RST
TRACED	APPROVED
TL	RST
CHECKED	APPROVED
TL	RST

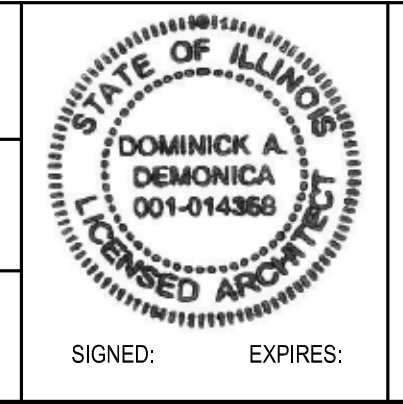

DKA DEMONICA KEMPER ARCHITECTS
125 N. HALSTED STREET, SUITE 301
CHICAGO, IL 60661
P: 312.496.0000

KJWW KJWW ENGINEERING
1100 WARRENVILLE ROAD, #400W
NAPERVILLE, IL 60563
T: 312.559.4585

EFW E.F. WHITNEY, INC.
568 ANN STREET
BIRMINGHAM, MI 48009
T: 248.644.0990

SM&W SHEN MILSON WILKE
2 N. RIVERSIDE PLAZA
CHICAGO, IL 60606
T: 312.559.4585

100% CD FOR CONSTRUCTION		PROJECT NO.
AUDIOVISUAL SIGNAL FLOW DIAGRAMS		DATE
CITY CENTER CAMPUS JOLIET JUNIOR COLLEGE		SHEET NO.
		TA705

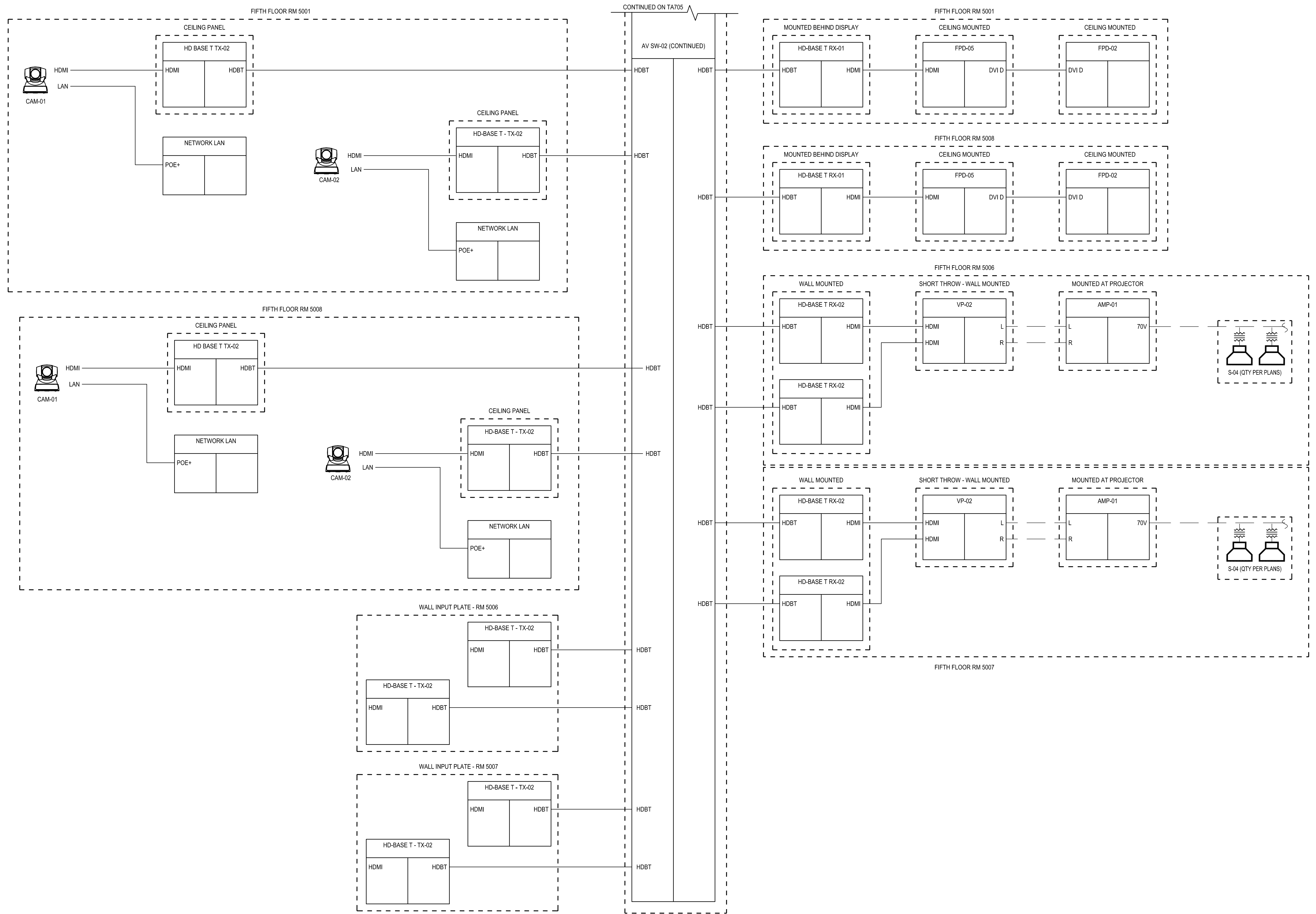

1 AUDIOVISUAL SIGNAL FLOW DIAGRAM - XXX
SCALE: NTS

NOTE: CONTRACTOR SHALL VERIFY ALL DIMENSIONS AND CONDITIONS AT JOB SITE AND BE FULLY RESPONSIBLE FOR SAME.

REVISIONS			DRAWN	PREPARED	100% CD FOR CONSTRUCTION				PROJECT NO.
NO.	DESCRIPTION	DATE	TL	RST	AUDIOVISUAL SIGNAL FLOW DIAGRAMS				PROJECT NO.
01	REVISION A	09.16.14	TL	RST					DATE
02	REVISION B	09.16.14	TL	RST					APRIL 21, 2016
03	REVISION C	10.29.14	TL	RST					SHEET NO.
04	AV 100% DD FINAL REVISION	11.24.15	TL	RST					TA705A
05	100% CD FOR CONSTRUCTION	03.25.16	TL	RST					

 DKA DEMONICA KEMPER ARCHITECTS 125 N. HALSTED STREET, SUITE 301 CHICAGO, IL 60661 P: 312.496.0000	 KJWW ENGINEERING 1100 WARRENVILLE ROAD, #400W NAPERVILLE, IL 60563 T: 312.559.4585	 E.F. WHITNEY, INC. 568 ANN STREET BIRMINGHAM, MI 48009 T: 248.644.0990	 SM&W SHEN MILSON WILKE 2 N. RIVERSIDE PLAZA CHICAGO, IL 60606 T: 312.559.4585
---	--	--	---

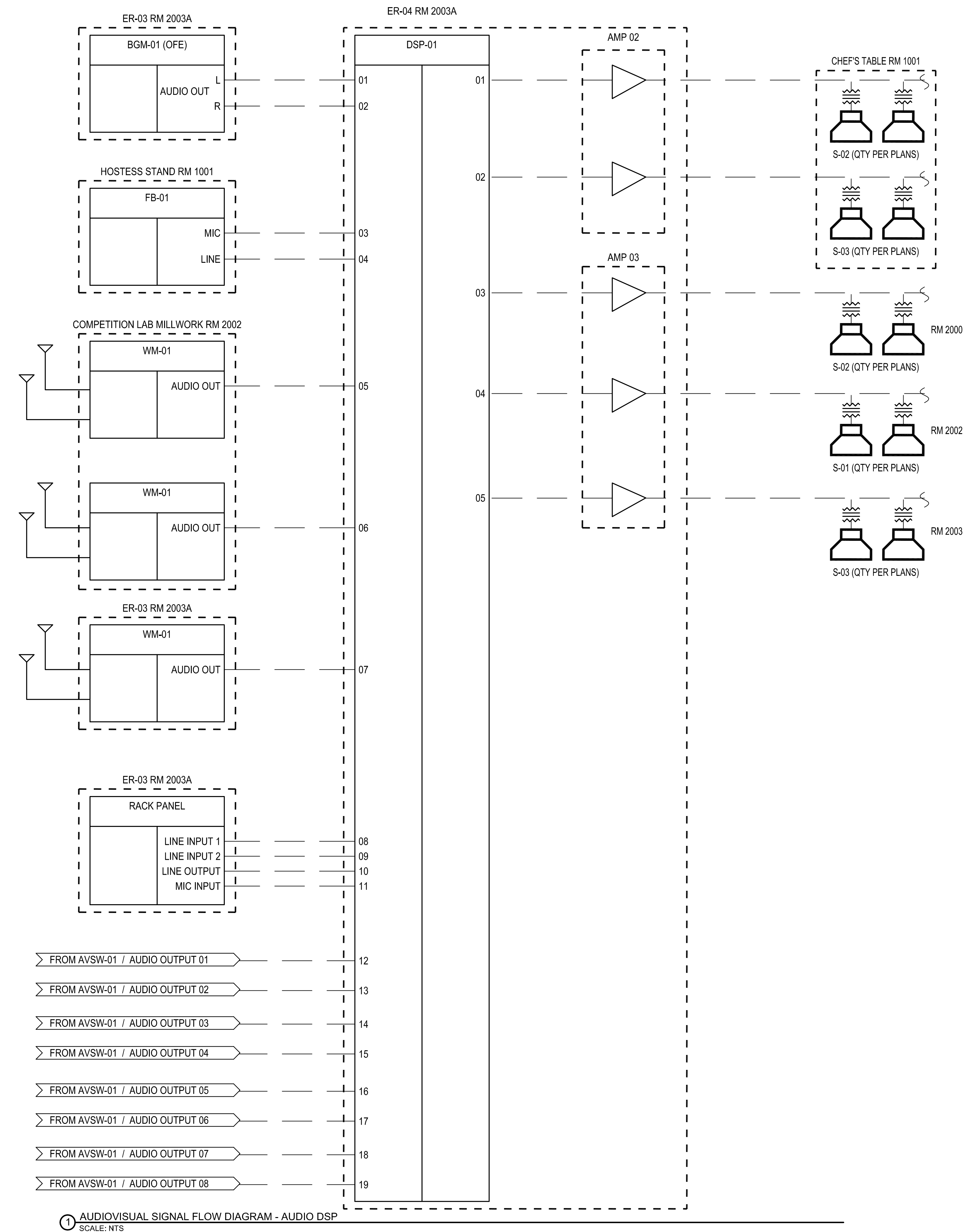

NOTE: CONTRACTOR SHALL VERIFY ALL DIMENSIONS AND CONDITIONS AT JOB SITE AND BE FULLY RESPONSIBLE FOR SAME.

REVISIONS			DRAWN	PREPARED	100% CD FOR CONSTRUCTION				PROJECT NO.	
NO.	DESCRIPTION	DATE	TL	RST	AUDIOVISUAL SIGNAL FLOW DIAGRAMS				PROJECT NO.	
01	REVISION A	09.16.14	TRACED	APPROVED	CITY CENTER CAMPUS JOLIET JUNIOR COLLEGE				DATE	
02	REVISION B	09.16.14	TL	RST					APRIL 21, 2016	
03	REVISION C	10.29.14	CHECKED	APPROVED					SHEET NO.	
04	AV 100% DD FINAL REVISION	11.24.15	TL	RST					TA706	
05	100% CD FOR CONSTRUCTION	03.25.16								
125 N. HALSTED STREET, SUITE 301 CHICAGO, IL 60661 P: 312.496.0000			1100 WARRENVILLE ROAD, #400W NAPERVILLE, IL 60563 T: 312.559.4585		568 ANN STREET BIRMINGHAM, MI 48009 T: 248.644.0990		2 N. RIVERSIDE PLAZA CHICAGO, IL 60606 T: 312.559.4585			

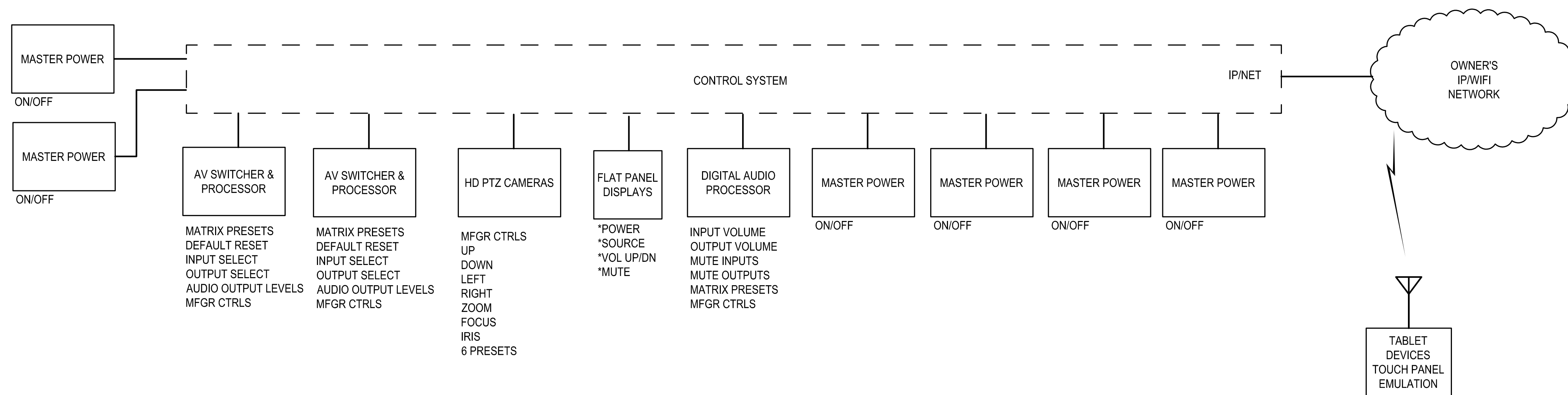

1 AUDIOVISUAL CONTROL DIAGRAM
NTS

NOTE: CONTRACTOR SHALL VERIFY ALL DIMENSIONS AND CONDITIONS AT JOB SITE AND BE FULLY RESPONSIBLE FOR SAME.

REVISIONS			DRAWN	PREPARED	100% CD FOR CONSTRUCTION				PROJECT NO.
NO.	DESCRIPTION	DATE	TL	RST	AUDIOVISUAL SIGNAL FLOW DIAGRAMS				
01	REVISION A	09.16.14	TRACED	APPROVED					DATE
02	REVISION B	09.16.14	TL	RST					APRIL 21, 2016
03	REVISION C	10.29.14							SHEET NO.
04	AV 100% DD FINAL REVISION	11.24.15							CITY CENTER CAMPUS
05	100% CD FOR CONSTRUCTION	03.25.16	CHECKED	APPROVED					JOLIET JUNIOR COLLEGE
			TL	RST					TA707

 DOMINICK A. DEMONICK 001-014360 REGISTERED ARCHITECT	DEMONICK KEMPER ARCHITECTS 125 N. HALSTED STREET, SUITE 301 CHICAGO, IL 60661 P: 312.496.0000	KJW ENGINEERING 1100 WARRENVILLE ROAD, #400W NAPERVILLE, IL 60563 T: 312.559.4585	E.F. WHITNEY, INC. 568 ANN STREET BIRMINGHAM, MI 48009 T: 248.644.0990	SHEN MILSOM WILKE LLC 2 N. RIVERSIDE PLAZA CHICAGO, IL 60606 T: 312.559.4585
--	--	--	---	---

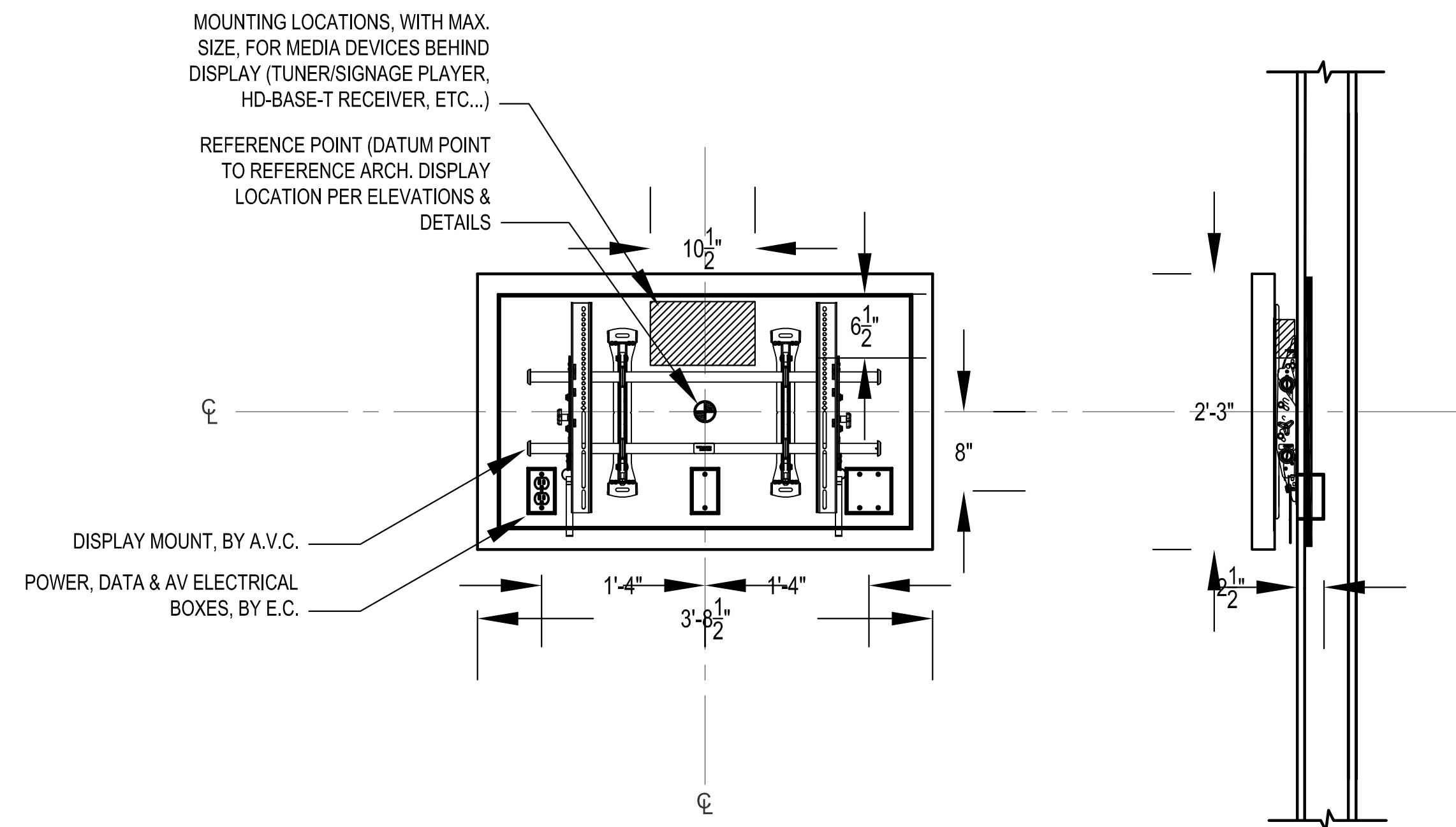

NOTES:

1. THE DIMENSIONING, AS SHOWN, REPRESENTS THE BLOCKING AND BACK BOX POSITIONING REQUIREMENTS FOR A GENERAL CROSS-SECTION OF MANUFACTURERS AND PRODUCTS FOR THIS SIZE FLAT PANEL DISPLAY. DIMENSIONS, AS SHOWN, WILL ACCOMMODATE MOST DISPLAYS CURRENT TO THE MARKET PLACE, BUT MAY NOT REFLECT ALL FUTURE DISPLAYS OR MANUFACTURERS.
2. GENERAL CONTRACTOR TO PROVIDE NECESSARY BLOCKING TO SUPPORT FLAT PANEL DISPLAY. WEIGHT: APPROX. 75LBS. BACKING DIMENSIONS GIVEN TO SPAN MULTIPLE STUDS IN WALL.
3. AV CONTRACTOR TO VERIFY IF DISPLAY IS TO BE VERTICALLY CENTERED TO SCREEN OR CHASSIS.
4. ALL BOXES, CONDUIT AND POWER BY EC. DATA CONNECTORS, PLATE AND CABLE BY LOW VOLTAGE CABLE PROVIDER OR AS WITHIN WRITTEN SPECIFICATIONS.
5. COORDINATE REFERENCE POINT LOCATIONS WITH ARCHITECTURAL DRAWINGS.

3 AUDIOVISUAL DETAIL - 40" FLAT PANEL DISPLAY - SURFACE MOUNTED
NTS

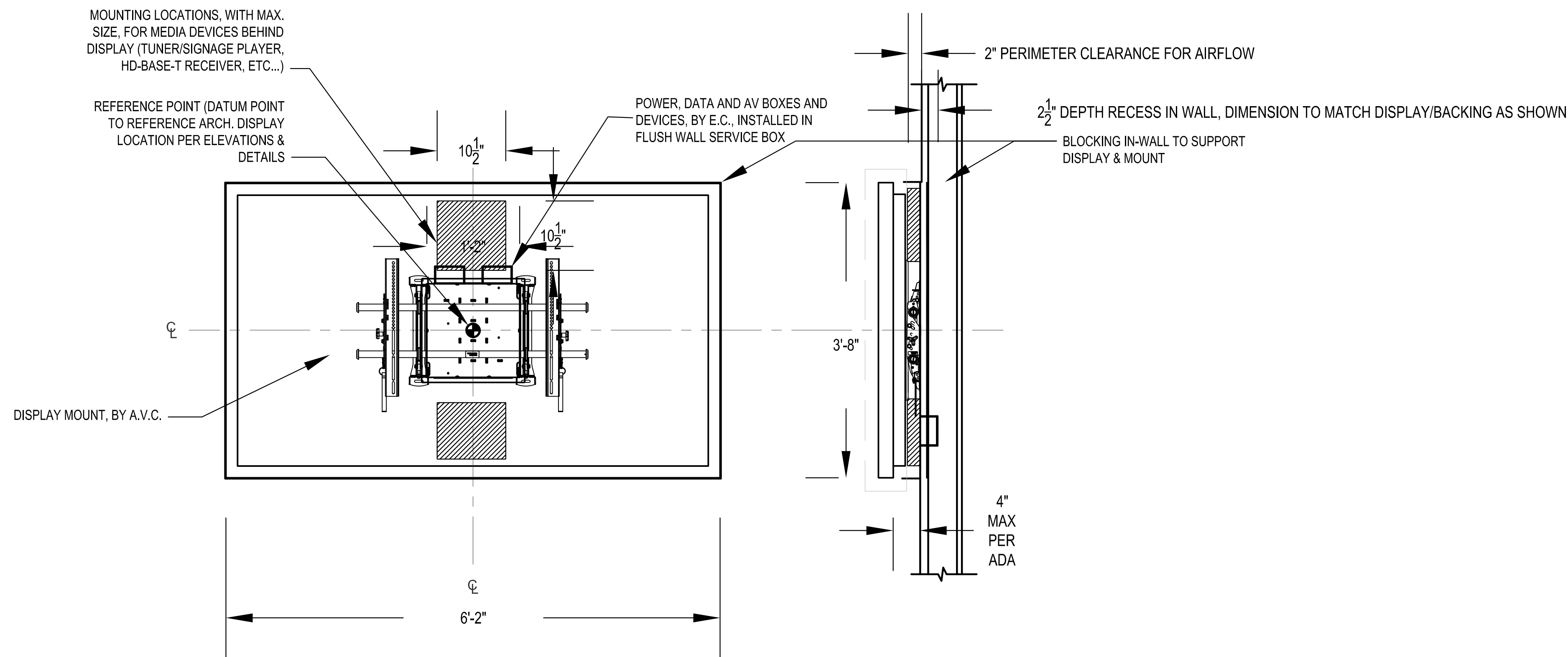

NOTES:

1. THE DIMENSIONING, AS SHOWN, REPRESENTS THE BLOCKING AND BACK BOX POSITIONING REQUIREMENTS FOR A GENERAL CROSS-SECTION OF MANUFACTURERS AND PRODUCTS FOR THIS SIZE FLAT PANEL DISPLAY. DIMENSIONS, AS SHOWN, WILL ACCOMMODATE MOST DISPLAYS CURRENT TO THE MARKET PLACE, BUT MAY NOT REFLECT ALL FUTURE DISPLAYS OR MANUFACTURERS.
2. GENERAL CONTRACTOR TO PROVIDE NECESSARY BLOCKING TO SUPPORT FLAT PANEL DISPLAY. WEIGHT: APPROX. 250LBS. BACKING DIMENSIONS GIVEN TO SPAN MULTIPLE STUDS IN WALL.
3. AV CONTRACTOR TO VERIFY IF DISPLAY IS TO BE VERTICALLY CENTERED TO SCREEN OR CHASSIS.
4. ALL BOXES, CONDUIT AND POWER BY EC. DATA CONNECTORS, PLATE AND CABLE BY LOW VOLTAGE CABLE PROVIDER OR AS WITHIN WRITTEN SPECIFICATIONS.
5. COORDINATE REFERENCE POINT LOCATIONS WITH ARCHITECTURAL DRAWINGS.

4 AUDIOVISUAL DETAIL - 80" FLAT PANEL DISPLAY - SURFACE MOUNTED
NTS

NOTE: CONTRACTOR SHALL VERIFY ALL DIMENSIONS AND CONDITIONS AT JOB SITE AND BE FULLY RESPONSIBLE FOR SAME.

REVISIONS		
NO.	DESCRIPTION	DATE
01	REVISION A	09.16.14
02	REVISION B	09.16.14
03	REVISION C	10.29.14
04	AV 100% DD FINAL REVISION	11.24.15
05	100% CD FOR CONSTRUCTION	03.25.16

DRAWN	PREPARED
TL	RST
TRACED	APPROVED
TL	RST
CHECKED	APPROVED
TL	RST

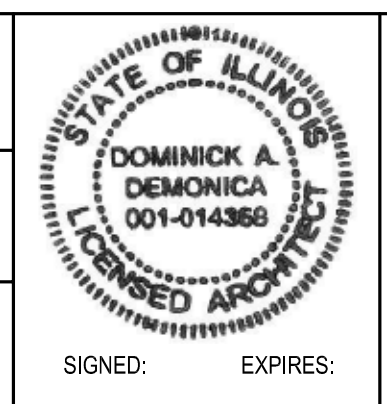

DKA DEMONICA KEMPER ARCHITECTS
125 N. HALSTED STREET, SUITE 301
CHICAGO, IL 60661
P: 312.496.0000

KJW KJWW ENGINEERING
1100 WARRENVILLE ROAD, #400W
NAPERVILLE, IL 60563
T: 312.559.4585

EFW E.F. WHITNEY, INC.
568 ANN STREET
BIRMINGHAM, MI 48009
T: 248.644.0990

SM&W SHEN MILSOM WILKE
2 N. RIVERSIDE PLAZA
CHICAGO, IL 60606
T: 312.559.4585

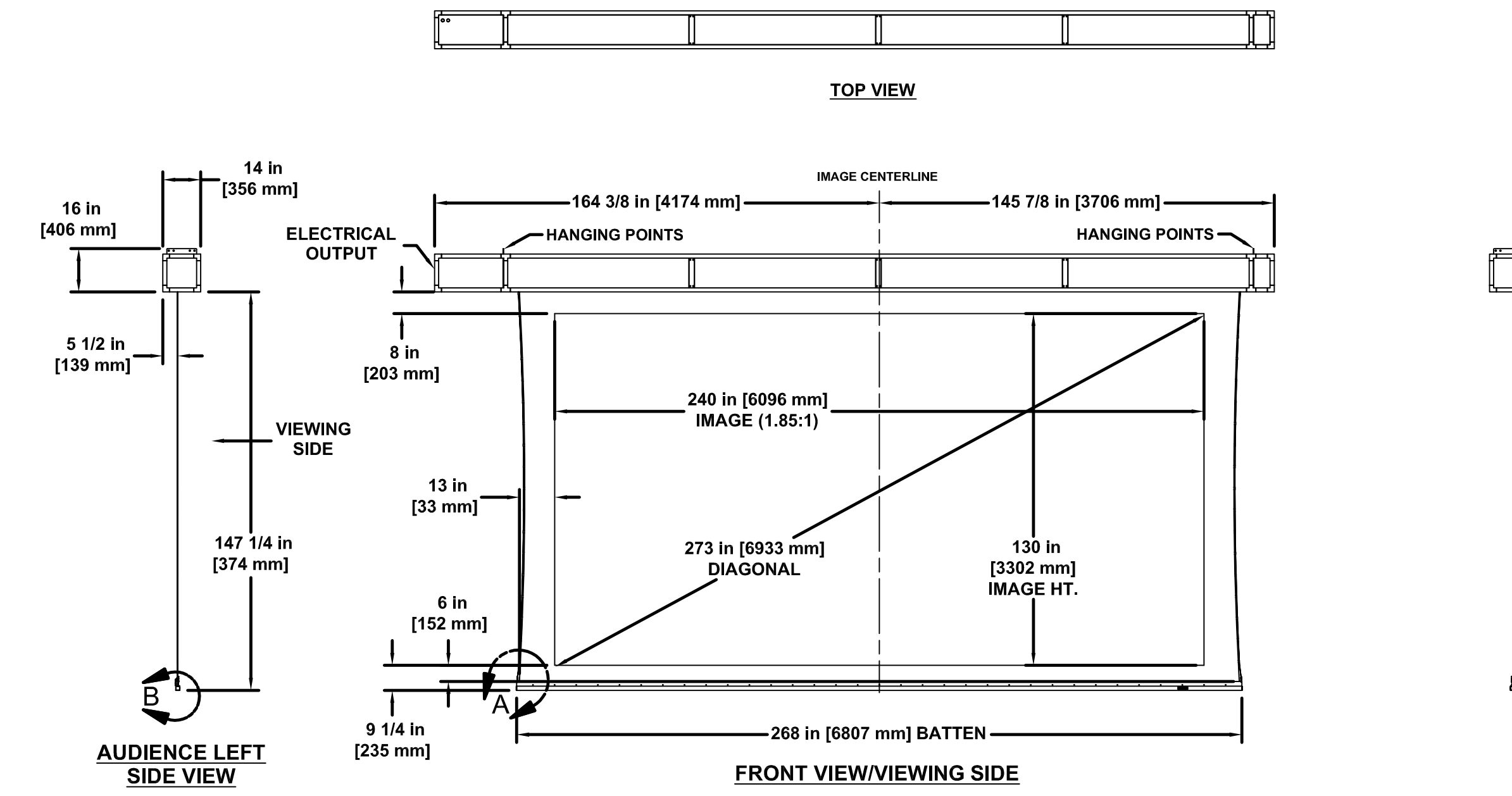

3 PROJECTION SCREEN DETAIL
SCALE: NTS

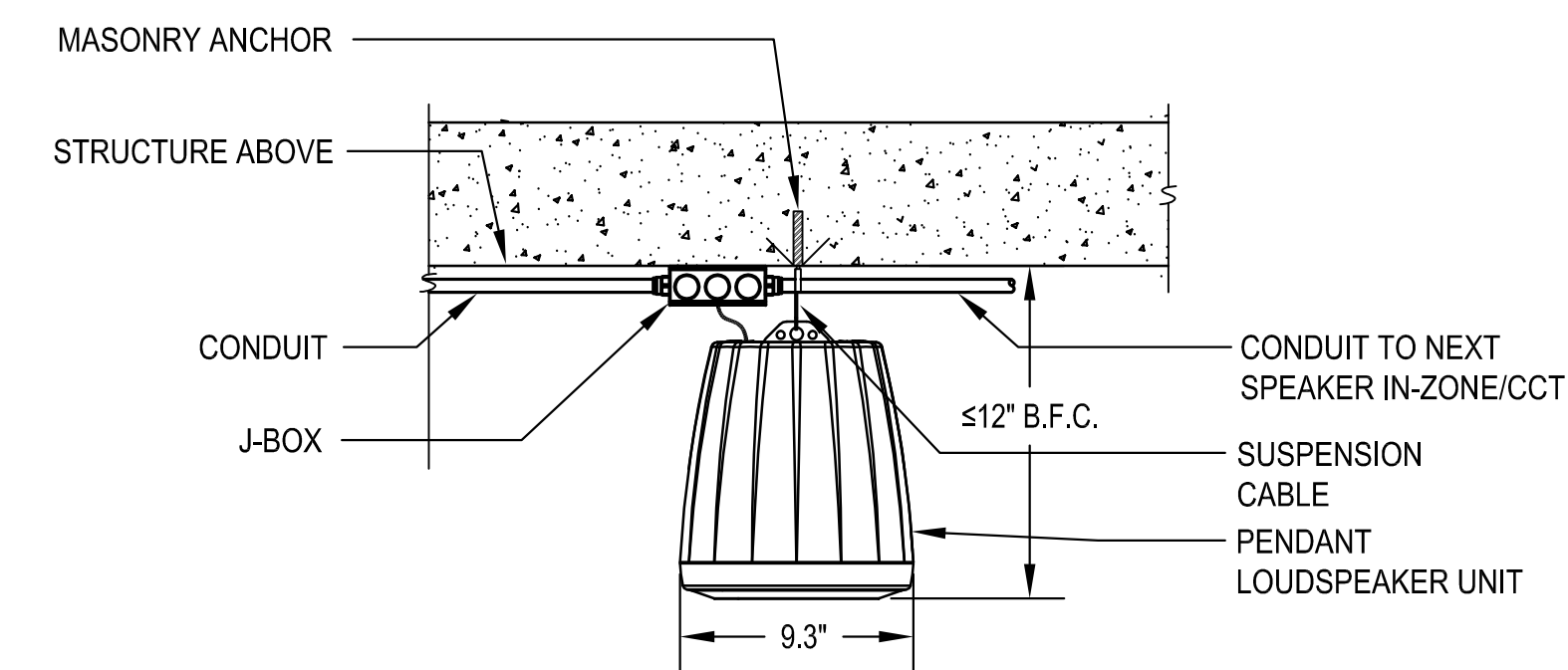

2 AUDIOVISUAL DETAIL - PENDANT SPEAKER
SCALE: NTS

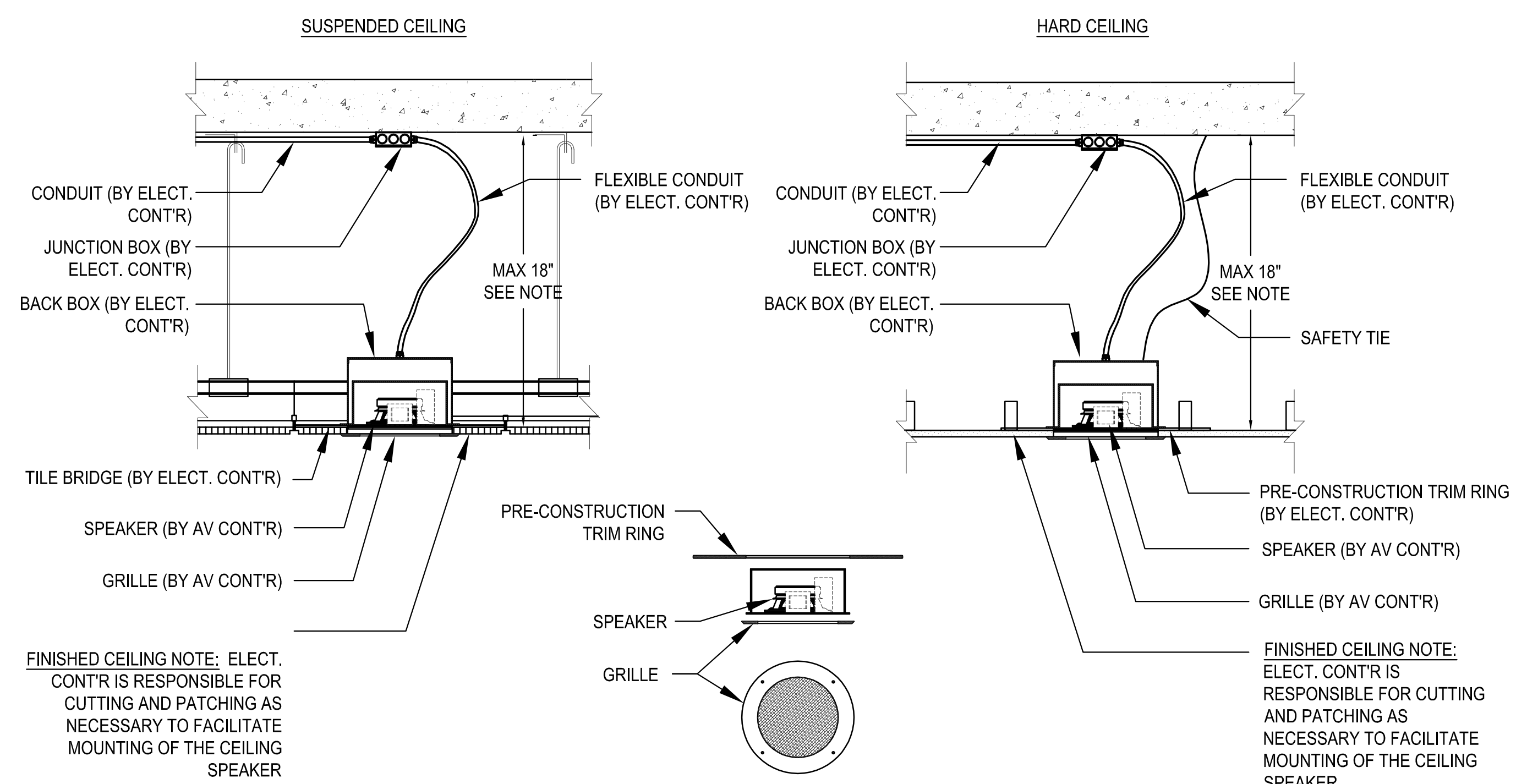

NOTE:
SUPPORT JUNCTION BOX PER APPLICABLE CODES TO MAINTAIN MAX DISTANCE

1 AUDIOVISUAL DETAIL - CEILING SPEAKER
SCALE: NTS

100% CD FOR CONSTRUCTION
AUDIOVISUAL DETAILS

CITY CENTER CAMPUS
JOLIET JUNIOR COLLEGE

PROJECT NO.

DATE
APRIL 21, 2016

SHEET NO.

TA800

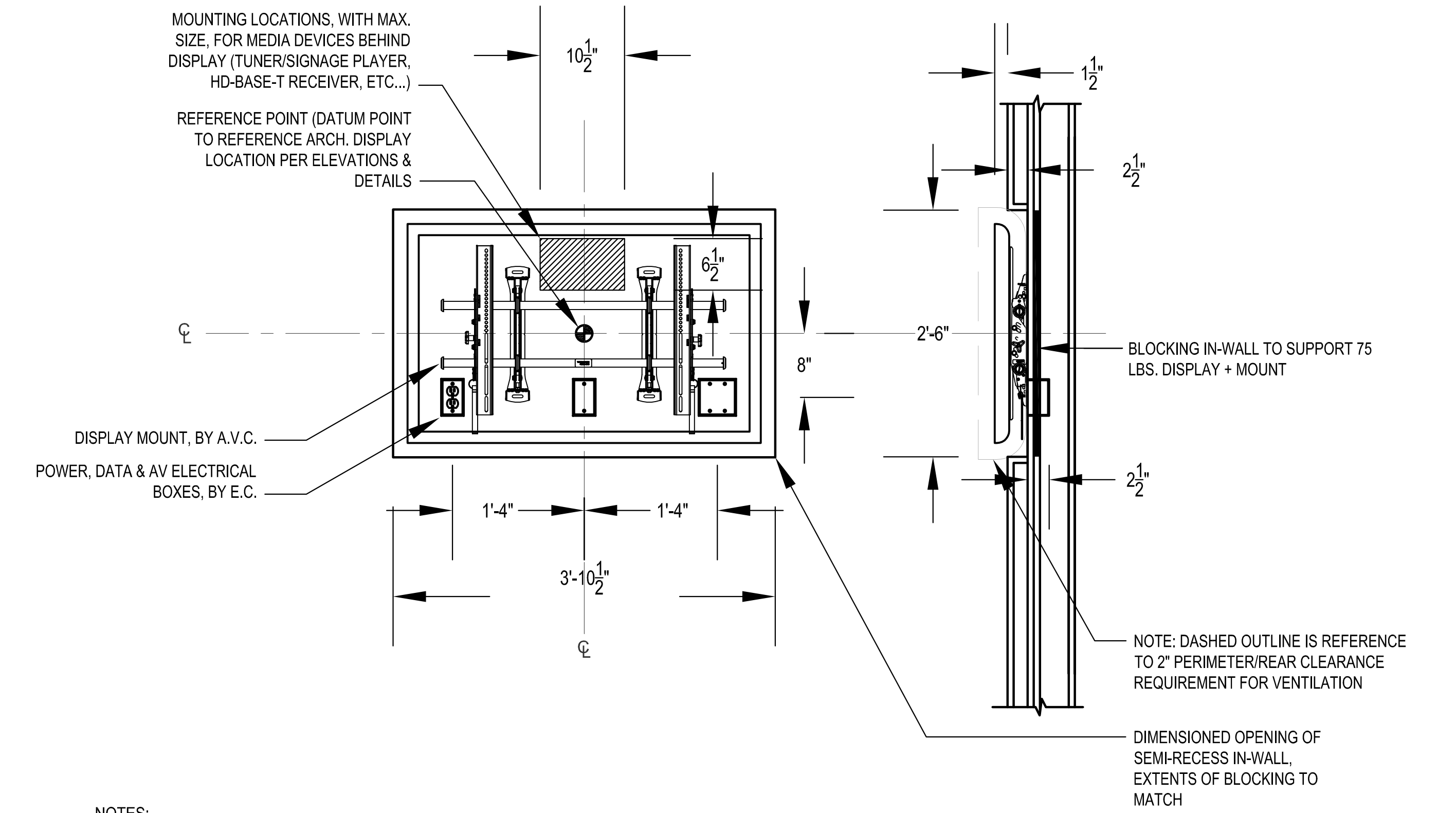
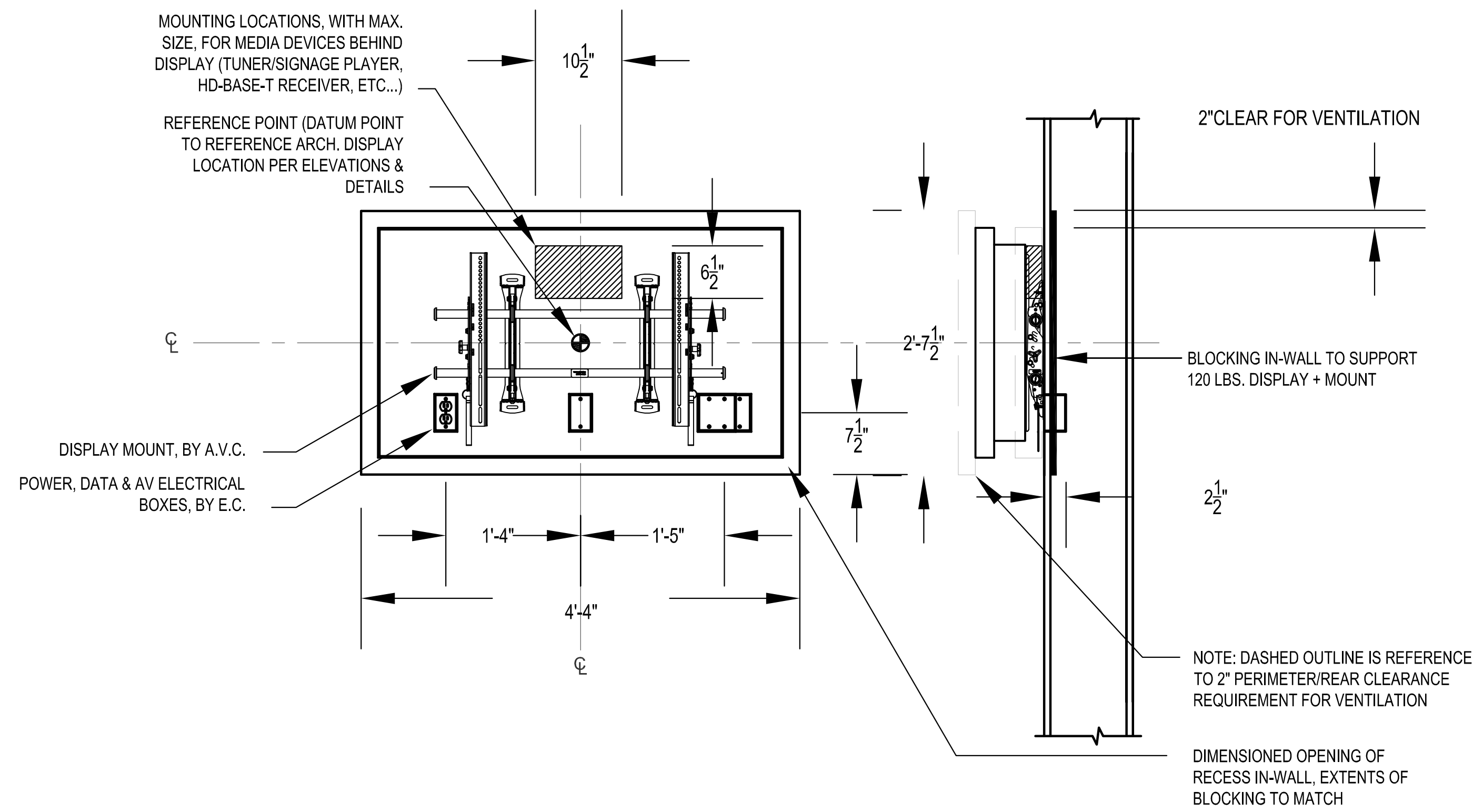

- NOTES:
1. THE DIMENSIONING, AS SHOWN, REPRESENTS THE BLOCKING AND BACK BOX POSITIONING REQUIREMENTS FOR A GENERAL CROSS-SECTION OF MANUFACTURERS AND PRODUCTS FOR THIS SIZE FLAT PANEL DISPLAY. DIMENSIONS, AS SHOWN, WILL ACCOMMODATE MOST DISPLAYS CURRENT TO THE MARKET PLACE, BUT MAY NOT REFLECT ALL FUTURE DISPLAYS OR MANUFACTURERS.
 2. GENERAL CONTRACTOR TO PROVIDE NECESSARY BLOCKING TO SUPPORT FLAT PANEL DISPLAY. WEIGHT: APPROX. 75LBS. BACKING DIMENSIONS GIVEN TO SPAN MULTIPLE STUDS IN WALL.
 3. AV CONTRACTOR TO VERIFY IF DISPLAY IS TO BE VERTICALLY CENTERED TO SCREEN OR CHASSIS.
 4. ALL BOXES, CONDUIT AND POWER BY EC. DATA CONNECTORS, PLATE AND CABLE BY LOW VOLTAGE CABLE PROVIDER OR AS WITHIN WRITTEN SPECIFICATIONS.
 5. COORDINATE REFERENCE POINT LOCATIONS WITH ARCHITECTURAL DRAWINGS.

4 AUDIOVISUAL DETAIL - 55" FLAT PANEL DISPLAY - FULLY-RECESSED MOUNTED
SCALE: NTS

2 AUDIOVISUAL DETAIL - 47" FLAT PANEL DISPLAY - SEMI-RECESSED MOUNTED
SCALE: NTS

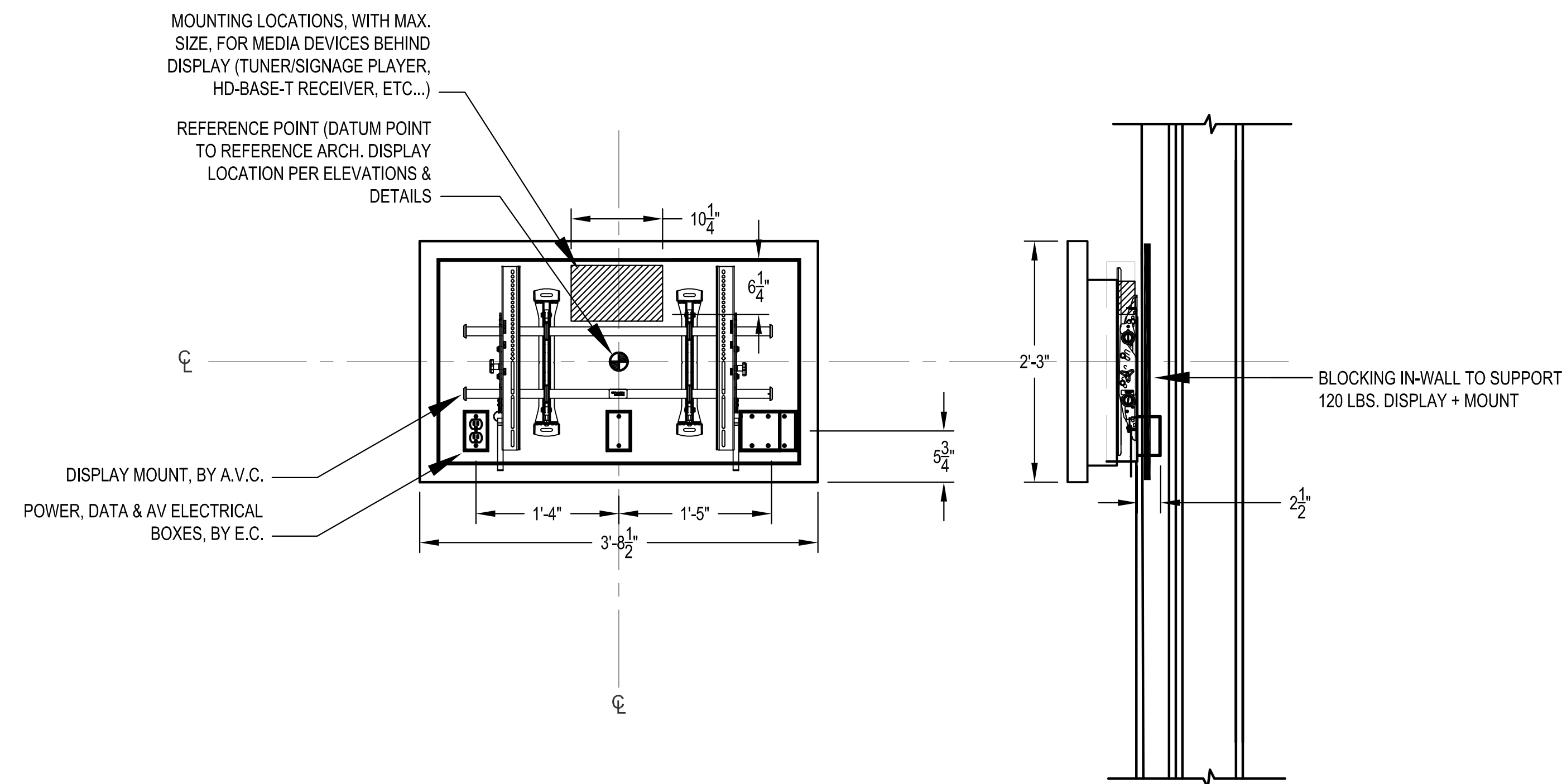

WIDTH 28-27/64" HEIGHT 18-1/2" DEPTH 2-31/64"

- NOTES:
1. THE DIMENSIONING, AS SHOWN, REPRESENTS THE BLOCKING AND BACK BOX POSITIONING REQUIREMENTS FOR A GENERAL CROSS-SECTION OF MANUFACTURERS AND PRODUCTS FOR THIS SIZE FLAT PANEL DISPLAY. DIMENSIONS, AS SHOWN, WILL ACCOMMODATE MOST DISPLAYS CURRENT TO THE MARKET PLACE, BUT MAY NOT REFLECT ALL FUTURE DISPLAYS OR MANUFACTURERS.
 2. GENERAL CONTRACTOR TO PROVIDE NECESSARY BLOCKING TO SUPPORT FLAT PANEL DISPLAY. WEIGHT: APPROX. 75LBS. BACKING DIMENSIONS GIVEN TO SPAN MULTIPLE STUDS IN WALL.
 3. AV CONTRACTOR TO VERIFY IF DISPLAY IS TO BE VERTICALLY CENTERED TO SCREEN OR CHASSIS.
 4. ALL BOXES, CONDUIT AND POWER BY EC. DATA CONNECTORS, PLATE AND CABLE BY LOW VOLTAGE CABLE PROVIDER OR AS WITHIN WRITTEN SPECIFICATIONS.
 5. COORDINATE REFERENCE POINT LOCATIONS WITH ARCHITECTURAL DRAWINGS.

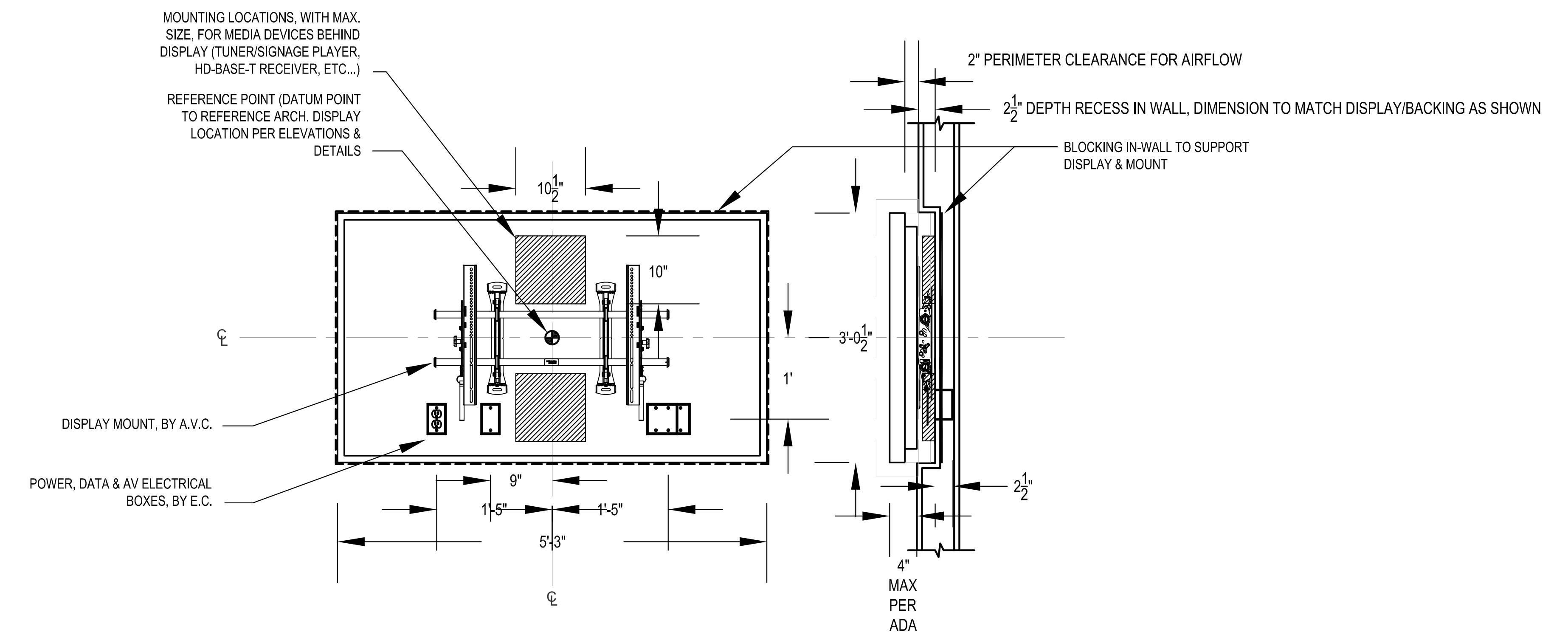

- NOTES:
1. THE DIMENSIONING, AS SHOWN, REPRESENTS THE BLOCKING AND BACK BOX POSITIONING REQUIREMENTS FOR A GENERAL CROSS-SECTION OF MANUFACTURERS AND PRODUCTS FOR THIS SIZE FLAT PANEL DISPLAY. DIMENSIONS, AS SHOWN, WILL ACCOMMODATE MOST DISPLAYS CURRENT TO THE MARKET PLACE, BUT MAY NOT REFLECT ALL FUTURE DISPLAYS OR MANUFACTURERS.
 2. GENERAL CONTRACTOR TO PROVIDE NECESSARY BLOCKING TO SUPPORT FLAT PANEL DISPLAY. WEIGHT: APPROX. 130LBS. BACKING DIMENSIONS GIVEN TO SPAN MULTIPLE STUDS IN WALL.
 3. AV CONTRACTOR TO VERIFY IF DISPLAY IS TO BE VERTICALLY CENTERED TO SCREEN OR CHASSIS.
 4. ALL BOXES, CONDUIT AND POWER BY EC. DATA CONNECTORS, PLATE AND CABLE BY LOW VOLTAGE CABLE PROVIDER OR AS WITHIN WRITTEN SPECIFICATIONS.
 5. COORDINATE REFERENCE POINT LOCATIONS WITH ARCHITECTURAL DRAWINGS.

3 AUDIOVISUAL FLAT PANEL DETAIL - 46" SURFACE MOUNTED
NTS

1 AUDIOVISUAL DETAIL - 70" FLAT PANEL DISPLAY - SEMI-RECESSED MOUNTED
SCALE: NTS

NOTE: CONTRACTOR SHALL VERIFY ALL DIMENSIONS AND CONDITIONS AT JOB SITE AND BE FULLY RESPONSIBLE FOR SAME.

REVISIONS			DRAWN	PREPARED	100% CD FOR CONSTRUCTION				PROJECT NO.
NO.	DESCRIPTION	DATE	TL	RST	AUDIOVISUAL DETAILS				DATE
01	REVISION A	09.16.14	TRACED	APPROVED	CITY CENTER CAMPUS				APRIL 21, 2016
02	REVISION B	09.16.14	TL	RST	JOLIET JUNIOR COLLEGE				SHEET NO.
03	REVISION C	10.29.14	CHECKED	APPROVED					TA801
04	AV 100% DD FINAL REVISION	11.24.15	TL	RST					
05	100% CD FOR CONSTRUCTION	03.25.16							

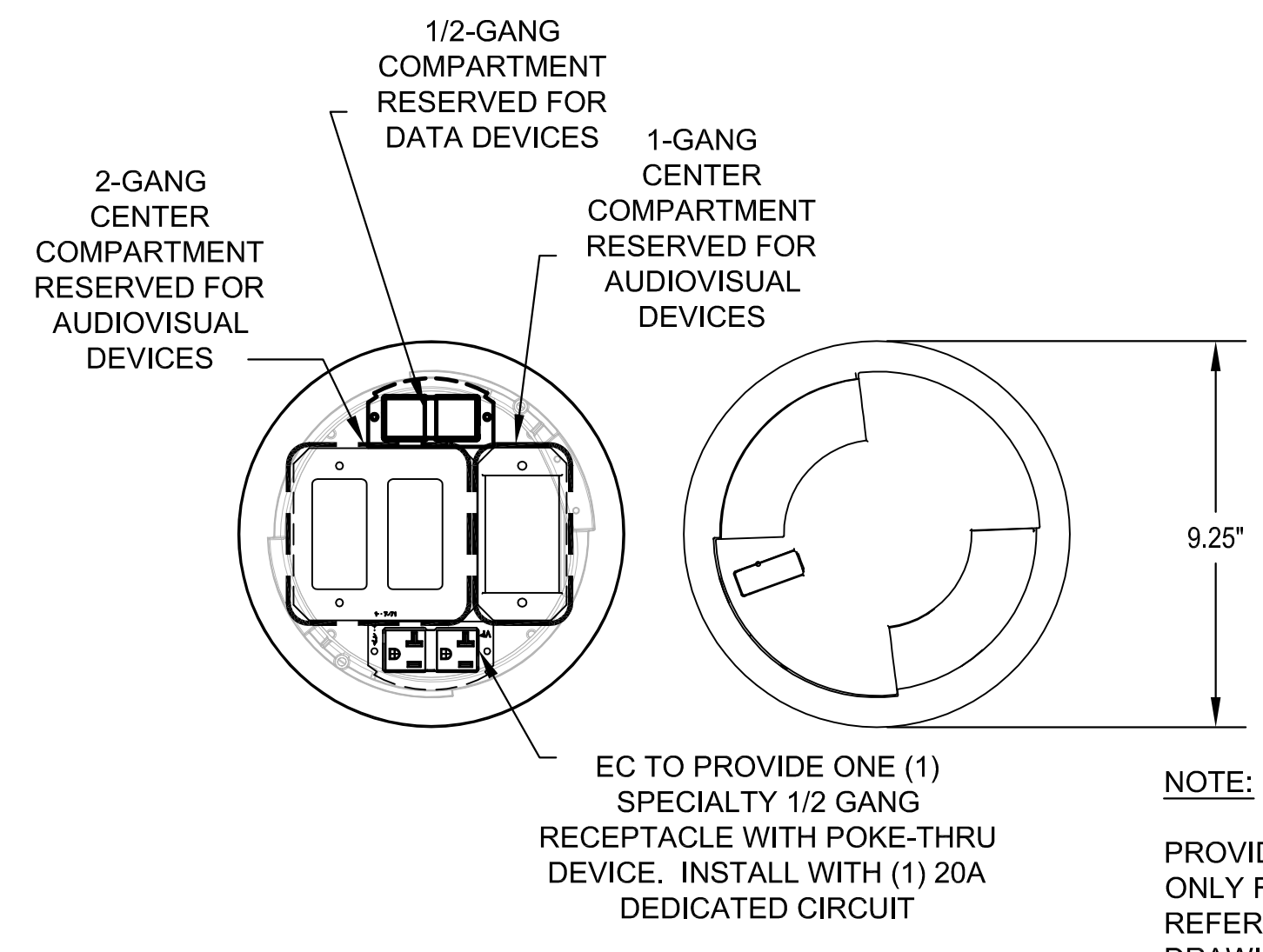

EC TO PROVIDE ONE (1) SPECIALTY 1/2 GANG RECEPTACLE WITH POKE-THRU DEVICE. INSTALL WITH (1) 20A DEDICATED CIRCUIT

NOTE:
PROVIDED FOR REFERENCE ONLY FOR COORDINATION. REFER TO ELECTRICAL DRAWINGS FOR FINAL DEVICE TYPE, LOCATION AND CIRCUITING LAYOUT

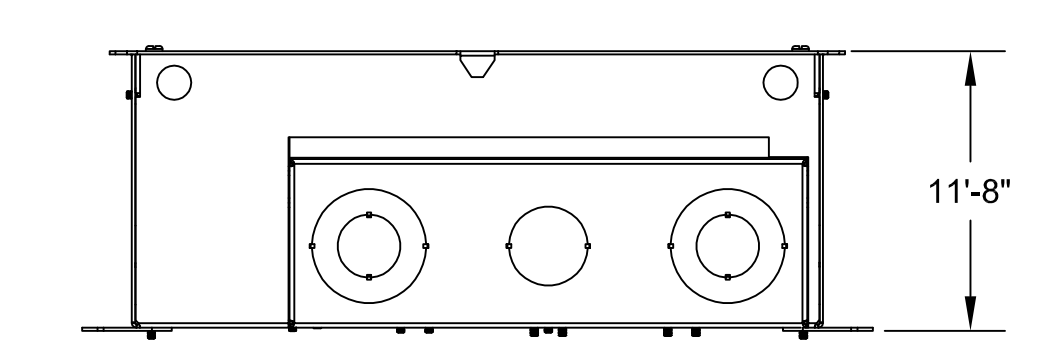
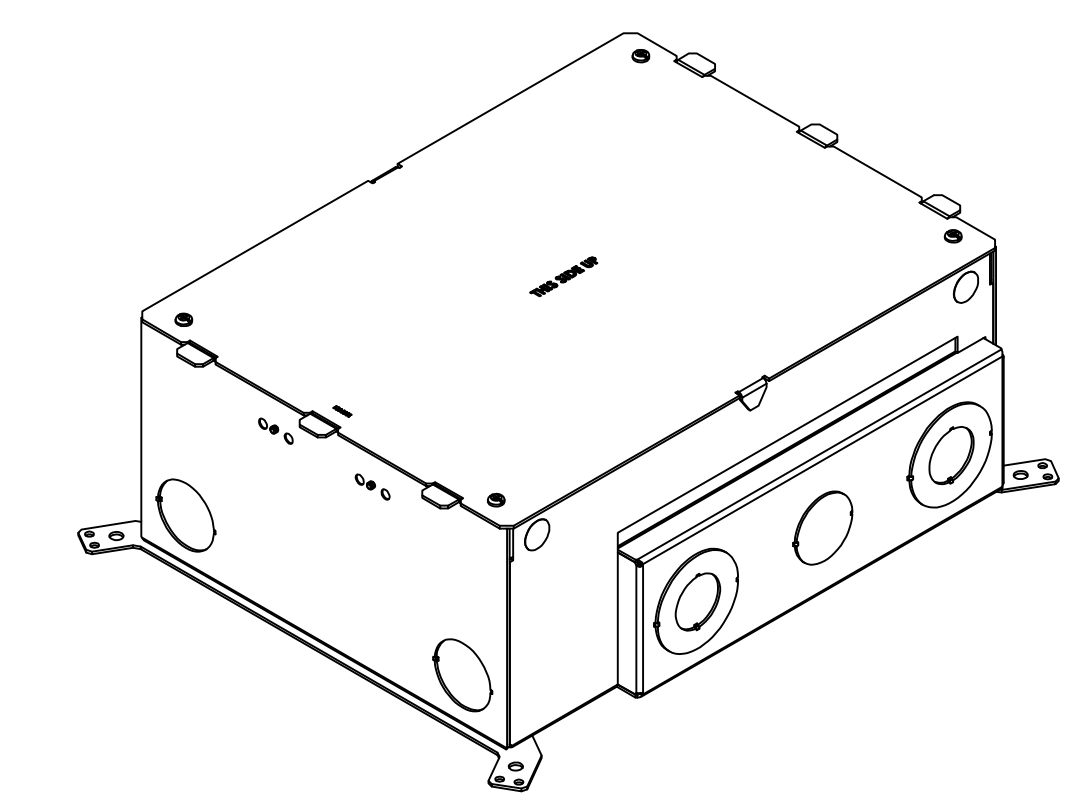
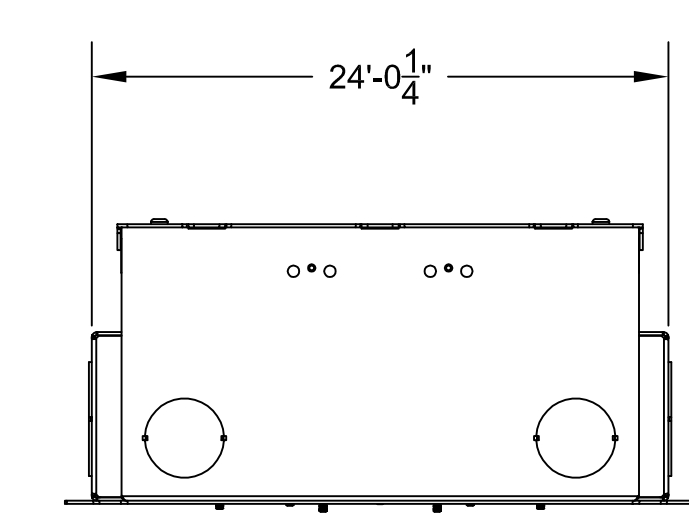
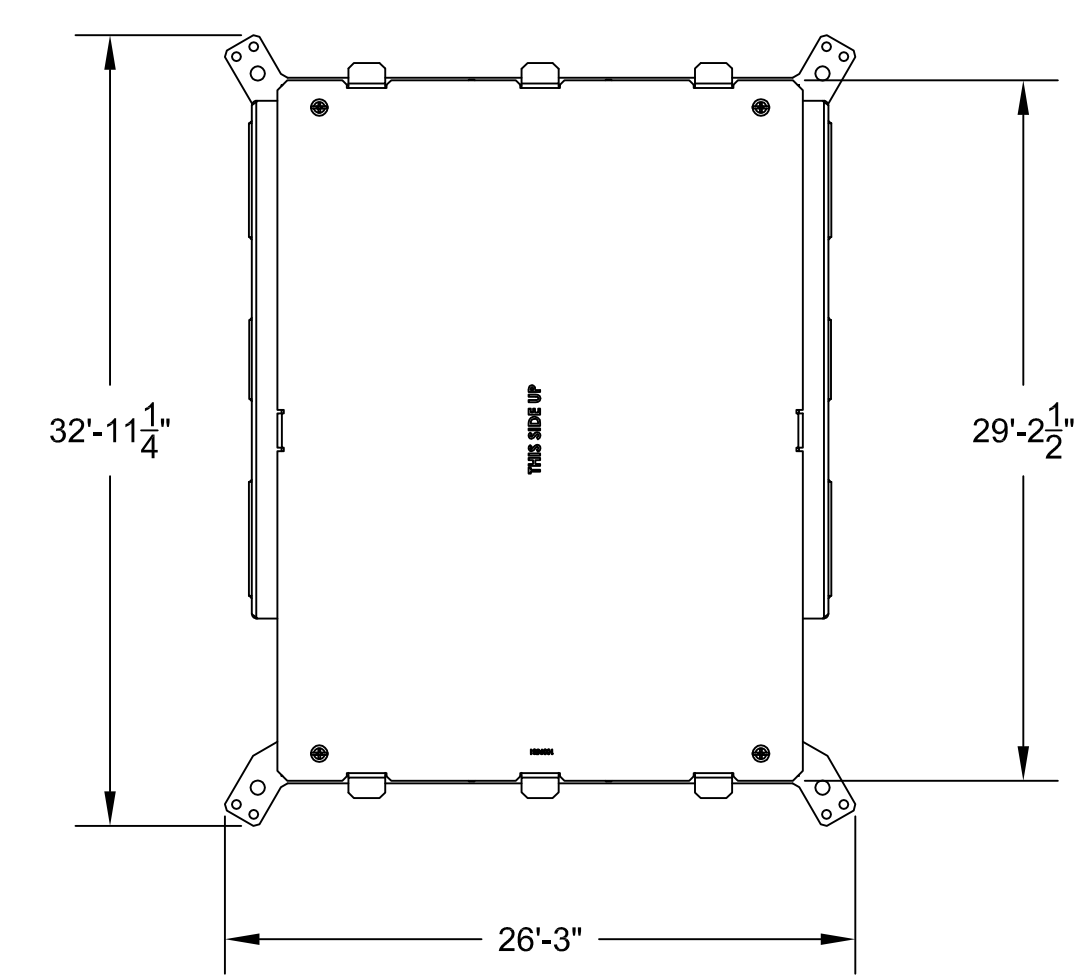
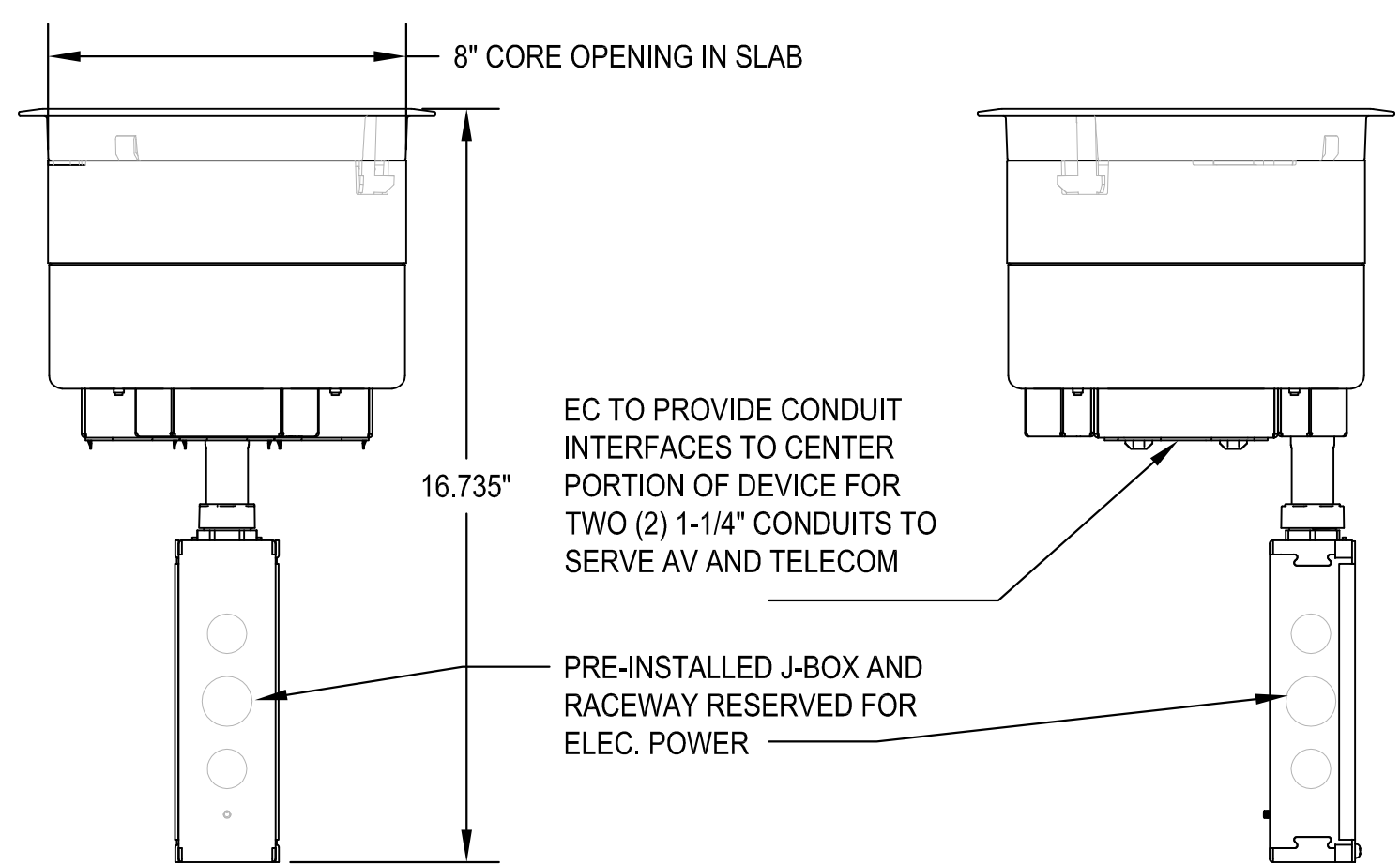
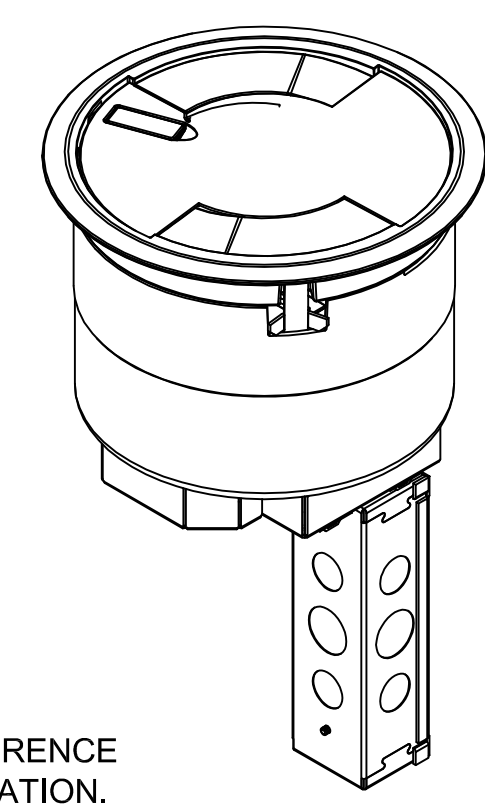

1 AUDIOVISUAL DETAIL - FLOOR BOX (TYP.)
SCALE: NTS

1 FLUSH FLOOR BOX DETAIL
NTS

NOTE: CONTRACTOR SHALL VERIFY ALL DIMENSIONS AND CONDITIONS AT JOB SITE AND BE FULLY RESPONSIBLE FOR SAME.

REVISIONS			DRAWN	PREPARED	100% CD FOR CONSTRUCTION				PROJECT NO.
NO.	DESCRIPTION	DATE	TL	RST	AUDIOVISUAL DETAILS				PROJECT NO.
01	REVISION A	09.16.14	TL	RST	<div style="display: flex; justify-content: space-between;"> <div style="text-align: center;"> DEMONICK A. DEMONICA ARCHITECTS 125 N. HALSTED STREET, SUITE 301 CHICAGO, IL 60661 P: 312.496.0000 </div> <div style="text-align: center;"> KJW ENGINEERING 1100 WARRENVILLE ROAD, #400W NAPERVILLE, IL 60563 T: 312.559.4585 </div> <div style="text-align: center;"> E.F. WHITNEY, INC. 568 ANN STREET BIRMINGHAM, MI 48009 T: 248.644.0990 </div> <div style="text-align: center;"> SHEN MILSOM WILKE LLC 2 N. RIVERSIDE PLAZA CHICAGO, IL 60606 T: 312.559.4585 </div> </div>				PROJECT NO.
02	REVISION B	09.16.14	TL	RST					DATE
03	REVISION C	10.29.14	TL	RST					APRIL 21, 2016
04	AV 100% DD FINAL REVISION	11.24.15	TL	RST					SHEET NO.
05	100% CD FOR CONSTRUCTION	03.25.16	TL	RST					TA802

NOTES:
 1) ELECTRICAL CONTRACTOR TO PROVIDE AND AND INSTALL ALL RACEWAY COMPONENTS.
 2) REFERENCE FURNITURE PLAN 2A9.01 FOR ANCHOR AND DRILLING PRECAUTIONS AND REQUIREMENTS

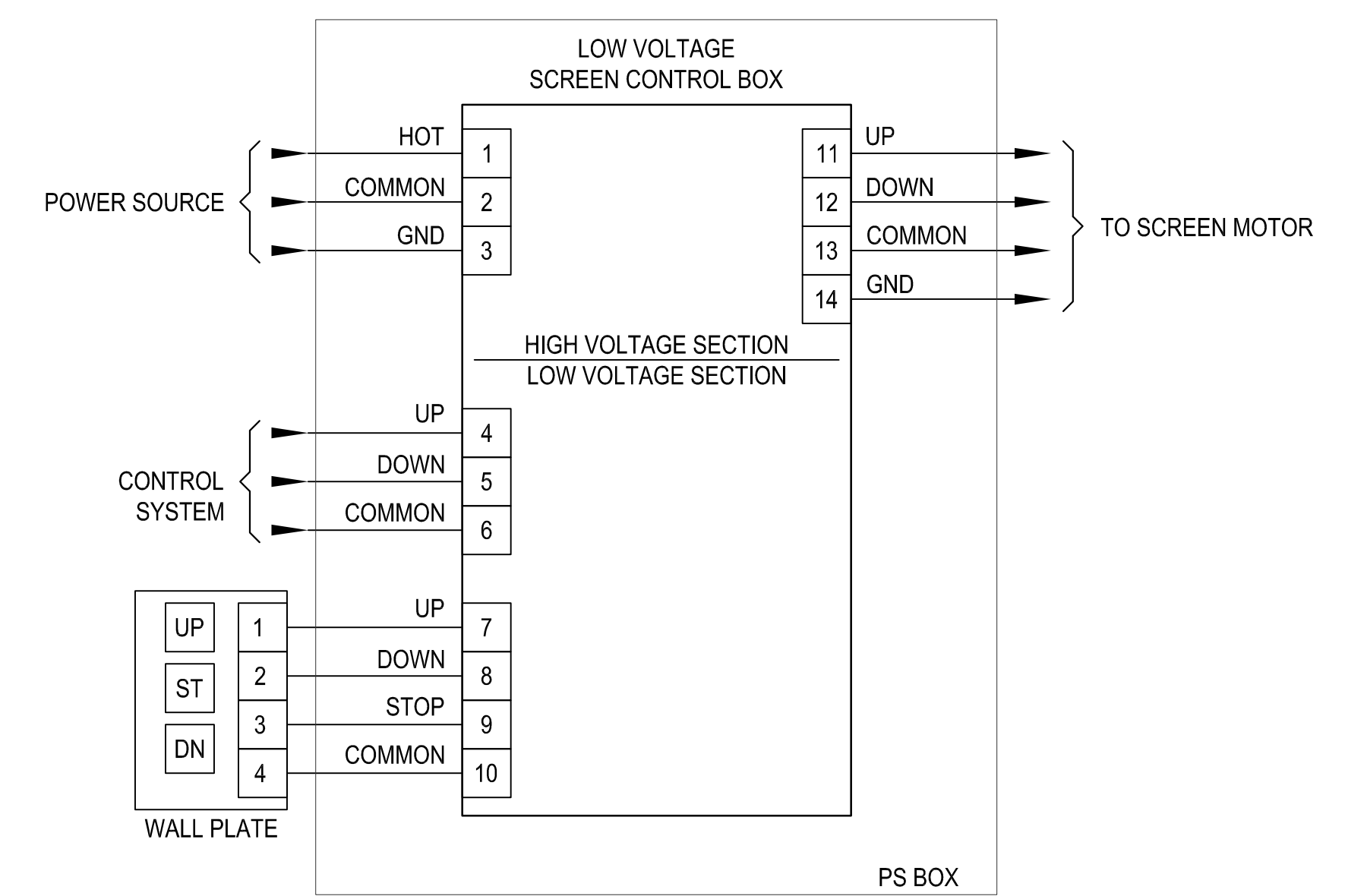
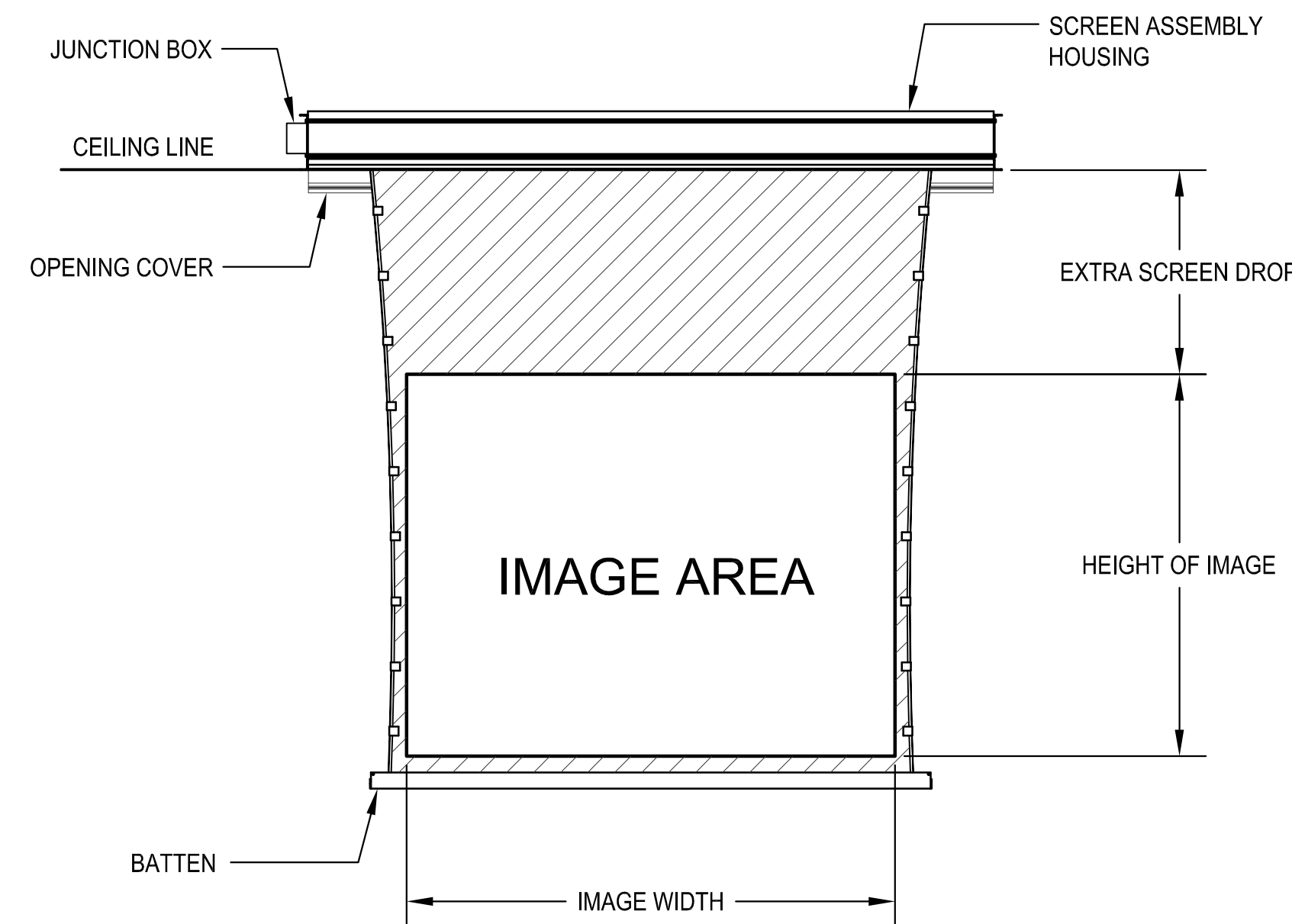

NOTE:
 LOW VOLTAGE AV INTERFACE CONTROL IS AN OPTION THAT MUST BE SPECIFIED WHEN ORDERING THE PROJECTION SCREEN.
 WIRING DETAILS WILL VARY AMONG MANUFACTURERS. REFER TO MANUFACTURER'S DOCUMENTATION FOR CONNECTION DETAILS.

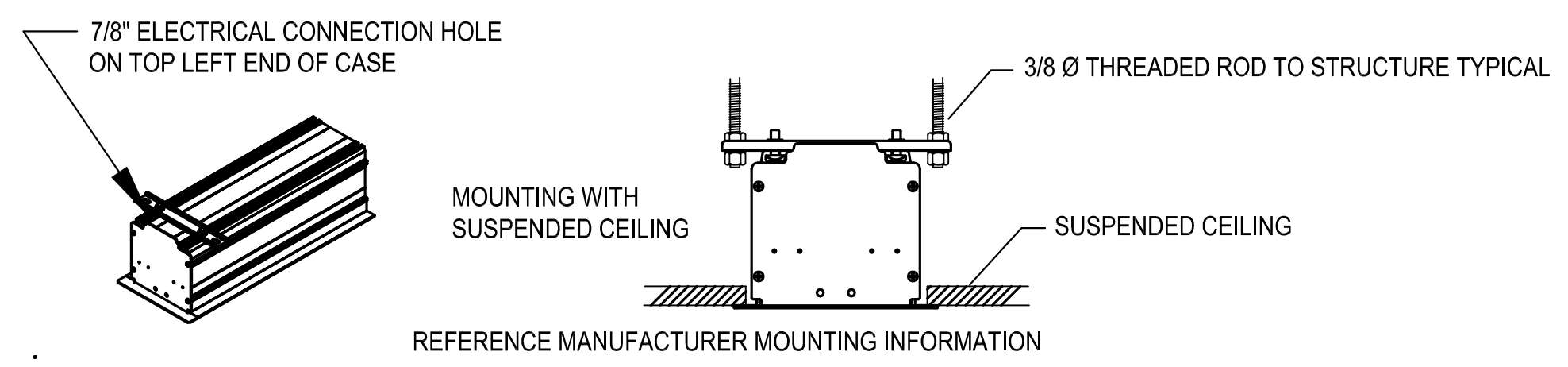

1 TAB TENSIONED FRONT PROJECTION SCREEN
 NTS

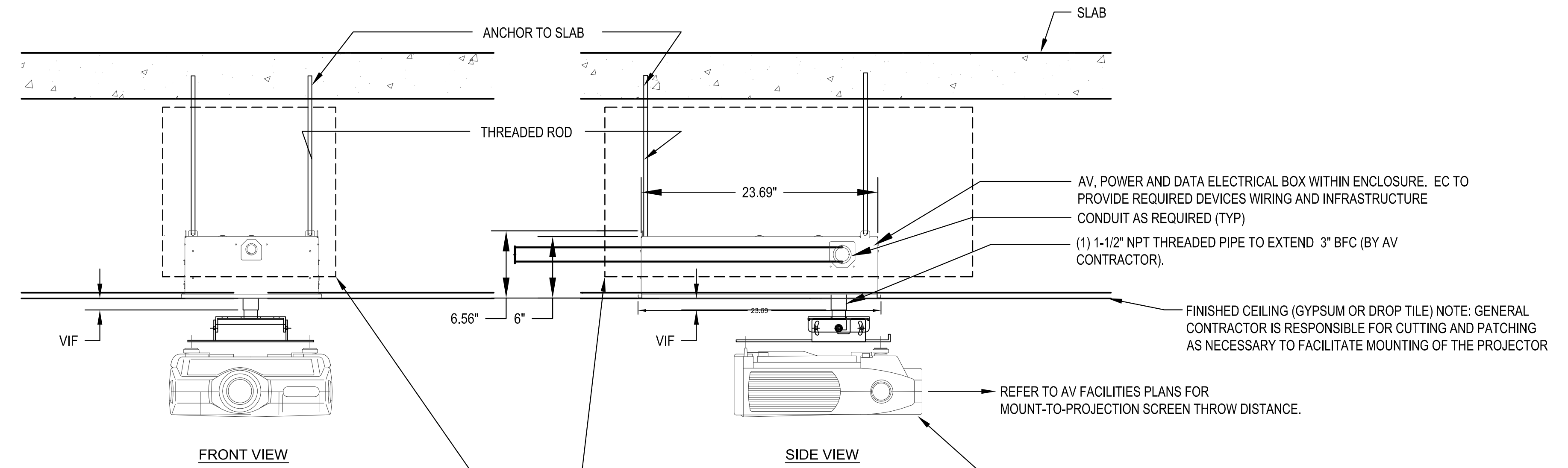

NOTES:
 1) ELECTRICAL CONTRACTOR TO PROVIDE AND AND INSTALL ALL RACEWAY COMPONENTS.
 2) AV CONTRACTOR RESPONSIBLE FOR PROJECTOR AND MOUNT TO ATTACH TO 1-1/2\"/>

1 VIDEO PROJECTOR MOUNTING
 NTS

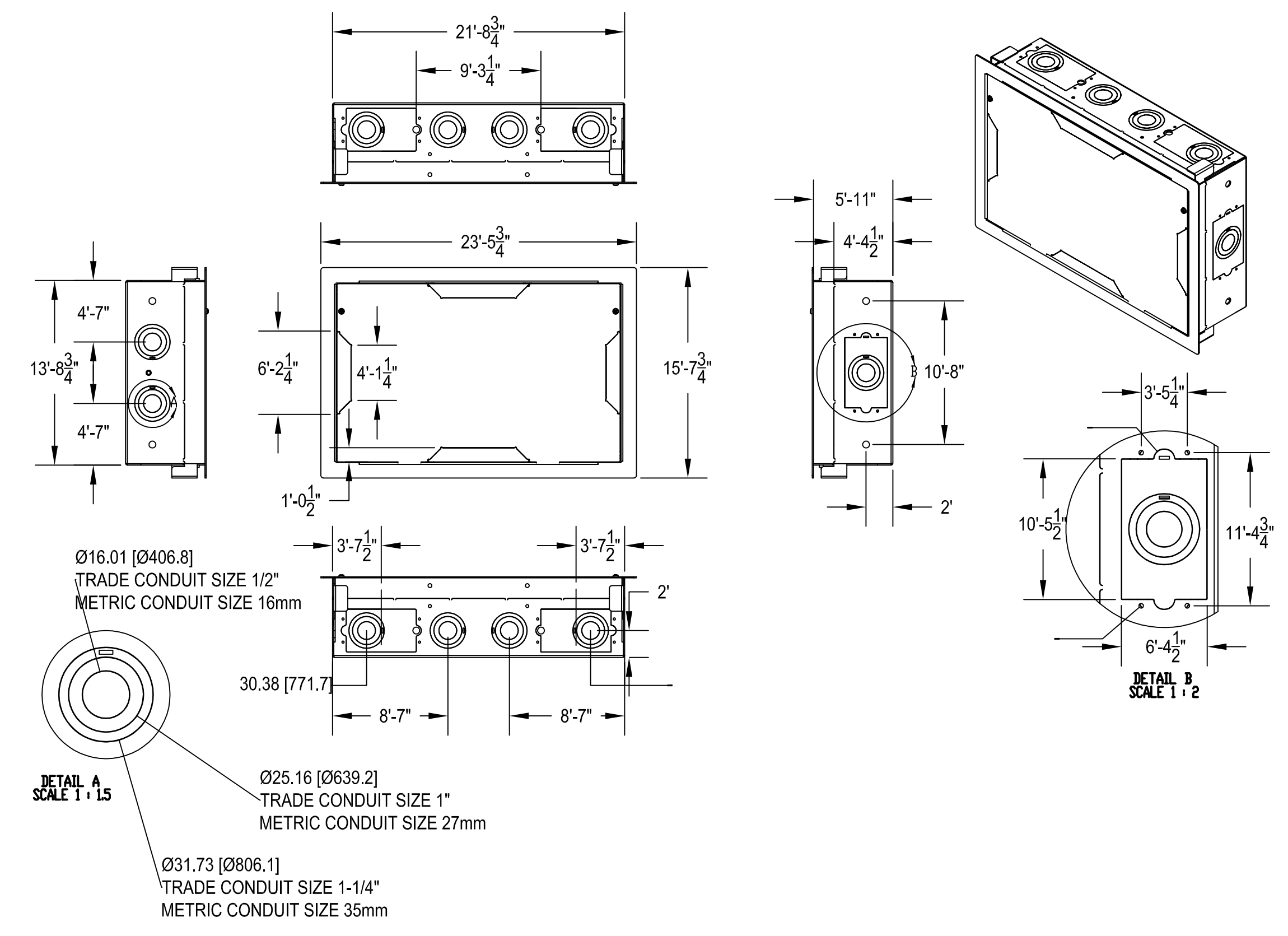

3 AUDIOVISUAL DETAIL - FLAT PANEL BACK BOX
 NTS

NOTE: CONTRACTOR SHALL VERIFY ALL DIMENSIONS AND CONDITIONS AT JOB SITE AND BE FULLY RESPONSIBLE FOR SAME.

REVISIONS <table border="1"> <tr><th>NO.</th><th>DESCRIPTION</th><th>DATE</th></tr> <tr><td>01</td><td>REVISION A</td><td>09.16.14</td></tr> <tr><td>02</td><td>REVISION B</td><td>09.16.14</td></tr> <tr><td>03</td><td>REVISION C</td><td>10.29.14</td></tr> <tr><td>04</td><td>AV 100% DD FINAL REVISION</td><td>11.24.15</td></tr> <tr><td>05</td><td>100% CD FOR CONSTRUCTION</td><td>03.25.16</td></tr> </table>		NO.	DESCRIPTION	DATE	01	REVISION A	09.16.14	02	REVISION B	09.16.14	03	REVISION C	10.29.14	04	AV 100% DD FINAL REVISION	11.24.15	05	100% CD FOR CONSTRUCTION	03.25.16	DRAWN: TL PREPARED: RST TRACED: TL APPROVED: RST CHECKED: TL APPROVED: RST	 DOMINICK A. DEMONICA 001-014360 SIGNED: _____ EXPIRES: _____	DEMONICA KEMPER ARCHITECTS 125 N. HALSTED STREET, SUITE 301 CHICAGO, IL 60661 P: 312.496.0000	KJWW ENGINEERING 1100 WARRENVILLE ROAD, #400W NAPERVILLE, IL 60563 T: 312.559.4585	E.F. WHITNEY, INC. 568 ANN STREET BIRMINGHAM, MI 48009 T: 248.644.0990	SHEN MILSOM WILKE 2 N. RIVERSIDE PLAZA CHICAGO, IL 60606 T: 312.559.4585	100% CD FOR CONSTRUCTION AUDIOVISUAL DETAILS CITY CENTER CAMPUS JOLIET JUNIOR COLLEGE	PROJECT NO. DATE: APRIL 21, 2016 SHEET NO. TA803
NO.	DESCRIPTION	DATE																									
01	REVISION A	09.16.14																									
02	REVISION B	09.16.14																									
03	REVISION C	10.29.14																									
04	AV 100% DD FINAL REVISION	11.24.15																									
05	100% CD FOR CONSTRUCTION	03.25.16																									

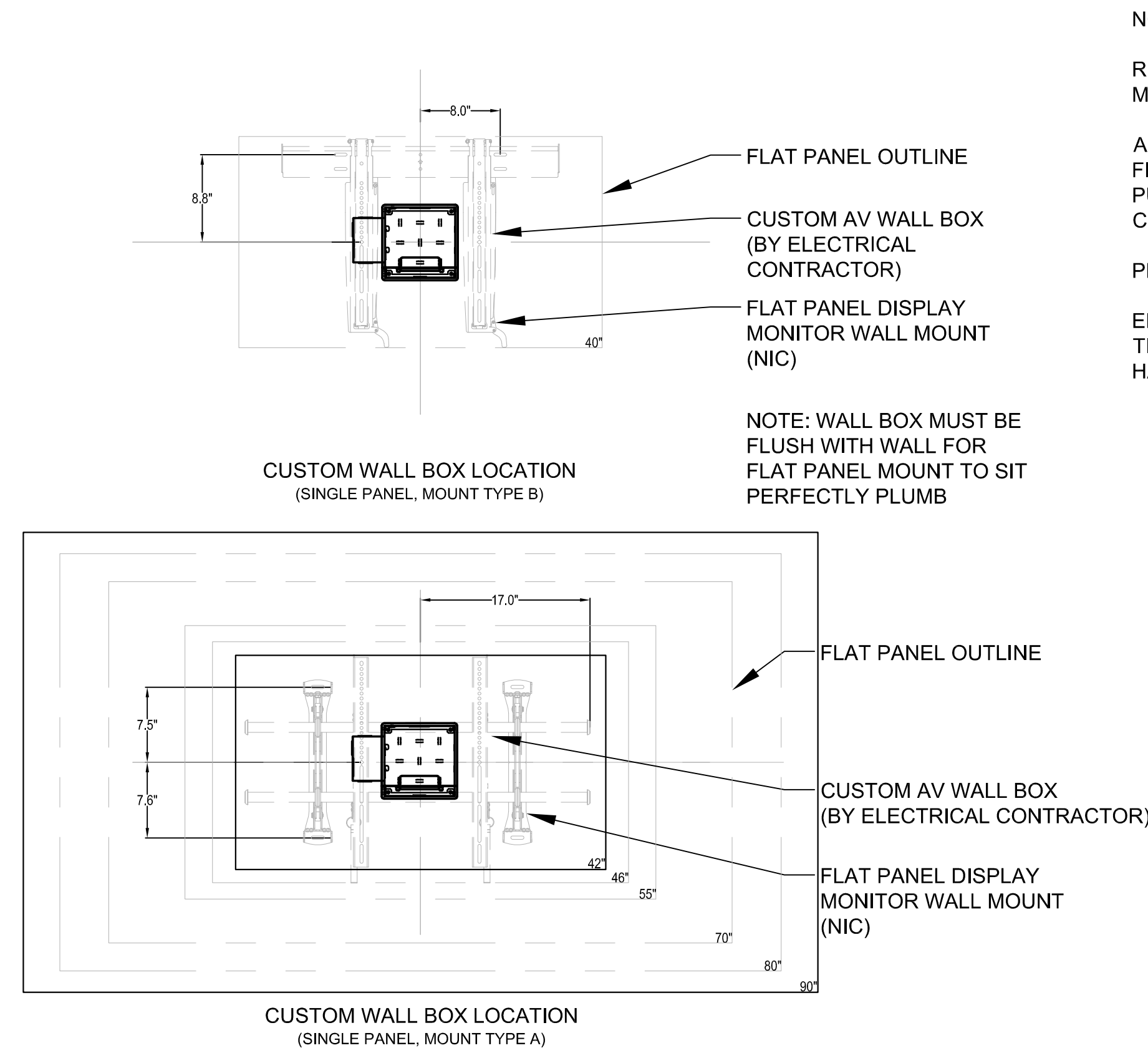

A CUSTOM WALL BOX LOCATION

NOTES:

REFER TO ARCH. DRAWING FOR EXACT LOCATIONS AND DETAIL OF FLAT PANEL DISPLAY MONITORS.

ARCHITECT TO PROVIDE NICHE FOR FLAT PANEL MONITOR TO LIMIT PROTRUSION FROM FINISHED WALL TO LESS THAN FOUR (4) INCHES AT ELEVATIONS LESS THAN 6'-8" A.F.F. IN PUBLIC CIRCULATION SPACE. ARCHITECT TO VERIFY ADA CODE REQUIREMENTS WITH CODE CONSULTANT.

PROVIDE SUPPORT BLOCKING FOR FLAT PANEL DISPLAY MONITOR.

ENSURE THAT THE STRUCTURAL MEMBERS CAN SUPPORT A REDUNDANT WEIGHT FACTOR FIVE TIME THE COMBINED TOTAL WEIGHT OF THE AUDIOVISUAL EQUIPMENT AND ALL ASSOCIATED HARDWARE AND COMPONENTS.

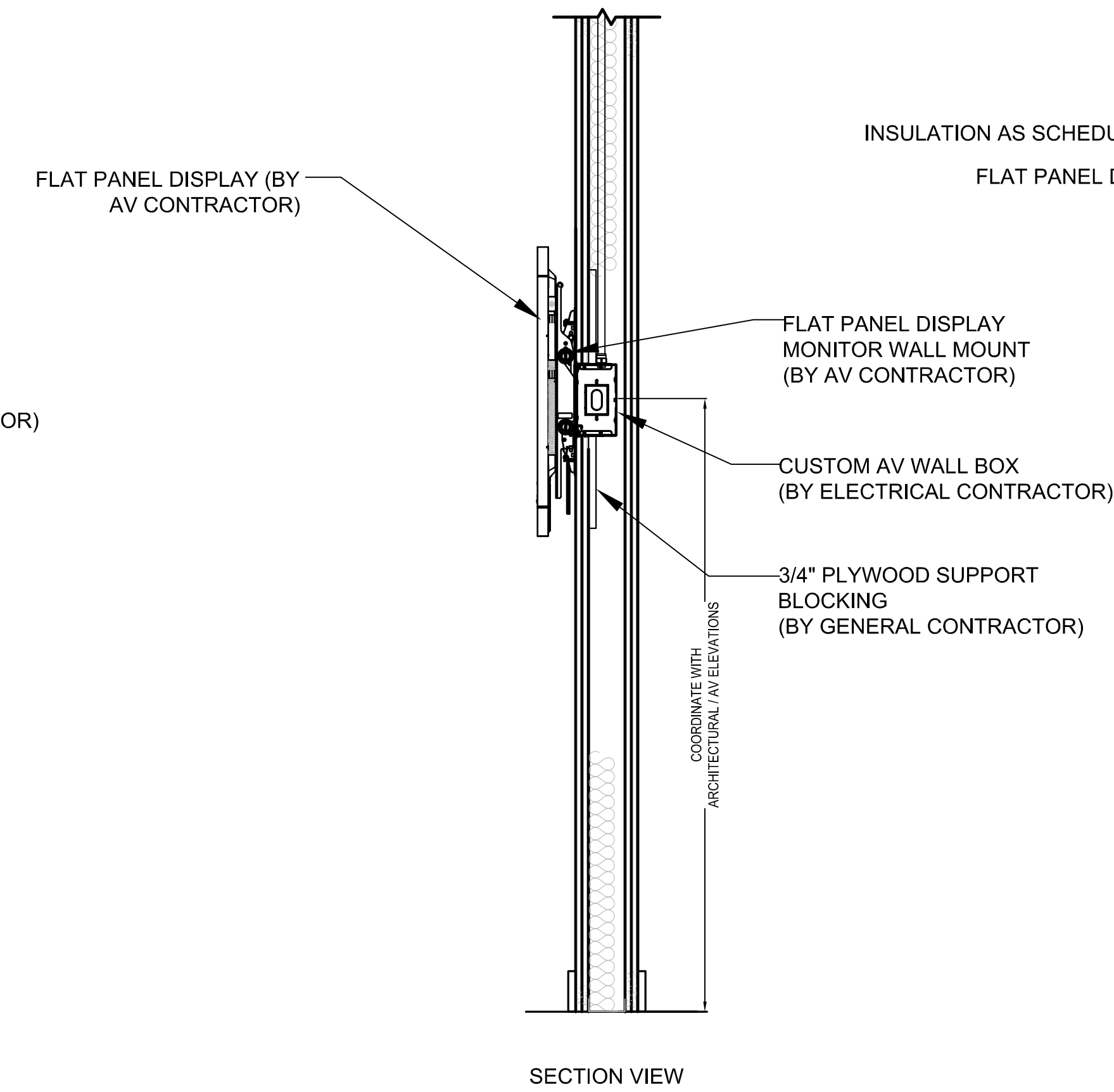

B FLAT PANEL MOUNTING DETAILS

2 FLAT PANEL MOUNTING DETAILS
SCALE: NTS

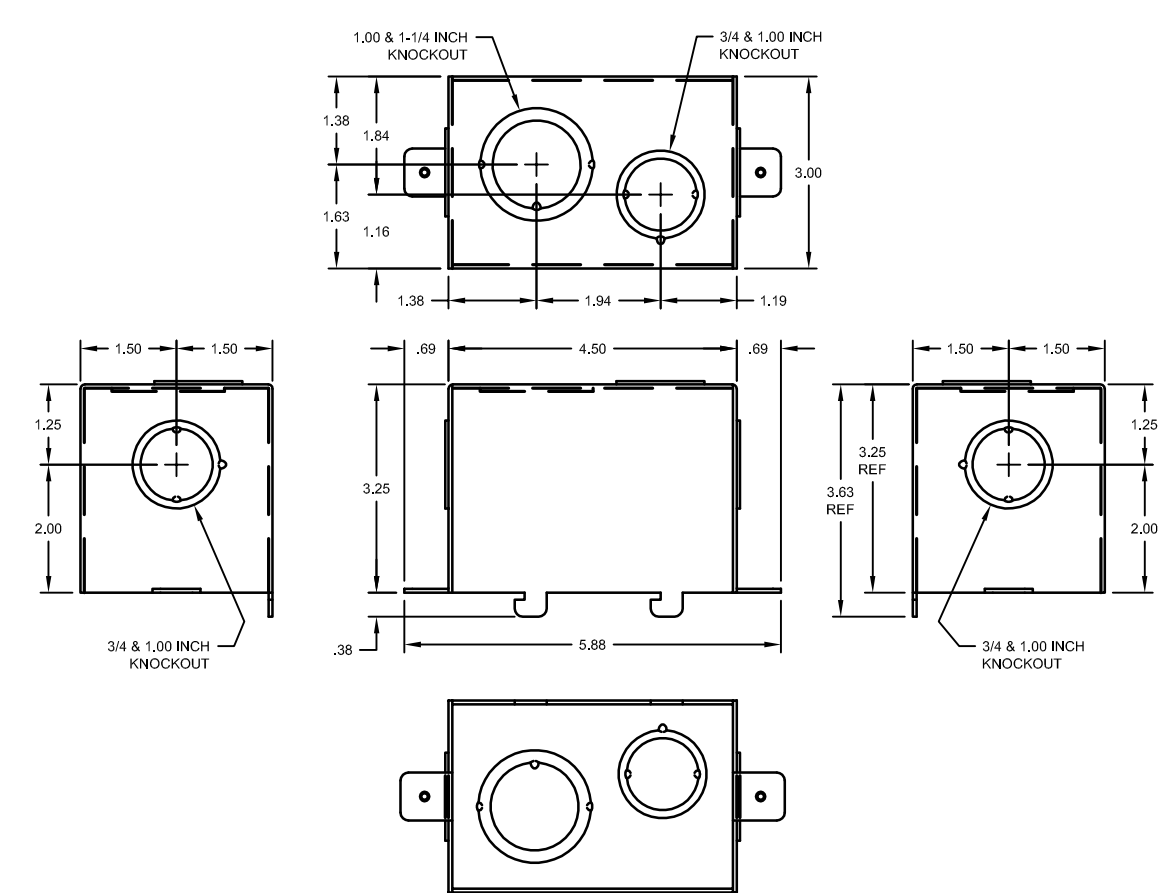

1 FLAT PANEL WALL BOX
SCALE: NTS

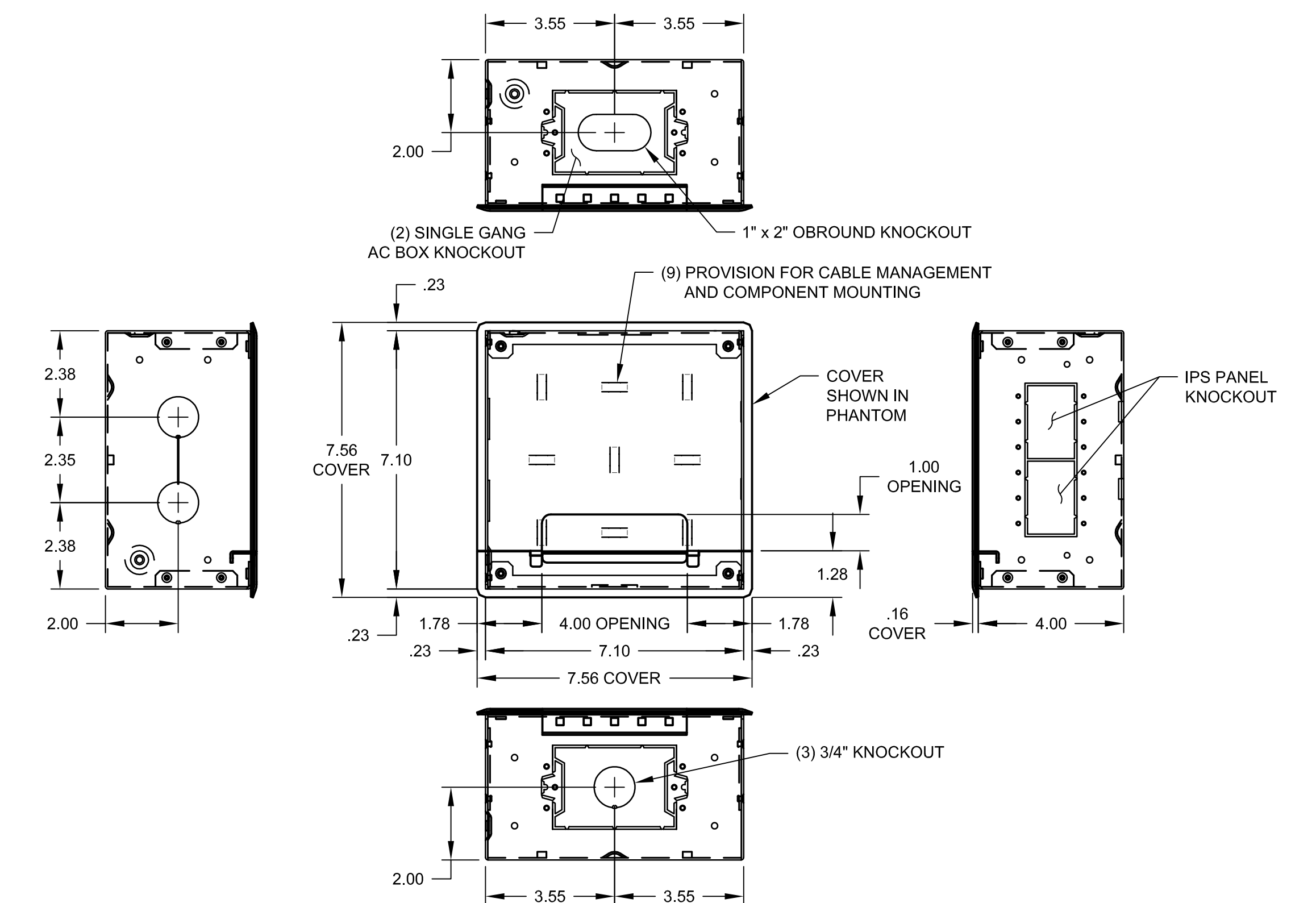
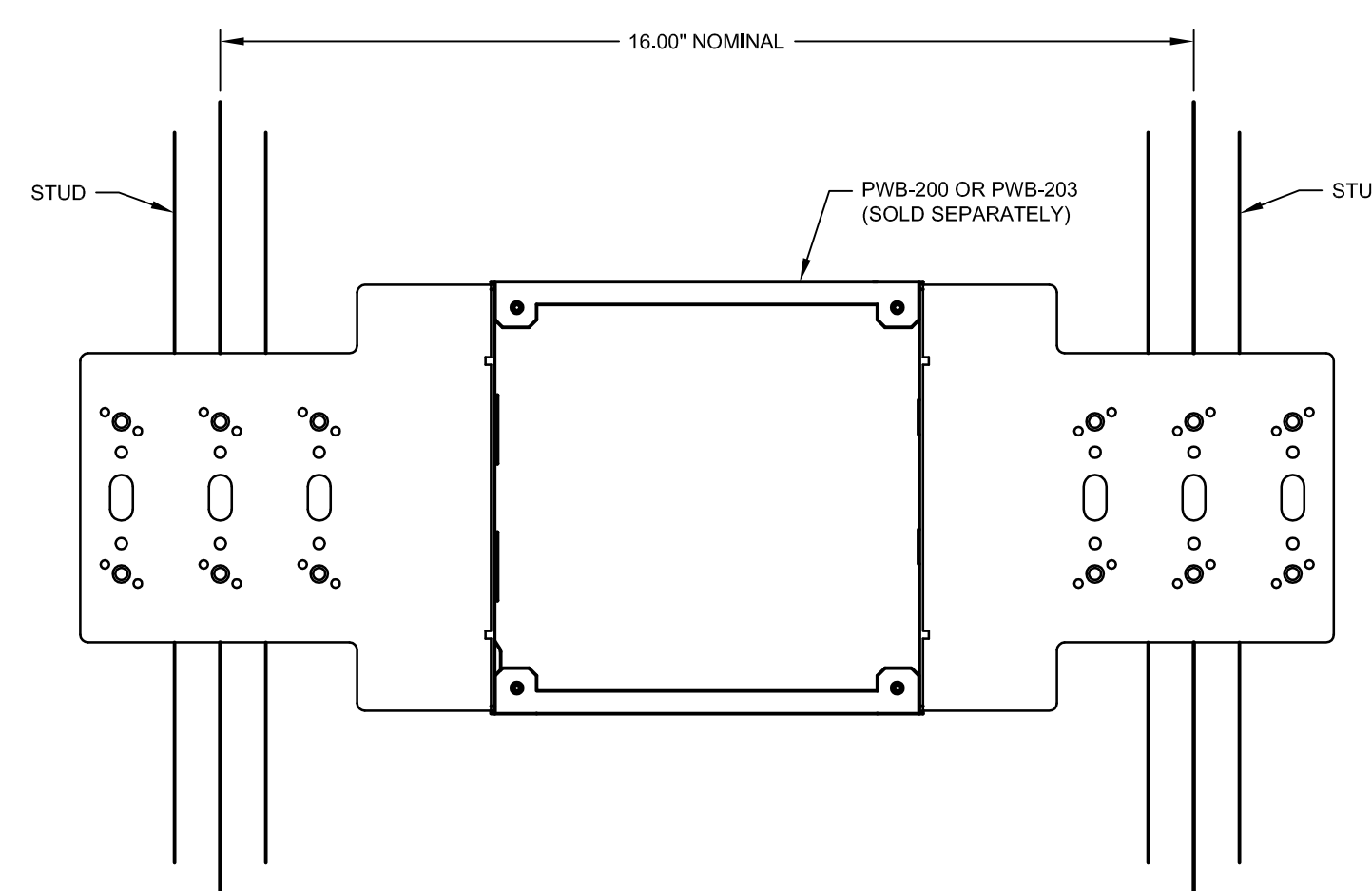

NOTE: CONTRACTOR SHALL VERIFY ALL DIMENSIONS AND CONDITIONS AT JOB SITE AND BE FULLY RESPONSIBLE FOR SAME.

REVISIONS			DRAWN	PREPARED	100% CD FOR CONSTRUCTION				AUDIOVISUAL DETAILS		PROJECT NO.
NO.	DESCRIPTION	DATE	TL	RST	STATE OF ILLINOIS DOMINICK A. DEMONICA 001-014360 SIGNED: EXPIRES:				CITY CENTER CAMPUS JOLIET JUNIOR COLLEGE		DATE
01	REVISION A	09.16.14	TL	RST	dka DEMONICA KEMPER ARCHITECTS 125 N. HALSTED STREET, SUITE 301 CHICAGO, IL 60661 P: 312.496.0000				SHEN MILSON WILKE 2 N. RIVERSIDE PLAZA CHICAGO, IL 60606 T: 312.559.4585		APRIL 21, 2016
02	REVISION B	09.16.14	TL	RST	KJW ENGINEERING 1100 WARRENVILLE ROAD, #400W NAPERVILLE, IL 60563 T: 312.559.4585				E.F. WHITNEY, INC. 568 ANN STREET BIRMINGHAM, MI 48009 T: 248.644.0990		SHEET NO.
03	REVISION C	10.29.14	TL	RST	SM&W SHEN MILSON WILKE				TA805		
04	AV 100% DD FINAL REVISION	11.24.15	TL	RST							
05	100% CD FOR CONSTRUCTION	03.25.16	TL	RST							